

製品型式 Indication of Model Numbers

DSF		14	P		C	100	MOTOR
シリーズ Type	サイズ Model		タイプ Style	入力形状 Input Style	減速比 Ratio		Motor Type
DSF DSG	14 17 20 25 32 40		P: Component Type A: Unit Type MC: Motor Flange Type S: Input Shaft Type	C: Input Collet K: Input Keyway ----- Style P, A は入力スタイルを選べる Input style is optional for style P, A.	1/50 1/80 1/100 1/120 ----- サイズ Model 14# 減速比 Ratio 1/50 1/80 1/100		

DSF □ -PC- □
DSG

PC

- コンポ-ネットタイプ - コレット入力
Component Type - Input Collet



DSF □ -AC- □
DSG

AC

- ユニットタイプ - コレット入力
Unit Type - Input Collet



DSF □ -MC- □
DSG

MC

- モータフランジタイプ
Motor Flange Type



DSF □ -PK- □
DSG

PK

- コンポ-ネットタイプ - コンポ-ネットタイプ
Component Type - Input Keyway



DSF □ -AK- □
DSG

AK

- ユニットタイプ - キー - 溝入力タイプ
Unit Type - Input Keyway



DSF □ -S- □
DSG

S

- 入力軸タイプ
Input Shaft Type



DSF / DSG 特性 Characteristic of DSF / DSG

規格 Model No.	単位 Unit	減速比 Ratio	14	17	20	25	32	40
定格出力トルク Nominal Output Torque	Nm	50	7	20	30	45	90	140
		80	9	27	40	72	138	209
		100	9	29	47	77	160	261
		120	-	29	47	77	160	298
平均負荷最大トルク Max. Output Torque	Nm	50	9	32	40	64	127	200
		80	13	33	55	99	195	288
		100	13	48	58	123	253	377
		120	-	48	58	123	253	457
起動停止ピーク値トルク Emergency Stop Starting Torque	Nm	50	21	42	66	112	225	350
		80	27	53	86	157	316	452
		100	32	67	96	180	346	494
		120	-	67	102	191	367	537
起動转矩 Starting Torque	cNm	50	4	6	8	15	32	55
		80	3	4	5	9	20	35
		100	2.5	3.5	4	8	18	32
		120	-	3	4	7	15	28
増速起動トルク Output Starting Torque	Nm	50	1.5	2.6	4.1	8.2	17	29
		80	1.6	2.7	4.2	8.4	18	30
		100	1.7	2.8	4.3	8.6	19	32
		120	-	2.9	4.5	8.8	20	34
無負荷ランニングトルク No-load Running Torque	cNm	50	4	5	7	12	28	48
		80	3	4	6	10	20	30
		100	2	3	5	8	18	26
		120	-	3	4	7	14	25
定格入力回転速度 Nominal Input Speed	rpm	50~120	2,000	2,000	2,000	2,000	2,000	2,000
最大入力回転速度 Max. Input Speed	rpm	50~120	6,000	6,000	5,000	5,000	5,000	4,000
慣性モーメント Reducer Inertia	lx10-4kgm ²	50~120	0.04	0.08	0.2	0.4	1.7	4.5
効率 Efficiency	%	50	70	73	73	73	75	75
		80	68	70	72	72	74	74
		100	64	66	70	70	72	72
		120	-	64	68	68	70	70
温度 Operating Temperature	℃	50~120	Environment -10℃ ~ +70℃ / Max. Working Temperature 90℃					
潤滑剤 Lubrication		50~120	Synthetic Grease No.2					
騒音レベル Noise Level	dB	50~120	52	54	56	58	60	62



MODEL : DSF-PC、DSG-PC

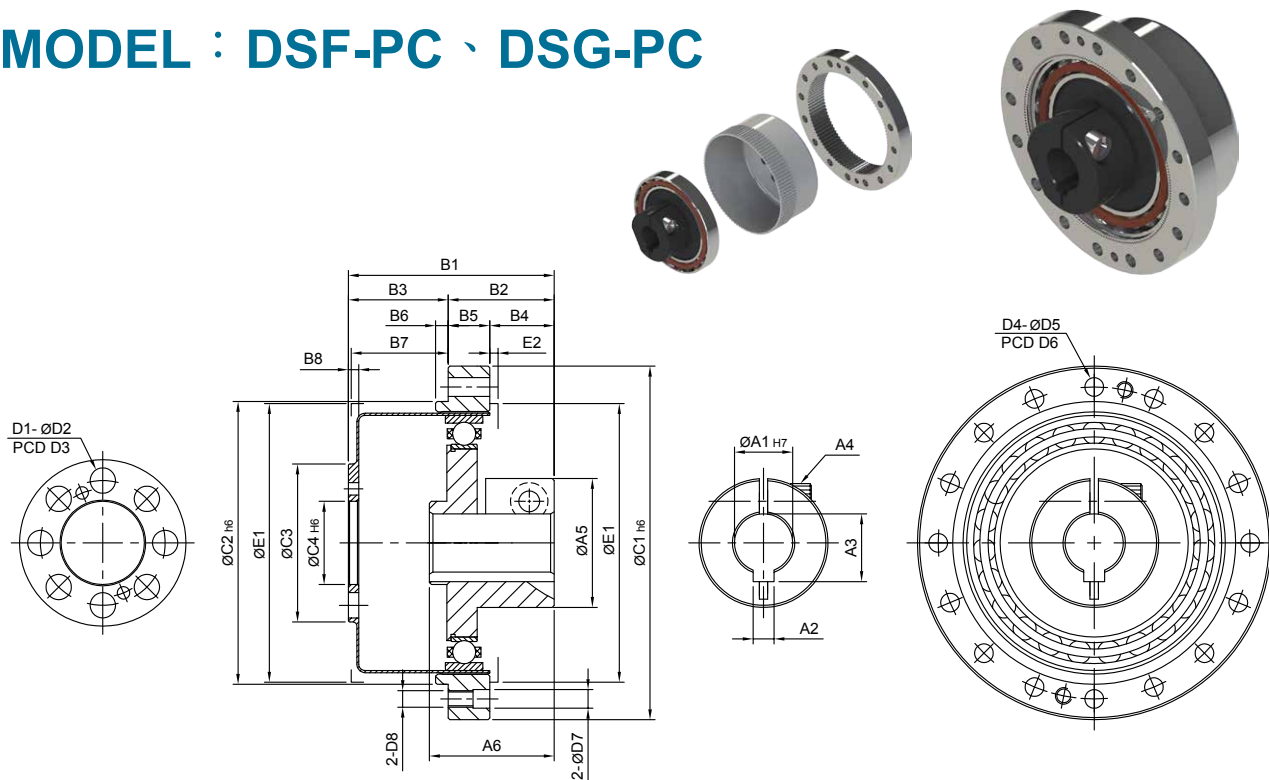

Code \ サイズ Model	14	17	20	25	32	40
A1	8	8	8、11、14	14	14、19	19
A2	3	3	3、4、5	5	5、6	6
A3	9.4	9.4	9.4、12.7、16.3	16.3	16.3、21.8	21.8
A4	M4xP0.7	M4xP0.7	M4xP0.7、M5xP0.8	M5xP0.8	M5xP0.8	M5xP0.8
A5	23.5	23.5	23.5、26、31	31	34、38	38
A6	22	23	25.5、27.5	30	32.5	36.5
B1	36	39	42.5、44.5	49.5	58	67.5
B2	18.5	19	21、23	25.5	30	33.5
B3	17.5	20	21.5	24	28	34
B4	12.5	12.5	13.5、15.5	15.5	16	16.5
B5	6	6.5	7.5	10	14	17
B6	2	2.5	3	3	3	4
B7	16.5	19	20.5	23	27	33
B8	2.4	3	3	3	3.2	4
C1	50	60	70	85	110	135
C2	38	48	54	68	90	110
C3	23	26	31	38	50	64
C4	11	10	14	20	26	32
D1	6	6	8	8	8	8
D2	4.1	5.1	5.1	6.1	8.1	10.1
D3	17	19	24	30	40	50
D4	DSG	8	16	16	16	16
	DSF	6	12	12	12	12
D5	3.5	3.4	3.5	4.5	5.5	6.6
D6	44	54	62	75	100	120
D7	-	-	3.5	4.5	5.5	6.6
D8	M3xP0.5	M3xP0.5	M3xP0.5	M4xP0.7	M5xP0.8	M6xP1.0
E1	37	46	53	67	86	105
E2	1.5	1.5	2	2	2	3
オーリング O-Ring	d35x1.0t	d44x1.2t	d51.82x1.5t	d63.22x1.78t	d84.5x2.0t	d107.62x2.62t
質量 Weight (g)	132	195	300	495	1,018	3,383