

## 製品型式 Indication of Model Numbers

DHG	17	A	C	100	L	MOTOR
シリーズ Type	サイズ Model	タイプ Style	入力形状 Input Style	減速比 Ratio	軸方向 Shaft Direction	Motor Type
DHG	14 17 20 25 32 40 45	A: Unit Type O: 中空軸タイプ Hollow Input Shaft S: Input Shaft Type	C: Input Collet K: Input Keyway O: Hollow Input Shaft  ----- Style A は入力スタイル を選べる Input style is optional for style A.	1/50 1/80 1/100 1/120  ----- Model 14# Ratio 1/50 1/80 1/100	L: 左軸 Left Shaft R: 右軸 Right Shaft  ----- Input Style O は Shaft Direction を選べる Shaft direction is optional for style type O.	

### DHG □ -AC- □

#### AC

- Unit Type - Input Collet



### DHG □ -O- □

#### O

- Hollow Input Shaft



### DHG □ -AK- □

#### AK

- Unit Type - Input Keyway



### DHG □ -S- □

#### S

- Input Shaft Type



### DHG □ -AO- □

#### AO

- Unit Type - Hollow Input Shaft



## DHG 特性 Characteristic of DHG

規格 Model No.	単位 Unit	減速比 Ratio	14	17	20	25	32	40	45
定格出力トルク Nominal Output Torque	Nm	50	7	20	30	45	90	140	180
		80	9	27	40	72	138	209	317
		100	9	29	47	77	160	261	358
		120	-	29	47	77	160	298	408
平均負荷最大トルク Max. Output Torque	Nm	50	9	32	40	64	127	200	270
		80	13	33	55	99	195	288	395
		100	13	48	58	123	253	377	507
		120	-	48	58	123	253	457	629
起動停止ピーク値トルク Emergency Stop Starting Torque	Nm	50	21	42	66	112	225	350	450
		80	27	53	86	157	316	452	633
		100	32	67	96	180	346	494	677
		120	-	67	102	191	367	537	738
起動转矩 Starting Torque	cNm	50	11	30	40	58	86	140	165
		80	10	28	36	56	80	130	150
		100	9	26	34	52	73	120	140
		120	-	24	30	48	68	110	125
増速起動トルク Output Starting Torque	Nm	50	2.5	3.5	4.5	8.5	18	32	43
		80	2.7	3.8	5	9	19	35	45
		100	2.8	4.2	5.5	9.5	21	37	48
		120	-	4.5	6	10	23	42	55
無負荷ランニングトルク No-load Running Torque	cNm	50	4	6	8	15	30	53	70
		80	3	4	5.5	10	22	38	50
		100	2.5	3.5	5	9	20	33	45
		120	-	3.2	4.5	8	16	30	40
定格入力回転速度 Nominal Input Speed	rpm	50~120	2000	2000	2000	2000	2000	2000	2000
最大入力回転速度 Max. Input Speed	rpm	50~120	6000	6000	5000	5000	5000	4000	4000
慣性モーメント Reducer Inertia	lx10-4kgm <sup>2</sup>	50~120	0.04	0.08	0.2	0.4	1.7	4.5	8.8
効率 Efficiency	%	50	70	73	73	73	75	75	75
		80	68	70	72	72	74	74	74
		100	64	66	70	70	72	72	72
		120	-	64	68	68	70	70	70
使用温度範囲 Operating Temperature	℃	50~120	Environment -10℃ ~ +70℃ / Max. Working Temperature 90℃						
潤滑剤 Lubrication		50~120	Synthetic Grease No.2						
騒音レベル Noise Level	dB	50~120	52	54	56	58	60	62	64



# MODEL : DHG-AK

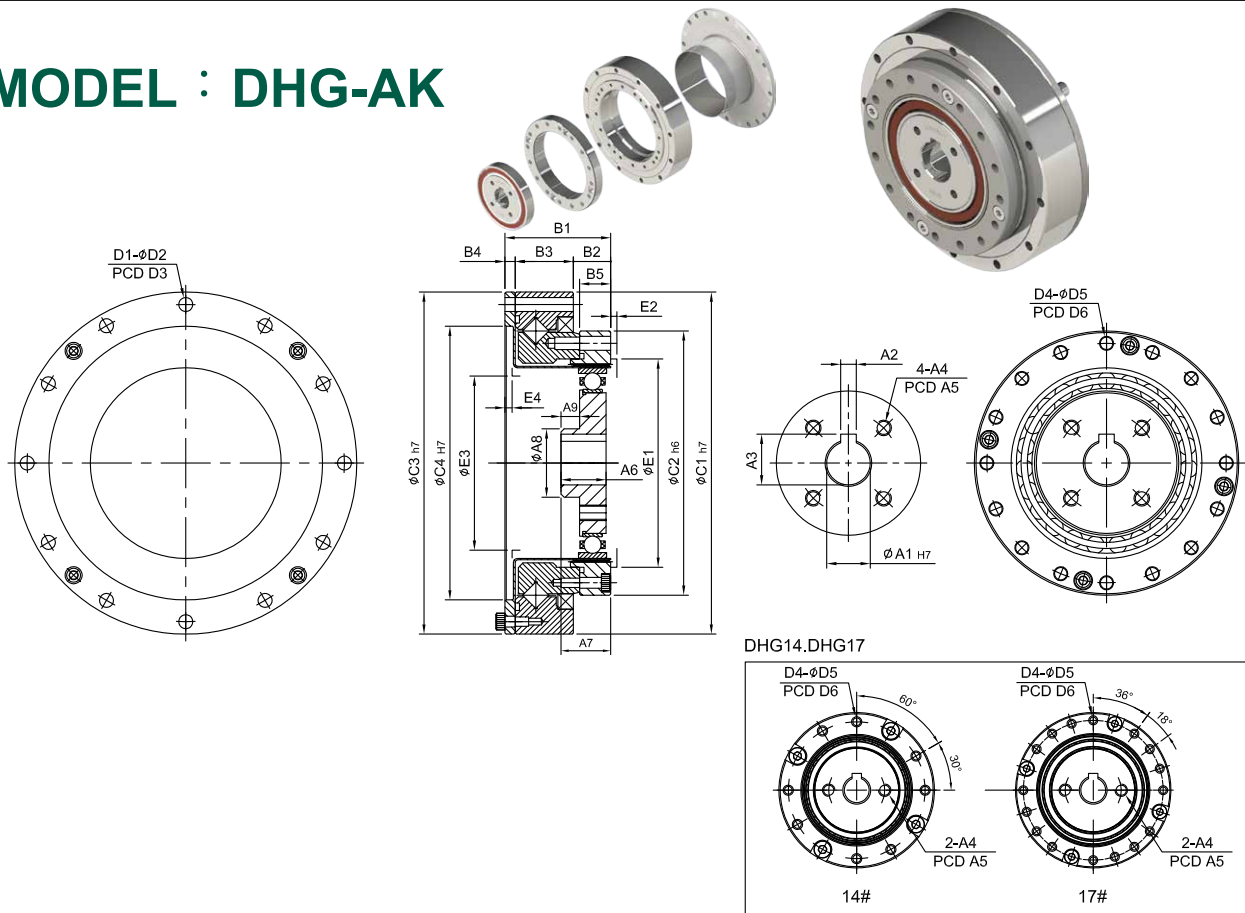

Code \ サイズ Model	14	17	20	25	32	40	45
A1	6, 8	8	8, 14	14	14, 19	19, 24	19, 24
A2	3, 3	3	3, 5	5	5, 6	6, 8	6, 8
A3	7, 9.4	9.4	9.4, 16.3	16.3	16.3, 21.8	21.8, 27.3	21.8, 27.3
A4	2-M4xP0.7	2-M4xP0.7	M4xP0.7	M5xP0.8	M5xP0.8	M5xP0.8	M6xP1.0
A5	18	22	25	32	36	50	50
A6	10	12.5	13.5	14.5	16	20	20
A7	10.5	13	14	16.3	17.45	23	22
A8	14	16	21	24	30	36	36
A9	2.3	4.2	4.3	6	5	7	5
B1	23.5	26.5	29	34	42	51	56.5
B2	7	7.5	8.5	12	15	18	20
B3	14.1	16	17.5	18.7	23.4	29	32
B4	2.4	3	3	3.3	3.6	4	4.5
B5	6	6.5	7.5	10	14	17	19
C1	70	80	90	110	142	170	190
C2	50	60	70	85	110	135	155
C3	70	80	90	110	142	170	190
C4	48	60	70	88	114	140	158
D1	8	12	12	12	12	12	18
D2	3.5	3.5	3.5	4.5	5.5	6.5	6.5
D3	64	74	84	102	132	158	180
D4	8	16	16	16	16	16	12
D5	3.3	3.5	3.5	4.5	5.5	6.5	8.5
D6	M3xP0.5x6L	M3xP0.5x6L	M3xP0.5x6L	M4xP0.7x8L	M5xP0.8x8L	M6xP1.0x10L	M8xP1.25x10L
E1	44	54	62	77	100	122	140
E2	38	46	54	67	86	106	119
E3	1.5	1.5	2	2	2	2	2
E4	30	36	44	56	72	92	105
E5	2	2	2	2	2	2.5	3
質量 Weight (g)	280	567	757	1,280	2,628	4,536	6,642