

WORM GEAR REDUCERS

蝸輪減速機



Worm Reducer Series

Features of Worm Reducer Series

蝸輪減速機系列產品特性

出力軸

中碳鋼 S45C，以 CNC 車床精密加工及研磨。

蝸輪

鋁青銅 ALBC3 & FC20，使用成形專用刀具切削及電腦輔助設計，摩擦係數小，使用壽命長。

出力軸蓋

鑄鐵 FC20 或 鑄鋁 AL，以 CNC 車床精密加工。

蝸輪箱

鑄鐵 FC20，本體一體鑄造，強度強，外型美觀散熱效果佳。

蝸桿

中碳鋼 S45C 或 SCM21 精密滾齒機切削，熱處理後經齒形研磨，故齒形正確，齒面平滑，運轉時效率高，無雜音。

右入力軸蓋

鑄鐵 FC20 或 鑄鋁 AL。

左入力軸蓋

鑄鐵 FC20 或 鑄鋁 AL。

Output Shaft

Medium carbon steel S45C, precision process and grinding with CNC lathe.

Worm Wheel

Aluminum brass ALBC3 & FC20, shaping cutter and computer auxiliary design low friction coefficient, durability in use.

Output Shaft Cover

Cast iron FC20 or cast aluminum AL, precision process with CNC.

Outer Shell

Cast iron FC20, one-line body, high intensity, elegant appearance, remarkable radiating effect.

Worm Shaft

Medium carbon steel S45C or SCM21, Cut by precision tooth-rolling machine; after being heated, grind the tooth so that the tooth is correct and smooth; high efficiency in operation; without noise.

Input Shaft Cover

Cast iron FC20 or cast aluminum AL.

Input Shaft Cover

Cast iron FC20 or cast aluminum AL.



Indication of Model Numbers

機種型號表示

HW	100	60	1	R
機型 Type	型號 Model	減速比 Ratio	馬力 Horse Power	軸向 Shaft Direction

機型

依外型傳動方式不同而區分：

一般而言，機型代號內

有 M 者為馬達直結式機種

有 O 者為出力軸中空機種

有 H 者為二段式蝸輪減速機 (蝸輪 + 蝸輪)

有 G 者為二段式蝸輪減速機 (齒輪 + 蝸輪)

型號

由入力軸中心至出力軸中心距離定

出，型號愈大體積愈大。

減速比

單段蝸輪減速機

一般速比：1/10 1/15 1/20 1/30 1/40 1/50 1/60

特殊速比：1/5 1/25 1/80

雙段蝸輪減速機

蝸輪 + 蝸輪：1/100.....1/3600

齒輪 + 蝸輪：1/80.....1/300

蝸輪減速機一般速比大部分為正減速比，但有部份機型非正減速比右表僅供參考，如需正確減速比請與我們連絡。

Most of the general ratio for worm gear reducer is same as actual ratio, but some models are different. The table on the right is for reference. Please contact us if you need actual ratio.

馬力

1/8HP~50HP 根據本目錄之馬力、型號選擇表。

軸向

R：右軸 (腳座貼地面，輸入端面向自己，此時輸出端位於右側)

L：左軸 (腳座貼地面，輸入端面向自己，此時輸出端位於左側)

V：單入力軸雙出力軸

W：雙入力軸單出力軸

WV：雙入力軸和雙出力軸

S：特殊軸 (訂貨時請註明或附圖面)

旋向：設計上蝸桿使用右旋牙，如需特殊旋向時請註明。

※TW、TMW 系列除外。

Type

Category by method of transmission

For the general reference：

M: type of motor upright joint

O: type of hollow output shaft

H: type of two-stage worm gear reducer (worm+worm)

G: type of two-stage worm gear reducer (gear+worm)

Model

The larger the model number (which is identified by the distance from the enter of input shaft to that of output shaft) is, the bigger the machine size is.

Ratio

1-Stage Reduction Worm Reducer

General Ratio：1/10 1/15 1/20 1/30 1/40 1/50 1/60

Special Ratio：1/5 1/25 1/80

2-Stage Reduction Worm Reducer

Worm-Worm：1/100.....1/3600

Gear-Worm：1/80.....1/300

型號 Model	速比 Ratio	實際減速比 Actual Ratio	型號 Model	速比 Ratio	實際減速比 Actual Ratio
30	15	1/14.5	250	40	1/41
	30	1/29		50	1/52
70	80	1/78		60	1/61
	100	1/94	300	10	1/10.25
175	50	1/51		15	1/14.33
				30	1/31
200	10	1/10.33		40	1/41
	30	1/31	60	1/63	
225	15	1/14.5	350	10	1/11
				20	1/22
				40	1/44
				50	1/49

以上型號包含所有機種。

Horse Power

1/8HP ~ 50HP

Shaft Direction

R: Right Shaft (when facing input shaft and foot on the ground, output shaft is on the right)

L: Left Shaft (when facing input shaft and foot on the ground, output shaft is on the left)

V: Single Input Shaft & Double Output Shaft

W: Double Input Shaft & Single Output Shaft

WV: Double Input Shaft & Single Output Shaft

S: Special shaft (Please specify your need clearly or attach drawing)

Rotary Direction: The worm shaft is right-hand thread. Please specify if you have special request.

※ Excluding TW and TMW series.

■ 減速機之選定 Selection of Worm Reducer

入力軸回轉數 & 出力軸回轉數

最高入力轉速盡量不要超過 2000RPM，一般使用約 600~1800RPM，轉速太高時容易使軸承及蝸輪、蝸桿因高度的磨擦而縮短壽命；轉速過低時可能導致潤滑不足或效率降低，如須使用特別高或低轉速時請註明。

出力軸回轉數 = 入力軸回轉數 ÷ 減速比
如特別低速回轉時，效率及扭力均會降低，並且使軸承給油較為困難。若須使用時須注意選擇機型及潤滑油。

$$\text{減速比} = \frac{\text{出力軸回轉數}}{\text{入力軸回轉數}} = \frac{60}{1800} = \frac{1}{30}$$

回轉方向 & 軸方向

蝸輪減速機之出力軸回轉方向取決於蝸桿旋牙方向，除特別情形外均使用右旋牙。當入力軸為順時針方向時出力軸為反時針方向，但二段式蝸輪減速機其入力軸與出力軸之回轉方向為同一方向。蝸輪減速機的軸向變化多，使用時請參考本目錄之"軸向選擇"。未註明時以右軸 (R) 為標準。

效率

由於減速機內部磨擦的損失，部份能量將轉為熱能消失。

依本目錄之附表所示

$$\text{效率} = \text{出力軸馬力} \div \text{入力軸馬力} \times 100\%$$

蝸輪減速機之效率取決於蝸輪之前進角、週速度、潤滑油、軸承的磨擦及材質的磨擦系數等。右表為效率之大約值，請參考。

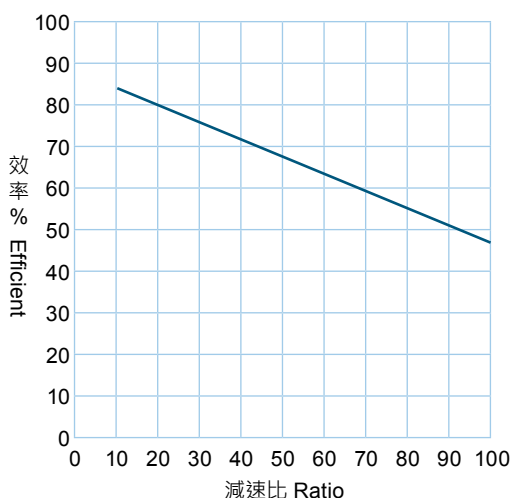

Revolutions of input shaft and output shaft

With belt-pulley or coupled shaft transmission, the highest input speed should not exceed 2000RPM; the general range is 600-1800RPM. If the revolving speed is too high, the earing will have less life due to over-friction; too low, the lubrication or efficiency will be reducer. Please specify either high or low speed.

output shaft revolution = input shaft revolution x reduction ratio
In case of any revolution of specially low speed, both the efficiency and torque will be lessened; further, it may be harder to provide oil on the bearing. Be careful to select the model number and lubricant oil.

$$\text{reduction ratio} = \frac{\text{output shaft revolution}}{\text{input shaft revolution}} = \frac{60}{1800} = \frac{1}{30}$$

Revolving direction and shaft direction

The revolving direction of output shaft relies on worm thread's direction; right-directed thread is for common use except for special conditions. When input shaft is in clockwise, output shaft is in counterclockwise; pay attention to two-stage worm reducer, the revolving direction of input and output shaft is the same. As a worm reducer has various shaft directions, be sure to see the user's manual titled "choice of shaft directions". For any not specified, refer the right shaft as the standard.

Efficiency

Due to the internal fabrication wear, partial energy will be transformed to be heat energy and fade away.

As the appendix shown in this catalog

$$\text{efficiency} = \text{output shaft HP} \div \text{input shaft HP} \times 100\%$$

The efficiency of the worm reducer depends on worm's advancing angle, periodical speed, lubricant oil, bearing friction and materials friction factor. For the approximated value of efficiency, please see the right table.

速比 Ratio	效率 % Efficient
1/10	82 ~ 85%
1/20	78 ~ 82%
1/30	73 ~ 76%
1/40	69 ~ 74%
1/50	67 ~ 72%
1/60	65 ~ 70%

馬力

馬力是一種動力的單位，由三個要素所組成。

1. 距離 (公尺 M 或公分 Cm)S
2. 重力 (公斤 Kg 或公克) P
3. 時間 (秒 Sec) $HP=(PxS)/75$

所謂 1 馬力就是在 1 秒的時間將 75Kg 的重物移動一公尺的距離，所以 1 馬力 =75Kg-M/Sec。

1 馬力之減速機可拖多大的力量？要知 1 馬力之馬達其所拖多大之力量時，必定要知道被拖動之機器的速度。1 馬力之馬達在每秒 1M 的速度下可拖動 75Kg 的力量，因馬達須經過減速機及其他傳動機構故實際傳到機器之馬力已不足 1HP，所以 1HP 之馬達在 1M 之速度下，所能拖動之力量，當在 75Kg 以下，其視機械效率而定。如為 1HP 之馬達在拖動每秒 2M 之速度的機器時，則可拖動 $75/2=37.5Kg$ 之力量，在每秒 1/2M 之速度時，則可拖動 $75 \div (1/2) = 150kg$ 之力量 (機械效率未計算在內) 其他各種場合可依此推算出。

每一型號之減速機皆有適合之馬力，請參考下表

使用系數

一般減速機之傳達容量及強度計算係依照每日八小時連續運轉與均一負荷的理想下設計因實際使用的情況不同在瞭解現場使用情況如：是否有反覆啟動、停止或正轉、逆轉、使用的時間、衝擊荷重等必須將使用係數計算在內，依適當的荷重係數來選擇適當的減速機型號，以免誤用過大或過小的減速機。

類別 Type	單段蝸輪減速機 1-Stage Reduction		雙段蝸輪減速機 2-Stage Reduction			
	10 ~ 30	40 ~ 60	蝸輪 - 蝸輪 Worm-Worm		齒輪 - 蝸輪 Gear-Worm	
Ratio Model			100 ~ 900	1000 ~ 3600	80 ~ 160	80 ~ 300
40	1/8	-	-	-	-	-
50	1/4	1/8	-	-	-	-
60	1/2	1/4	1/16	-	-	-
70	1	1/2	1/8	1/16	-	-
80	2	1	1/4	1/8	1	1/2
100	3	2	1/2	1/4	2	1
120	5	3	1	1/2	2	1
135	7 1/2	5	2	1	3	2
155	10	7 1/2	3	2	5	3
175	15	10	5	3	-	-
200	20	15	-	-	-	-
225	25	20	-	-	-	-
250	30	25	-	-	-	-
300	40	30	-	-	-	-
350	50	40	-	-	-	-

Horse Power

Horse power is the measuring unit of power, consisting of three elements:

- 1.distance (m or cm) S
- 2.gravity (kg or g) P
- 3.time (sec) $HP = (P \times S)/75$

1HP represents the distance where the load of 75kg in a second is moved,

so 1HP = 75Kg-M/Sec. How much power can a 1HP-reducer pull; which depends on the speed of the machine to be pulled. 1HP-motor is able to pull 75kg in a second 1M. As the motor should pass through the reducer and other transmission mechanism, 1HP is not enough. So the power 1HP motor can pull should be under 75Kg per the speed of 1M, depending on the mechanical efficiency. When 1HP motor pulls the machine with the speed of 2M per second, the pulling power is $75/2=37.5Kg$; with the speed of 1/2M per second, the pulling power is $75 \div (1/2) = 150Kg$ (the mechanical efficiency is not taken into account). For other events, this formula is applicable. Each reducer should adopt suitable HP, please see the table below.

Coefficient

For general reducers, the transmitted capacity and intensity are calculated per a continual operation of 8 hour a day and per the ideal conditions of a unified load design. However, for on-site use, it should take such factors into account as: repetitive start-up, stop or obverse, reverse rotation, use time, impact load and the like. Select an appropriate reducer model according to the load coefficient lest improper event should occur.

原動機 Prime Mover	傳動機負荷等級 Driven Machine Load lassification	每日使用時間 Duration Of Service Per Day			
		0.50 hrs	2 hrs	8 -10 hrs	10-24 hrs
電動機 Electric Motor	均一負荷 Uniform	0.80	0.90	1.00	1.25
	中衝擊 Medium Shock	0.90	1.00	1.25	1.50
	重衝擊 Heavy Shock	1.00	1.25	1.50	1.75

★正轉、逆轉或啟動、停止，一小時內達 10 次以上者，請將左表的值乘以 1.2。

For any obverse rotation / reverse rotation or start-up / stop to happen more than 10 times in one hour, multiply the values (listed in the left table) by 1.2.

減速機之選定 Selection of Worm Reducer

懸掛荷重

懸掛荷重為減速機出力軸，軸端所承受的力量。容許懸掛荷重並非表示減速機不可拖動多大的力量，而只是減速機之使用情況之選擇的依據。

各型減速機在各種使用場合下，皆有一定之容許轉矩， $T=F \times R$ 即轉矩 = 力量 x 力量施力線到旋轉中心之垂直距離。

式中之 F 與容許懸掛荷重有直接之關係，出力軸裝置鏈輪時， F 之最大容許值，即為容許懸掛荷重，如在出力軸裝置齒輪，則 F 之最大容許值為容許懸掛荷重的 0.8 倍，或容許懸掛荷重除以 1.25 倍（此 1.25 之數值即為懸掛荷重係數）當一減速機出力軸所裝之鏈輪或齒輪所受的拉力已計算出（鏈輪之容許拉力值，即為容許懸掛荷重，而齒輪之最大容許拉力值，即為容許懸掛荷重的 80%）依 $T=F \times R \quad R \leq T/F$ R 為鏈輪或齒輪之節圓半徑， T 為容許出力轉矩 F 為容許懸掛荷重。總之，當一減速機在使用時其出力之承受轉矩與懸掛荷重，一定在容許值以下，為其中之一大於容許值時，則須重新設計傳動機構或將減速機之型號改大。當承受轉矩超過容許轉矩時，減速機會發生過熱或蝸輪齒面過度磨損或軸扭斷之現象。當承受荷重超過懸掛荷重時，出力軸在使用過一段時間後會折斷。

懸掛荷重 (O.H.L.) 系數

Over-Hanging Load (O.H.L.) Coefficient

出力軸 Output Shaft	系數 F Coefficient
鍊輪傳動 Chain Pulley Transmission	1.00
齒輪傳動 Gear Transmission	1.25
V 皮帶輪傳動 V-Belt Transmission	1.50
平皮帶輪傳動 Flat Belt Transmission	2.50

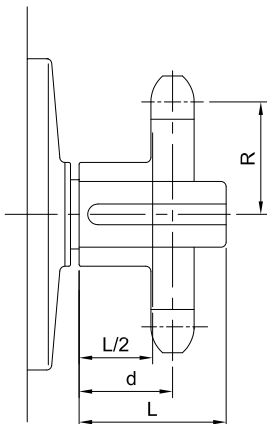

Over-Hanging Load (O.H.L)

O.H.L. stands for the force accepted from the output shaft end of the speed reducer. The allowed O.H.L. is not the dragging limit which the speed reducer can manage; it is only the optional reference which may be based for reducer use. Every type of reducers has a rotating allowed torque under different circumstances. $T=F \times R$ (i.e. torque = force x the perpendicular distance from force application line to rotating center). In this formula, F is directly related to the allowed O.H.L.; if the output shaft connects with the chain pulley, the maximum allowed F -value is the allowed O.H.L.; if the output shaft connects with gear, the maximum allowed F -value = O.H.L. x 0.8 (or O.H.L. ÷ 1.25; the coefficient of O.H.L. is 1.25). The pulling force accepted from the chain pulley or gear which is attached to the output shaft of the reducer is calculated (the allowed pulling force equals to 80% of the allowed O.H.L.) by $T = F \times R \quad R < T/F$ (R stands for pitch radius of the chain pulley or gear; T stands for the allowed output torque; F stands for the allowed O.H.L.). To sum up, when the reducer is in operation, its output load torque and O.H.L. have to be limited below the allowed value; when either output load torque or O.H.L. is above the allowed value, it needs to re-design the transmission mechanism or to change larger model number of the reducer. When the load torque exceeds the allowed value, either the reducer will be over-heated or the worm gear be over worn out or the shaft be broken.

$$OHL = \frac{T' \times f \times l}{R}$$

T' = 補正後之扭力 (Corrective torque)

f = OHL 系數 (O.H.L. Coefficient)

l = 位置系數 (Position factor)

R = 皮帶輪或鍊輪半徑

(Radius of belt-pulley or chain pulley)

(1). $d \leq L/2$

當負載在軸的中點或中點以內

(When Load is at middle or inner side)

位置系數 (Position factor) $S=1$

(2). $d > L/2$

當負載在軸的中點以外

(When Load is at outer side)

位置系數 (Position factor) $S=2$

減速機之選定計算範例 Criteria for Reducer Selection

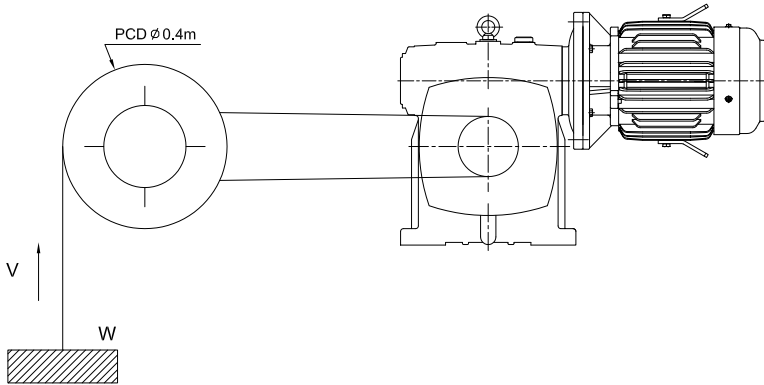

- ◆ 搬運物總重量 Total Weight of Cargo: $W=800\text{kg}$
- ◆ 搬送速度 Carrying Speed: $V=15\text{m/min}$
- ◆ 鍊輪傳動效率 Chain Pulley Transmission Coefficient: $\eta_1=0.97$
- ◆ 減速機傳動效率 Reducer Transmission Coefficient: $\eta_2=0.75$
- ◆ 運轉時間 Operation Time: 8 小時 / 日 8 hours / day
- ◆ 啟動次數 Start Frequency: 1 回 / 分, 中衝擊 1 time/min., medium shock
- ◆ 使用電源 Power: 三相 220V, 60Hz 3 phase 220V, 60Hz

減速比 Ratio	選定之注意事項 Notices Calculation Example	計算範例 Load Condition Notices Calculation Example
	<p>藉由必要之入力軸回轉數及出力軸回轉數來選定減速比</p> <ol style="list-style-type: none"> 1. 先求出輸送帶滾輪回轉數 (N1) $N1 = \text{搬送速度} / (\text{滾輪直徑} \times \pi)$ 2. 總減速比 = 滾筒回轉數 / 入力軸 (馬達) 回轉數 (R1) 3. 總減速比 = 減速機減速比 x 鍊輪減速比 (R2) 選定鍊輪減速比 $R2=1/5$ 4. 減速機之減速比 $R1=1/30$ <p>Reduction Ratio Notices Calculation Example The reduction ratio is based on input / output shaft revolutions.</p> <ol style="list-style-type: none"> 1. Find the revolution of conveyer pulley (N1) first $N1 = \text{carrying speed} / (\text{pulley } D \times \pi)$ 2. Total reduction ratio = pulley revolutions / input shaft (motor) revolutions revolutions (R1) 3. Total reduction ratio = reduction ratio of reducer x reduction ratio of chain pulley Reduction ratio of selected chain pulley: $R2 = 1/5$ 4. Reduction ratio of reducer: $R1=1/30$ 	<ol style="list-style-type: none"> 1. $N1 = V / (D \times \pi)$ $= 15 / (0.4 \times 3.14) = 12 \text{ r/min (PRM)}$ 2. $R = 12 / 1800 (\text{馬達轉數 Motor RPM})$ $= 1 / 150$ 3. $R = R_1 \times R_2$ $1/20 \times 1/7.5$ $1/30 \times 1/5$ $1/40 \times 1/3.75$ $1/50 \times 1/3$ $1/60 \times 1/2.5$ 4. $N2 = 1800 \times 1/30 = 60$
扭力 Torque	<p>減速機所要的出力扭力 (搬運物重量 x 滾輪半徑 x 鍊輪減速比) / (鍊輪效率 x 減速機效率)</p> <p>The output torque needed by reducer (load x pulley x radius x reduction ratio of chain pulley) / (chain pulley efficiency x reducer efficiency)</p>	<p>計算範例</p> <p>Load Condition Notices Calculation Example</p> $T1 = W \times (D/2) \times R2 / (\eta_1 \times \eta_2)$ $= [800 \times (0.4 / 2) \times (1/5)] / (0.97 \times 0.75)$ $= 43.98$
負荷條件 Load conditions	<p>根據運轉條件算出補正扭力 8 小時運轉、中衝擊、係數 1.25(K)。</p> <p>Load Condition Notices Calculation Example Find corrective Torque according to operation condition 8 hrs operation, medium Impact, coefficient 1.25 (K).</p>	<p>計算範例</p> <p>Load Condition Notices Calculation Example</p> $T2 = (\text{補正扭力 Corrective Torque}) T1 \times \text{運轉條件 (係數 K)}$ $\text{Operation Condition (coefficient K)}$ $= 43.98 \times 1.25 = 54.98 \text{ kgf}\cdot\text{m}$
馬力 Horse Power	<p>最後換算成馬力 (HP) $HP = (\text{補正扭力} \times \text{出力軸轉數}) / 716.2$</p> <p>Find Horsepower (HP) $HP = (\text{Corrective Torque} \times \text{Output RPM}) / 716.2$</p>	<p>計算範例</p> <p>Load Condition Notices Calculation Example</p> $HP = (T2 \times N2) / 716.2$ $= (54.98 \times 60) / 716.2 = 4.6 \text{ HP}$ <p>5HP 馬達適用 (For 5HP motor)</p>
型號選定 Model Selected	<p>根據本目錄之馬力型號選擇表 5HP、減速比 1/30、型號 120 適用。 According to the selection table of HP & model, model 120, 5HP, reduction ratio 1/30 are selected.</p>	

減速機安裝 Usage and Installation

使用前請檢查

- ◆ 檢查機種、型號、馬力、軸方向、減速比回轉方向及入力軸出力軸回轉數是否符合。
- ◆ 注意檢查注油情況，先確定是否有油，並保持油量在油面計一半以上。

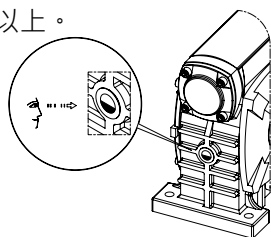

場所

- ◆ 須裝置於平且堅固的底部。
- ◆ 安裝之環境須乾燥且通風良好，周圍溫度 0°C ~40°C 異常高溫或低溫時請註明。
- ◆ 使用前請拔掉加油蓋上的插梢。

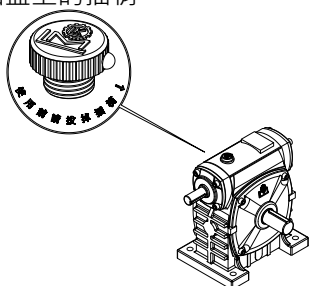

連結方式

- ◆ 當聯接器用以聯入力或出力軸時，須確實固定並務使兩軸平行，底座須以適當螺栓，確保固鎖緊密。
- ◆ 所有配備均應輕裝於軸上，勿使用鐵鎚，並避免裝配過緊而引起軸承損壞。
- ◆ 滑輪、鏈輪或齒輪在裝配時應盡量靠近軸承以減少彎曲應力。使用適當大小（在出力軸徑的 6 倍以內）與出力軸連接之鍊輪、皮帶輪等請配合 H7 公差使用，可避免發出異聲與軸面受損。
- ◆ 各型加馬達盤之入力孔可加添適當黃油，避免孔徑過度磨損及發出異聲。
- ◆ 軸面可塗上防鏽塗料避免生鏽。

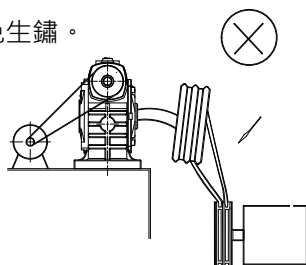

Check Before Operating

- ◆ Check if the type, model No., horsepower, shaft direction, reduction ratio, revolution direction and input/output shaft revolutions are in accordance with the standard.
- ◆ Check carefully the oil level to make sure that the oil volume is sufficient and maintain above the middle of oil gauge.

Place

- ◆ A flat and solid base is one of the requirements for installation.
- ◆ The environment for installation shall be dry and well ventilated, with ambient temperature at 0°C to 40°C . Abnormal high or low temperature shall be dedicated.
- ◆ Please pull the pin out of the plug lid before use.

Connecting Method

- ◆ If coupler is used to connect input or output shaft, make sure they are firmly fixed and paralleled. The base seat shall be anchored with proper bolts.
- ◆ All of the components shall be properly assembled to the shaft. Avoid hammering and over-tight assembly which could damage the bearing.
- ◆ The pulley, chain pulley and gear shall be assembled as close to the bearing as possible to minimize the curving stress. The chain pulley and belt pulley used to connect the output shaft shall be properly chosen (within 6 times as large as the diameter of output shaft) and used in accordance with H7 tolerance so as to keep out of abnormal noise and harm to the shaft surface.
- ◆ Proper amount of grease can be applied to the input hole of the additional motor board to ensure the hole against over-wearing and making abnormal noise.
- ◆ The application of anti-rust paint can keep the shaft from rusting.

■ 潤滑油之選定 Selection of Lubricant Oil

適當潤滑油的黏度，須使蝸輪與蝸桿磨擦容易，遇高負荷及衝擊負荷時，減速機才能充分發揮其機能。下表即 "利明牌" 減速機潤滑油的選定：

Proper viscosity of lubricant is contributive to ease the friction of worm gears, so the speed reducer can fully apply its function in the case of high load or impact load. The table below shows the selection of lubricants for LIMING speed reducers:

荷重 (Load)	中國石油國光牌極壓機油 CPC E.P. LUBRICANT					SHELL OIL	MOBIL OIL	ISO VG
	Grade No.	黏度 (Cst) Viscosity		流動點 Pour Point	閃火點 Flash Point			
		40°C	100°C					
普通荷重 Common Load	HD-150	143.6	14.38	- 18°C	264°C	OMALA OIL 150	MOBIL GEAR 629	ISO VG EP 150
	HD-220	212.2	18.59	- 18°C	278°C	OMALA OIL 220	MOBIL GEAR 630	ISO VG EP 220
	HD-320	310.5	23.7	- 18°C	290°C	OMALA OIL 320	MOBIL GEAR 632	ISO VG EP 320
超荷重 Heavy Load	HD-220	212.2	18.59	- 18°C	278°C	OMALA OIL 220	MOBIL GEAR 630	ISO VG EP 220
	HD-320	310.5	23.7	- 18°C	290°C	OMALA OIL 320	MOBIL GEAR 632	ISO VG EP 320
	HD-460	440.4	29.8	- 18°C	310°C	OMALA OIL 460	MOBIL GEAR 634	ISO VG EP 460

注意事項

- ◆ 本公司出廠減速機，使用 ISO VG 150 的極壓機油。
- ◆ 最初使用 300 小時後，洗淨內部、換上新油以後每 2500 小時換油。
- ◆ 在高速、高溫、低速、重荷重、強制潤滑等特殊情況下使用場合，請與本公司洽商。
- ◆ 潤滑油不足可能導致蝸輪快速磨損和效率降低。
- ◆ 潤滑油過多可能導致漏油。
- ◆ 請加入適當潤滑油至油量計一半以上 (請參考油量表)。

Notice

- ◆ LI MING speed reducers use ISO VG 150 lubricant oil.
- ◆ After initial 300 hours of use, clean the internal part and replace with new lubricant; then, do it every 2500 hours.
- ◆ If use in the special conditions of high speed, high temperature, low speed, heavy load, and forced lubrication, please contact the company.
- ◆ Insufficient lubricant oil may lead to the rapid wears of worm gear and low efficiency.
- ◆ Excessive lubricant could result in leakage.
- ◆ Please feed proper lubricant above half of the oil meter (see oil gauge).

WORM REDUCER SERIES

蝸輪減速機系列

■ 安裝方向 Installation Direction

● 油面計
Oil Indicator

▼ 注油栓
Oil Plug

△ 排油栓
Oil Drain Plug

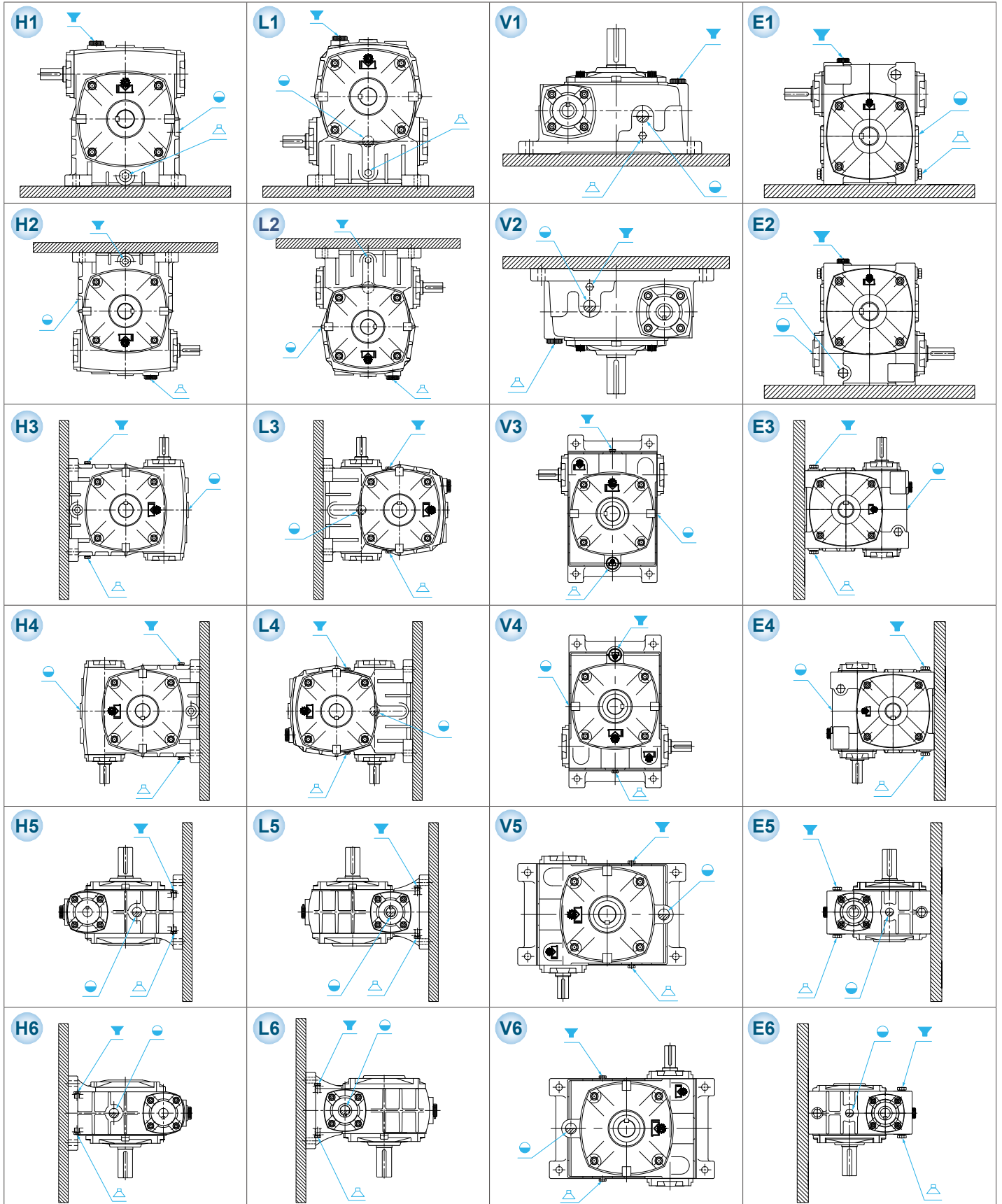

W 系列 Series

HW :

入力軸在出力軸上方，可方便且容易地安裝鍊輪、皮帶輪等，但型號較大時，潤滑油供給較困難，型號從 40# 至 175#。

The input shaft which is above the output shaft can provide convenient and easy installation of chain pulley and belt pulley, etc. For the larger model No., it is not easy to feed lubricant. Model No.: 40# to 175#.

HMW(MW) :

同 HW，附加馬達盤及入力孔，可直接連接 IEC 尺寸之馬達，安裝快速、容易，型號從 50# 至 175#。

Same as HW above. With additional motor flange and input bore, this model can be directly connected to IEC motor. The installation is fast and easy. Model NO.: 50# to 175#.

LW :

入力軸在出力軸下方，使入力軸浸在油中，潤滑效果最好，適合較高扭矩傳動，型號從 50# 至 350#。

The input shaft which is below the output shaft is submerged in the oil so as to provide good lubrication effect. Suitable for higher torque transmission. Model NO.: 50# to 350#.

分解系統圖 System Drawing

MODEL : HW

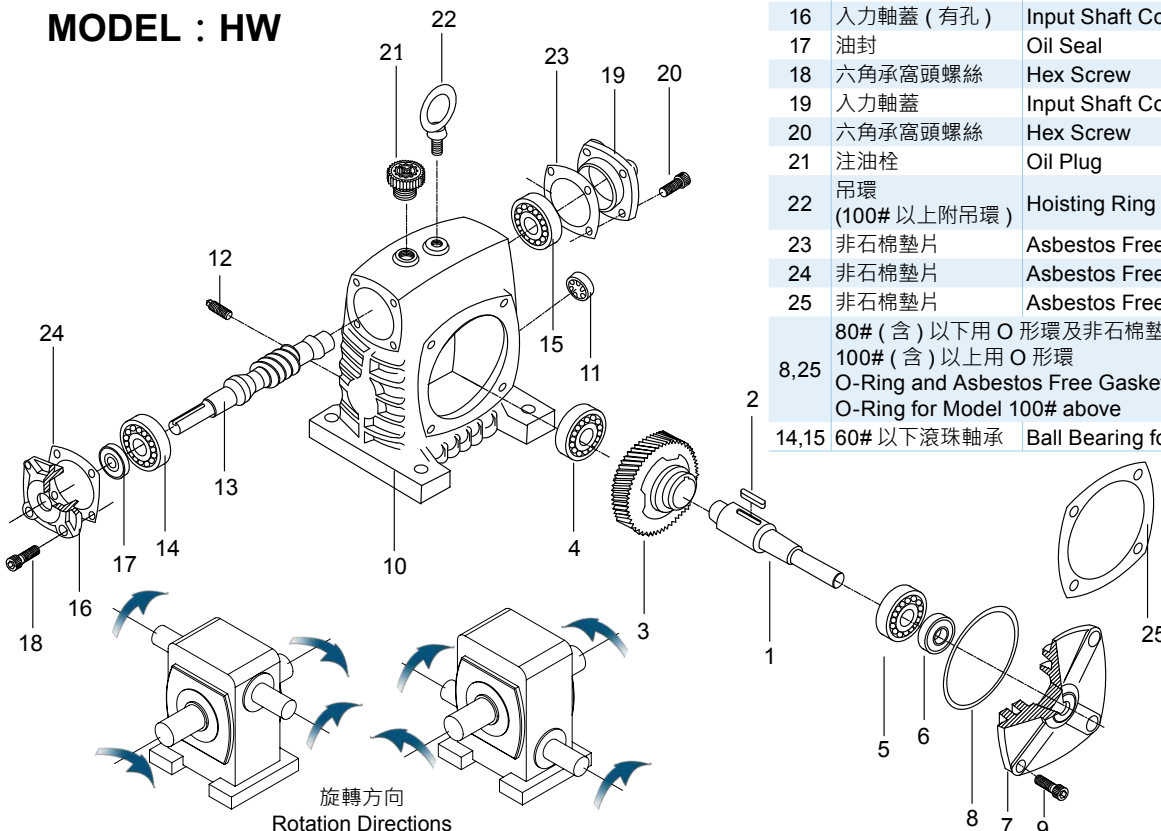

油量表 Oil Capacities (unit: ℓ)

Type Model	HW	LW	MW	HOM	HOW	LOW	WRC
40	0.2	-	-	-	-	-	-
50	0.4	0.2	0.4	0.4	0.4	0.2	0.4
60	0.5	0.3	0.5	0.5	0.5	0.3	0.5
70	0.8	0.5	0.8	0.8	0.8	0.5	0.8
80	1.2	0.6	1.2	1.2	1.2	0.6	1.2
100	2.6	1.2	2.6	2.6	2.6	1.2	2.6
120	4.5	2.1	4.5	4.5	4.5	2.1	4.5
135	7	3.4	7	7	7	3.4	-
155	11	4.5	11	10	10	4	-
175	12.5	6.4	12.5	11.5	11.5	6	-
200	-	7	-	-	-	-	-
225	-	6	-	-	-	-	-
250	-	7.6	-	-	-	-	-
300	-	9.2	-	-	-	-	-
350	-	12.6	-	-	-	-	-

NO.	零件名稱	Name of Parts
1	出力軸	Output Shaft
2	雙圓鍵	Key
3	蝸輪	Worm Wheel
4	滾珠軸承	Ball Bearing
5	滾珠軸承	Ball Bearing
6	油封	Oil Seal
7	出力軸蓋	Output Shaft Cover
8	O 形環	O-Ring
9	六角承窩頭螺絲	Hex Screw
10	蝸輪箱	Outer Shell
11	油鏡	Oil Gauge
12	排油栓	Oil Drain Plug
13	蝸桿	Worm Shaft
14	滾錐軸承	Taper Roller Bearing
15	滾錐軸承	Taper Roller Bearing
16	入力軸蓋 (有孔)	Input Shaft Cover (with bore)
17	油封	Oil Seal
18	六角承窩頭螺絲	Hex Screw
19	入力軸蓋	Input Shaft Cover
20	六角承窩頭螺絲	Hex Screw
21	注油栓	Oil Plug
22	吊環 (100# 以上附吊環)	Hoisting Ring for 100# above
23	非石棉墊片	Asbestos Free Gasket
24	非石棉墊片	Asbestos Free Gasket
25	非石棉墊片	Asbestos Free Gasket
80# (含) 以下用 O 形環及非石棉墊片		
100# (含) 以上用 O 形環		
8,25 O-Ring and Asbestos Free Gasket for Model 100# below		
O-Ring for Model 100# above		
14,15 60# 以下滾珠軸承 Ball Bearing for Model 60# below		

1-STAGE WORM REDUCER W SERIES

單段蝸輪減速機 W 系列

MODEL : HW



▲ 40#~135#

▲ 155#~175#

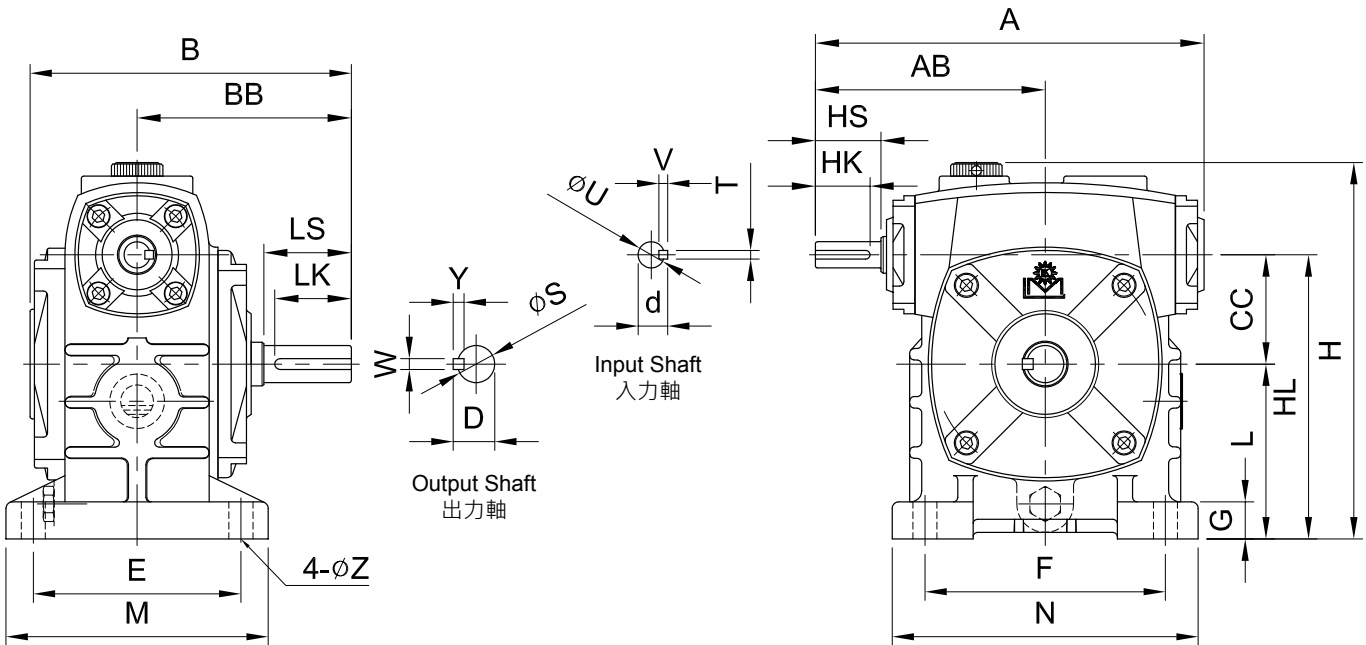
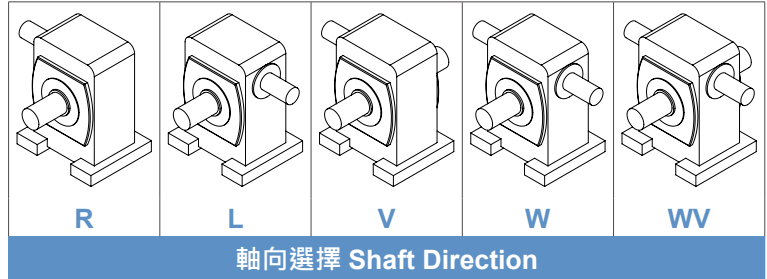

unit: mm

型號 Model	Ratio \ HP		腳座 Foot Stock								入力軸 Input Shaft				出力軸 Output Shaft				重量 Weight (kg)						
	1/10 ~ 1/30	1/40 ~ 1/60	A	AB	B	BB	CC	L	H	HL	E	F	M	N	G	Z	HS	U		d	TxVxHK	LS	S	D	WxYxLK
40	1/8	-	139.5	86	122	80	40	60	139.5	100	89	89	110	112	14	9	25	12	13.5	4x4x20	30	15	17	5x5x25	4
50	1/4	1/8	178	105	146	98	50	80	174.5	130	95	110	120	140	16	11	30	12	13.5	4x4x25	40	17	19	5x5x35	6.6
60	1/2	1/4	198	120	164	110	60	90	200	150	105	120	130	150	20	11	40	15	17	5x5x35	50	22	25	7x7x45	8.2
70	1	1/2	235	140	193	130	70	105	235	175	115	150	150	190	18	15	40	18	20	5x5x35	60	28	31	7x7x55	13.8
80	2	1	268	161	210	140	80	120	260	200	135	180	170	217	20	15	50	22	25	7x7x45	65	32	35	10x8x60	19
100	3	2	323	190	257	170	100	150	324	250	155	220	195	270	25	15	50	25	28	7x7x45	75	38	41	10x8x70	37
120	5	3	391	231	288	190	120	180	383	300	180	260	230	310	30	18	65	30	33	7x7x60	85	45	48	12x8x80	65.2
135	7 1/2	5	438	258	322	214	135	215	445	350	200	290	250	340	32	18	75	35	38	10x8x70	95	55	59	15x10x90	82.2
155	10	7 1/2	491	292	392	253	155	235	482	390	220	320	285	385	38	20	85	40	43	10x8x80	110	60	64	15x10x105	116.8
175	15	10	554	324	411	262	175	260	537	435	250	350	310	410	40	22	85	45	48	12x8x80	110	65	69	18x10x105	143.2

MODEL : LW



▲ 50#~135#



▲ 155#~250#

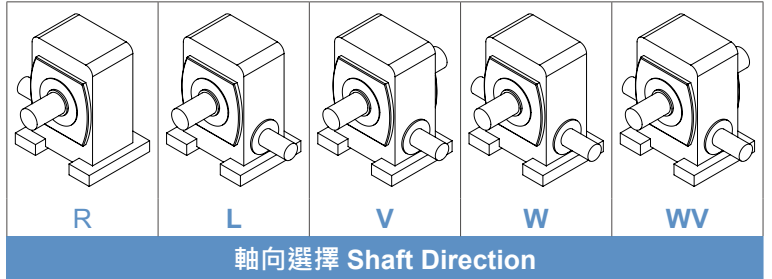

▲ 300#~350#

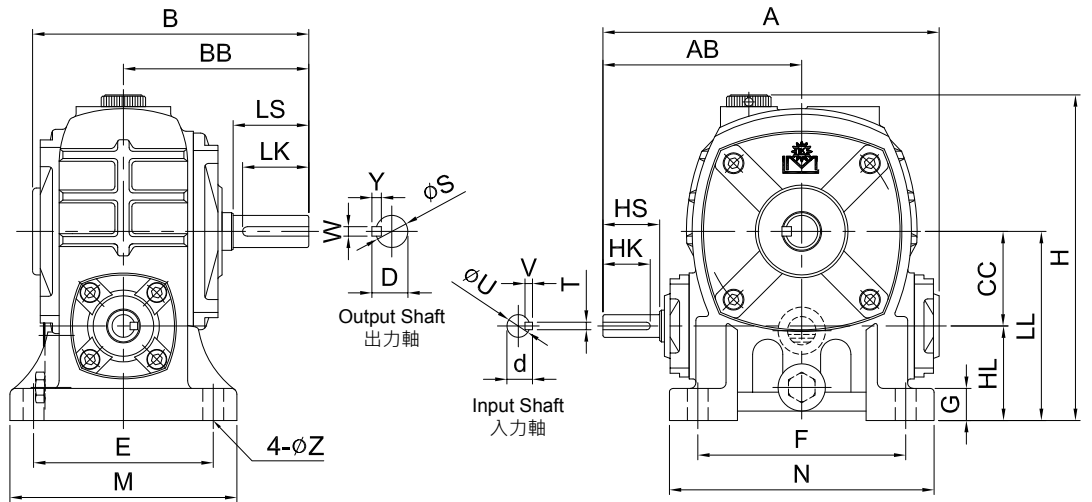

unit: mm

型號 Model	Ratio \ HP		A	AB	B	BB	CC	H	HL	LL	腳座 Foot Stock					入力軸 Input Shaft				出力軸 Output Shaft				重量 Weight (kg)	
	1/10 ~ 1/30	1/40 ~ 1/60									E	F	M	N	G	Z	HS	U	d	TxVxHK	LS	S	D		WxYxLK
50	1/4	-	178	105	149	98	50	173	50	100	95	110	120	140	16	11	30	12	13.5	4x4x25	40	17	19	5x5x35	6.6
60	1/2	1/4	198	120	164	110	60	201	60	120	105	120	130	150	20	11	40	15	17	5x5x35	50	22	25	7x7x45	9
70	1	1/2	235	140	193	130	70	230	70	140	115	150	150	186	18	15	40	18	20	5x5x35	60	28	31	7x7x55	13.4
80	2	1	268	161	210	140	80	260	80	160	135	180	170	214	20	15	50	22	25	7x7x45	65	32	35	10x8x60	19
100	3	2	323	190	259	170	100	335	100	200	155	220	195	270	25	15	50	25	28	7x7x45	75	38	41	10x8x70	36
120	5	3	391	231	288	190	120	398	120	240	180	260	230	310	30	18	65	30	33	7x7x60	85	45	48	12x8x80	59
135	7 1/2	5	438	258	322	214	135	440	135	270	200	290	250	340	32	18	75	35	38	10x8x70	95	55	59	15x10x90	80.6
155	10	7 1/2	491	292	392	253	155	490	135	290	220	320	285	380	38	20	85	40	43	10x8x80	110	60	64	15x10x105	110.4
175	15	10	554	324	411	262	175	560	160	335	250	350	315	415	40	22	85	45	48	12x8x80	110	65	69	18x10x105	151.2
200	20	15	604	352	483	311	200	620	175	375	290	350	360	420	42	22	95	50	53	12x8x90	125	70	74.5	20x12x120	203
225	25	20	650	375	525	335	225	693	190	415	330	390	410	470	45	27	95	55	59	15x10x90	140	80	85	20x12x135	277.2
250	30	25	724	422	555	359	250	784	200	450	380	440	460	520	50	27	110	60	64	15x10x105	155	90	96.5	24x16x150	325
300	40	30	863	498	596	387	300	843	190	490	368	520	450	620	55	36	125	70	73	18x10x120	170	95	101	24x16x160	480
350	50	40	968	570	740	480	350	958	215	565	432	597	520	700	55	43	145	80	85	20x12x135	190	115	124	32x20x185	800

1-STAGE WORM REDUCER W SERIES

單段蝸輪減速機 W 系列

MODEL : LMW

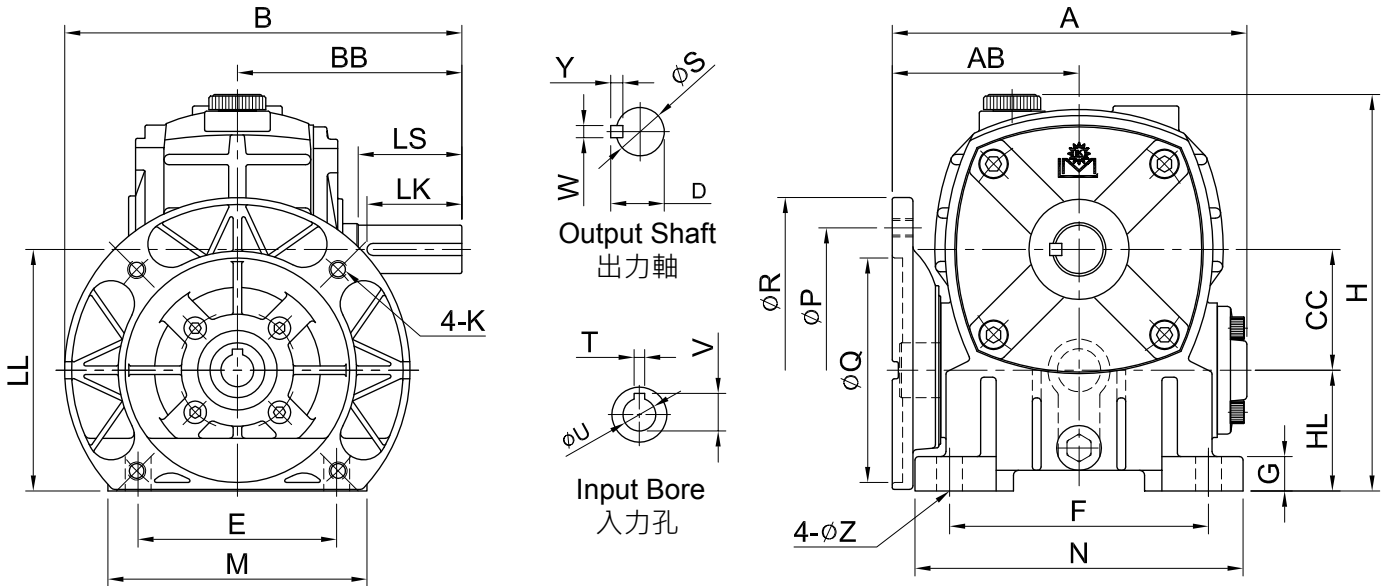
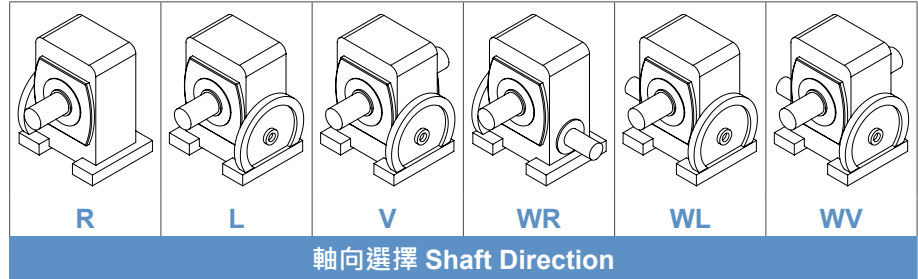

unit: mm

型號 Model	Ratio \ HP		馬達盤 IEC Motor Flange									腳座 Foot Stock					入力孔 Input Bore			出力軸 Output Shaft				重量 Weight (kg)				
	1/10 ~ 1/30	1/40 ~ 1/60	A	AB	B	BB	CC	HL	LL	H	P	Q	R	K	E	F	M	N	G	Z	V	T	U		LS	S	D	WxYxLK
	60	1/2	1/4	165	87	190	110	60	60	120	201	130	110	160	M8	105	120	130	150	20	11	12.7 16.3	4 5		11 14	50	22	25
70	1	1/2	200 206	105 111	210 230	130	70	70	140	230	130 165	110 130	160 200	M8 M10	115	150	150	186	18	15	16.3 21.8	5 6	14 19	60	28	31	7x7x55	14.8
80	2	1	229	121	240	140	80	80	160	260	165	130	200	M10	135	180	170	214	20	15	21.8 27.3	6 8	19 24	65	32	35	10x8x60	20.2
100	3	2	279 283	146 150	270 295	170	100	100	200	335	165 215	130 180	200 248	M10 M12	155	220	195	270	25	15	27.3 31.3	8 8	24 28	75	38	41	10x8x70	37
120	5	3	334	173	315	190	120	120	240	398	215	180	248	M12	180	260	230	310	30	18	31.3	8	28	85	45	48	12x8x80	62.4
135	7 1/2	5	375	194	339 364	214	135	135	270	440	215 265	180 230	248 300	M12	200	290	250	340	30	18	31.3 41.3	8 10	28 38	95	55	59	15x10x90	81
155	10	7 1/2	413	213	403	253	155	135	290	490	265	230	300	M12	220	320	285	380	38	20	41.3	10	38	110	60	64	15x10x105	111.6

1-STAGE WORM REDUCER W SERIES

單段蝸輪減速機 W 系列

MODEL : HOM



Model	N
50	140
60	150
70	190
80	217
100	270
120	310
135	340
155	380
175	415

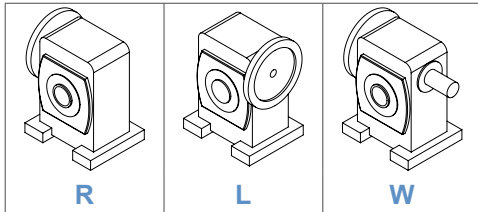
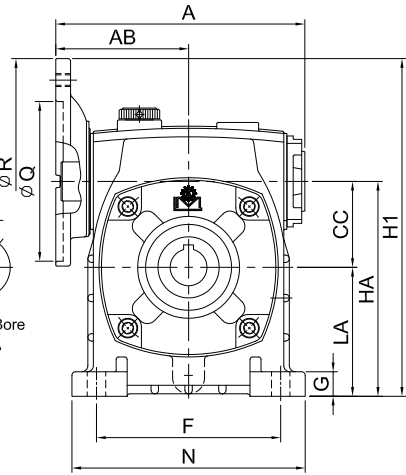
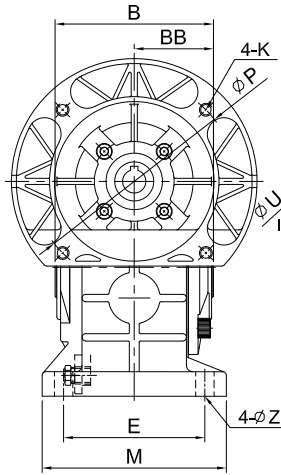

軸向選擇 Shaft Direction

MODEL : LOM



Model	N
50	140
60	150
70	190
80	214
100	270
120	310
135	340
155	380
175	415

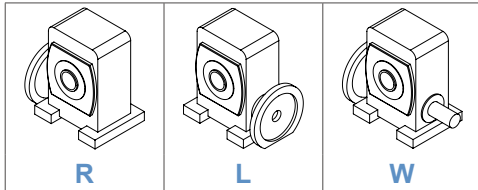
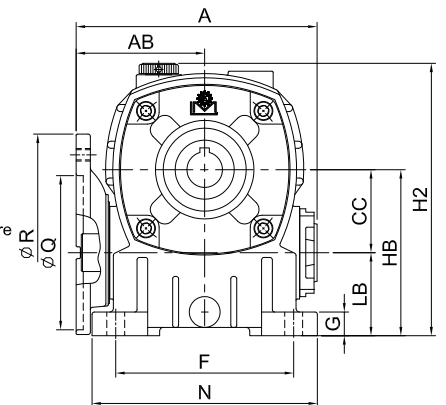
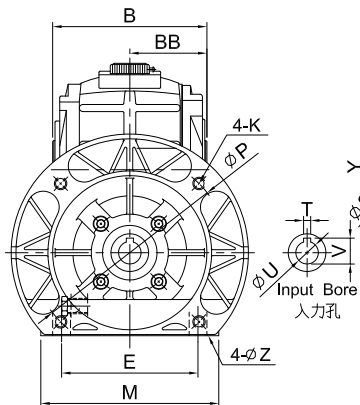

軸向選擇 Shaft Direction

unit: mm

型號 Model	Ratio \ HP		A	AB	B	BB	CC	H1	H2	HA	HB	LA	LB	馬達盤 IEC Motor Flange				腳座 Foot Stock				入力孔 Input Bore			出力孔 Output Bore			重量 Weight (kg)	
	1/10 ~ 1/30	1/40 ~ 1/60												P	Q	R	K	E	F	M	G	Z	V	T	U	W	Y		S
50	1/4	-	154	81	100	50	50	210	172	130	100	80	50	130	110	160	M8	95	110	120	16	11	12.7	4	11	6	22.8	20	8
60	1/2	1/4	165	87	108	54	60	230	200	150	120	90	60	130	110	160	M8	105	120	130	20	11	12.7	4	11	8	28.3	25	10.6
70	1	1/2	200	105	128	64	70	255	235	175	140	105	70	130	110	160	M8	115	150	150	18	15	16.3	5	14	8	33.3	30	18
			206	111				275						130	130	200							M10	21.8	6				
80	2	1	229	121	138	69	80	300	260	200	160	120	80	165	130	200	M10	135	180	170	20	15	21.8	6	19	10	38.3	35	23.2
100	3	2	279	146	178	89	100	350	337	250	200	150	100	165	130	200	M10	155	220	195	25	15	27.3	8	24	10	43.3	40	40.8
			283	150				375						165	180	248							M12	31.3	8				
120	5	3	333	173	198	99	120	425	398	300	240	180	120	215	180	248	M12	180	260	230	30	18	31.3	8	28	12	48.3	45	68.2
			475	440				350						215	180	248							M12	31.3	8				
155	10	7 1/2	412	212	247	123.5	155	540	482	390	290	235	135	265	230	300	M12	220	320	285	35	20	41.3	10	38	15	69.3	65	113.4
			585	482				390						265	230	300							M12	41.3	10				
175	15	10	467	236	262	131	175	610	565	435	335	260	160	265	230	300	M12	250	350	315	40	22	41.3	10	38	18	94.3	90	158.6

MODEL : HOW



Model	N
50	140
60	150
70	190
80	217
100	270
120	310
135	340
155	380
175	415

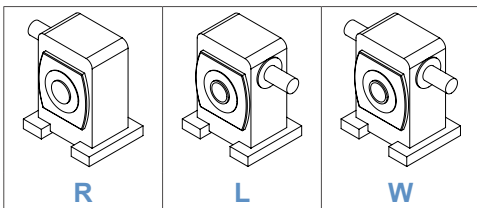
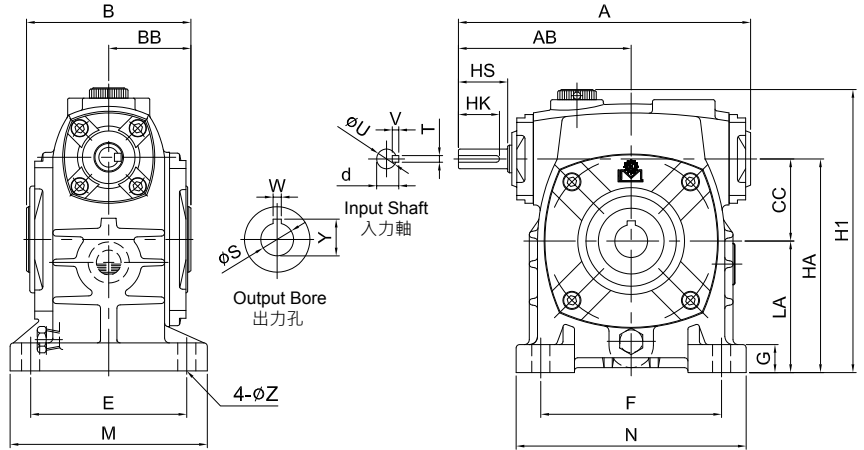

軸向選擇 Shaft Direction

MODEL : LOW



Model	N
50	140
60	150
70	190
80	214
100	270
120	310
135	340
155	380
175	415

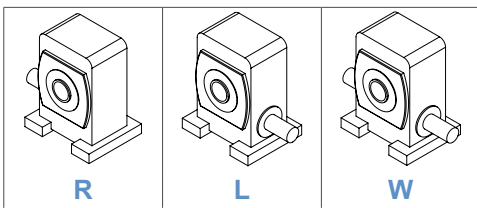
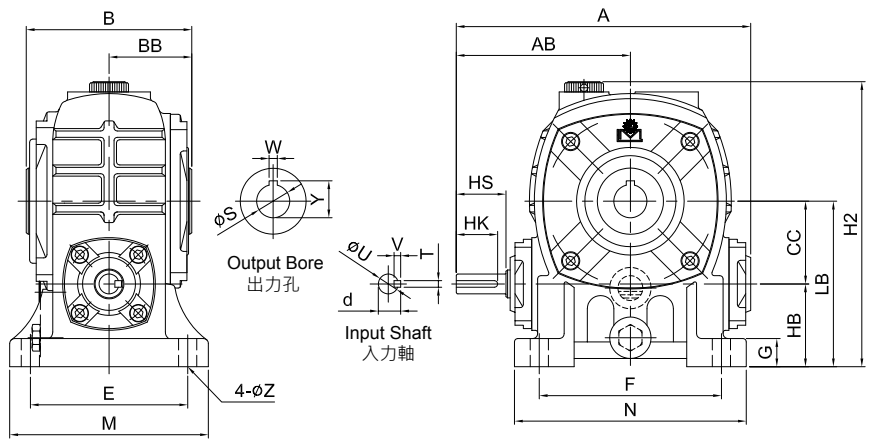

軸向選擇 Shaft Direction

unit: mm

型號 Model	Ratio \ HP		腳座 Foot Stock												輸入軸 Input Shaft					出力孔 Output Bore			重量 Weight (kg)				
	1/10 ~ 1/30	1/40 ~ 1/60	A	AB	B	BB	CC	H1	H2	HA	HB	LA	LB	E	F	M	G	Z	HS	U	d	TxVxHK	W	Y	S	HOW	LOW
	50	1/4	-	179	105	100	50	50	171	172	130	50	80	100	95	110	120	16	11	30	12	13.5	4x4x25	6	22.8	20	7.6
60	1/2	1/4	198	120	108	54	60	200	200	150	60	90	120	105	120	130	20	11	40	15	17	5x5x35	8	28.3	25	10.4	11.4
70	1	1/2	235	140	128	64	70	235	235	175	70	105	140	115	150	150	18	15	40	18	20	5x5x35	8	33.3	30	16.6	16.2
80	2	1	268	161	138	69	80	260	200	200	80	120	160	135	180	170	20	15	50	22	25	7x7x45	10	38.3	35	22	22.2
100	3	2	323	190	178	89	100	324	337	250	100	150	200	155	220	195	25	15	50	25	28	7x7x45	10	43.3	40	37.8	36.8
120	5	3	391	231	198	99	120	380	398	300	120	180	240	180	260	230	30	18	65	30	33	7x7x60	12	48.3	45	65.2	59
135	7 1/2	5	438	258	218	109	135	445	440	350	135	215	270	200	290	250	32	18	75	35	38	10x8x70	15	59.3	55	78	76.4
155	10	7 1/2	491	292	247	123.5	155	482	482	390	135	235	290	220	320	285	35	20	85	40	43	10x8x80	15	69.3	65	112.2	105.8
175	15	10	554	324	262	131	175	536	565	435	160	260	335	250	350	315	40	22	85	45	48	12x8x80	18	94.3	90	159.6	166.6

1-STAGE WORM REDUCER VW SERIES

單段蝸輪減速機 VW 系列

■ VW 系列 Series

VW & UW :

安裝所佔空間小，潤滑效果佳，適合較高扭矩傳動，型號從 40# ~ 350#。

Small space needed for installation; good lubrication effect; suitable for higher torque transmission. Model NO.: 40# to 350#.

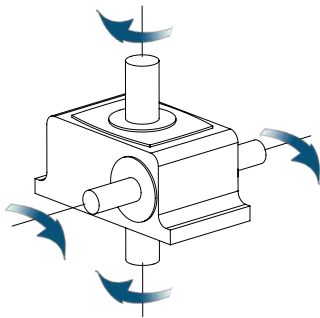

旋轉方向
Rotation Directions

油量表 Oil Capacities (unit: ℓ)

Type Model	VW	UW	VOM	VOW	VWM	UWM	VOWY
40	0.2	0.2		0.2			0.2
50	0.3	0.3	0.3	0.3	0.3	0.3	0.3
60	0.5	0.5	0.5	0.5	0.5	0.5	0.5
70	0.8	0.8	0.8	0.8	0.8	0.8	0.8
80	1.3	1.3	1.3	1.3	1.3	1.3	1.3
100	2.5	2.5	2.5	2.5	2.5	2.5	2.5
120	3.7	3.7	3.7	3.7	3.7	3.7	3.7
135	5.2	5.2	5.2	5.2	5.2	5.2	5.2
155	6.8	6.8	6.7	6.7	6.8	6.8	
175	8.1	8.1	8.0	8.0	8.1	8.1	
200	10.8	10.8					
225	12.2	12.2					
250	15.2	15.2					
300	18.2	18.2					
350	21.3	21.3					

分解系統圖 System Drawing

MODEL : VW

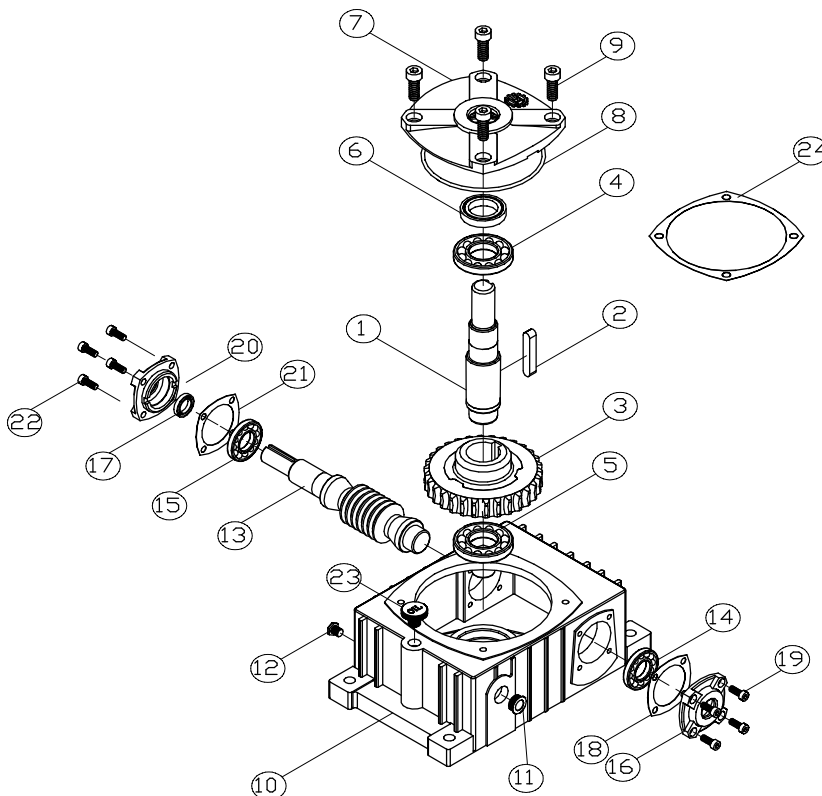

NO.	零件名稱	Name of Parts
1	出力軸	Output Shaft
2	雙圓鍵	Key
3	蝸輪	Worm Wheel
4	滾珠軸承	Ball Bearing
5	滾珠軸承	Ball Bearing
6	油封	Oil Seal
7	出力軸蓋	Output Shaft Cover
8	O 形環	O-Ring
9	六角承窩頭螺絲	Hex Screw
10	蝸輪箱	Outer Shell
11	油鏡	Oil Gauge
12	排油栓	Oil Drain Plug
13	蝸桿	Worm Shaft
14	滾錐軸承	Taper Roller Bearing
15	滾錐軸承	Taper Roller Bearing
16	入力軸蓋	Input Shaft Cover
17	油封	Oil Seal
18	非石棉墊片	Asbestos Free Gasket
19	六角承窩頭螺絲	Hex Screw
20	入力軸蓋 (有孔)	Input Shaft Cover (with bore)
21	非石棉墊片	Asbestos Free Gasket
22	六角承窩頭螺絲	Hex Screw
23	注油栓	Oil Plug
24	非石棉墊片	Asbestos Free Gasket
14,15	60# 以下滾珠軸承	Ball Bearing for Model 60# below

MODEL : VW



▲ 40#~135#



▲ 155#~175#

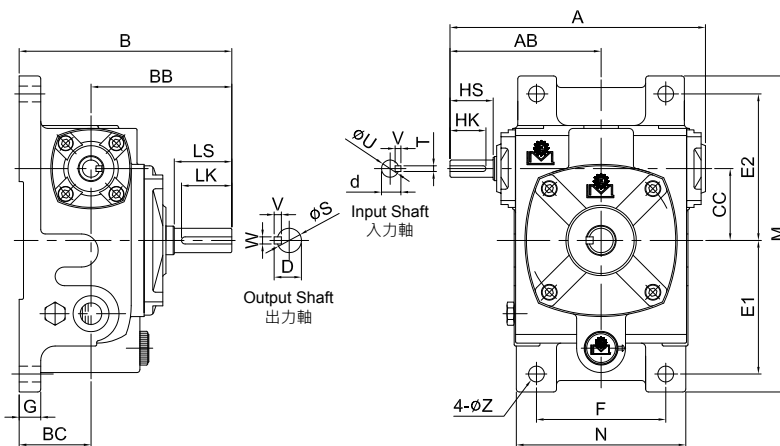
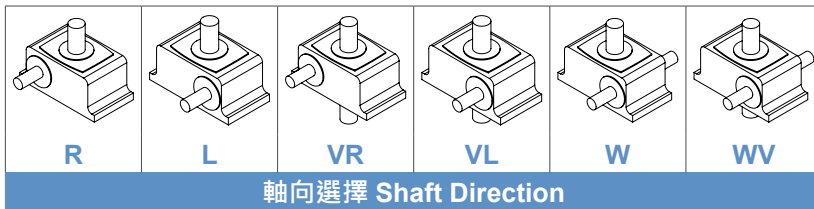

unit: mm

型號 Model	Ratio \ HP		A	AB	B	BB	BC	CC	腳座 Foot Stock						入力軸 Input Shaft				出力軸 Output Shaft				重量 Weight (kg)	
	1/10 ~ 1/30	1/40 ~ 1/60							E1	E2	F	M	N	G	Z	HS	U	d	TxVxHK	LS	S	D		WxYxLK
40	1/8	-	139.5	86	125	80	45	40	75	85	70	182	94	14	9	25	12	13.5	4x4x20	30	15	17	5x5x25	4.5
50	1/4	1/8	178	105	148	98	50	50	93	102	90	220	118	16	11	30	12	13.5	4x4x25	40	17	19	5x5x35	6.8
60	1/2	1/4	198	120	165	110	55	60	105	120	100	252	128	18	11	40	15	17	5x5x35	50	22	25	7x7x45	9.2
70	1	1/2	235	140	195	130	65	70	120	135	120	288	160	20	15	40	18	20	5x5x35	60	28	31	7x7x55	14.4
80	2	1	268	161	210	140	70	80	130	150	140	310	183	20	15	50	22	25	7x7x45	65	32	35	10x8x60	19.4
100	3	2	322	190	260	170	90	100	155	180	190	380	230	26	15	50	25	28	7x7x45	75	38	41	10x8x70	38.6
120	5	3	390	231	290	190	100	120	185	215	220	450	266	30	18	65	30	33	7x7x60	85	45	48	12x8x80	62
135	7 1/2	5	438	258	324	214	110	135	210	235	260	495	305	35	18	75	35	38	10x8x70	95	55	59	15x10x90	83
155	10	7 1/2	491	292	393	253	140	155	145	265	290	460	340	45	20	85	40	43	10x8x80	110	60	64	15x10x105	106.8
175	15	10	555	325	412	262	150	175	167	293	320	516	385	45	22	85	45	48	12x8x80	110	65	69	18x10x105	141



▲ 200#~350#

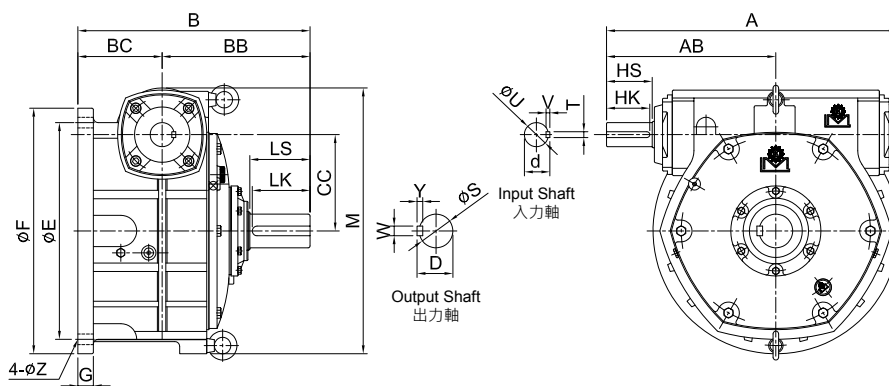

unit: mm

型號 Model	Ratio \ HP		A	AB	B	BB	BC	CC	腳座 Foot Stock					入力軸 Input Shaft				出力軸 Output Shaft				重量 Weight (kg)
	1/10 ~ 1/30	1/40 ~ 1/60							E	F	M	G	Z	HS	U	d	TxVxHK	LS	S	D	WxYxLK	
200	20	15	604	352	486	311	175	200	450	510	558	32	22	95	50	53	12x8x90	125	70	74.5	20x12x120	185.2
225	25	20	650	375	525	335	190	225	510	580	622	35	27	95	55	59	15x10x90	140	80	84.5	20x12x135	255.2
250	30	25	728	422	559	359	200	250	570	640	675	35	27	110	60	64	15x10x105	155	90	96.5	24x16x150	298
300	40	30	864	498	622	387	235	300	660	750	800	38	8-36	125	70	73	18x10x120	170	95	101	24x16x160	465
350	50	40	945	570	770	480	290	350	780	880	945	38	8-38	145	80	85	20x12x135	190	115	124	32x20x185	785

1-STAGE WORM REDUCER VW SERIES

單段蝸輪減速機 VW 系列

MODEL : UW



▲ 40#~135#



▲ 155#~175#

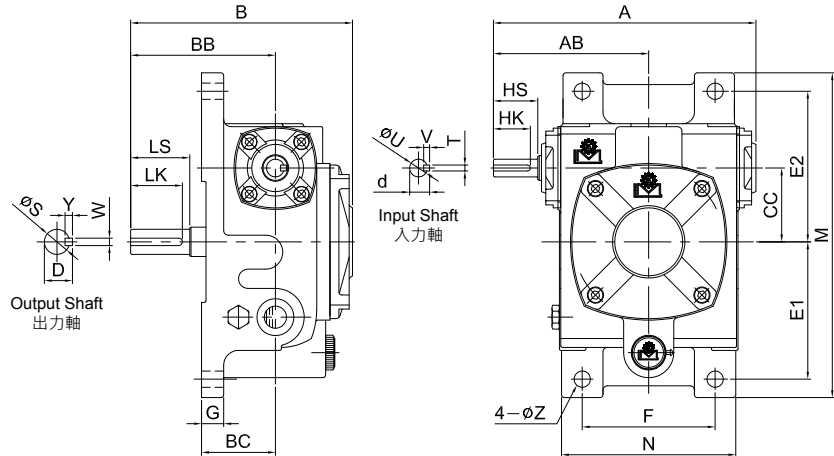
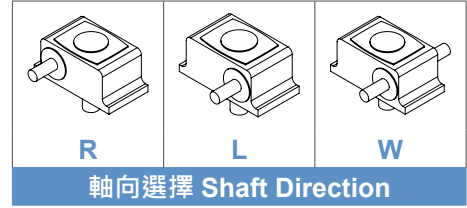

unit: mm

型號 Model	Ratio \ HP		A	AB	B	BB	BC	CC	腳座 Foot Stock						入力軸 Input Shaft				出力軸 Output Shaft				重量 Weight (kg)	
	1/10 ~ 1/30	1/40 ~ 1/60							E1	E2	F	M	N	G	Z	HS	U	d	TxVxHK	LS	S	D		WxYxLK
40	1/8	-	139.5	86	124	80	45	40	75	85	70	182	94	14	9	25	12	13.5	4x4x20	30	15	17	5x5x25	4.5
50	1/4	1/8	178	105	148	98	50	50	93	102	90	220	118	16	11	30	12	13.5	4x4x25	40	17	19	5x5x35	6.8
60	1/2	1/4	198	120	165	110	55	60	105	120	100	252	128	18	11	40	15	17	5x5x35	50	22	25	7x7x45	9.2
70	1	1/2	235	140	195	130	65	70	120	135	120	288	160	20	15	40	18	20	5x5x35	60	28	31	7x7x55	14.4
80	2	1	268	161	210	140	70	80	130	150	140	315	183	20	15	50	22	25	7x7x45	65	32	35	10x8x60	19.4
100	3	2	322	190	260	170	90	100	155	180	190	380	230	26	15	50	25	28	7x7x45	75	38	41	10x8x70	38.6
120	5	3	390	231	290	190	100	120	185	215	220	450	266	30	18	65	30	33	7x7x60	85	45	48	12x8x80	62
135	7 1/2	5	438	258	324	214	110	135	210	235	260	495	305	35	18	75	35	38	10x8x70	95	55	59	15x10x90	83
155	10	7 1/2	491	292	393	253	140	155	145	265	290	460	340	45	20	85	40	43	10x8x80	110	60	64	15x10x105	106.8
175	15	10	555	325	412	262	150	175	167	293	320	516	385	45	22	85	45	48	12x8x80	110	65	69	18x12x105	141



▲ 200#~350#

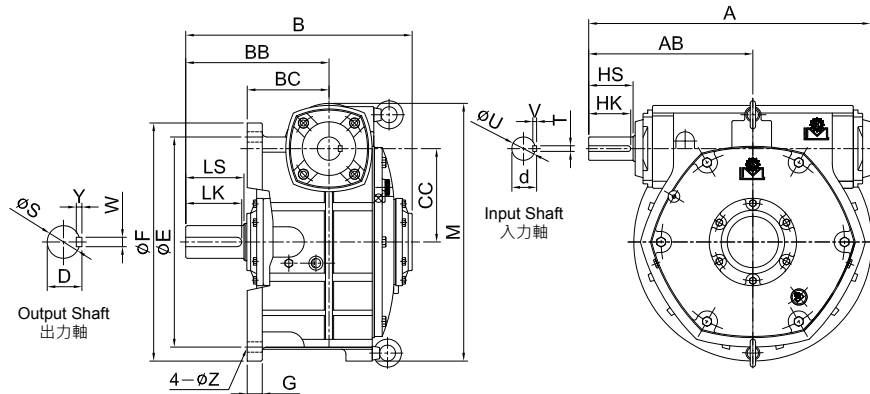

unit: mm

型號 Model	Ratio \ HP		A	AB	B	BB	BC	CC	腳座 Foot Stock						入力軸 Input Shaft				出力軸 Output Shaft				重量 Weight (kg)
	1/10 ~ 1/30	1/40 ~ 1/60							E	F	M	G	Z	HS	U	d	TxVxHK	LS	S	D	WxYxLK		
200	20	15	604	352	486	311	175	200	450	510	558	32	22	95	50	53	12x8x90	125	70	74.5	20x12x120	185.2	
225	25	20	650	375	525	335	190	225	510	580	622	35	27	95	55	59	15x10x90	140	80	85	20x12x135	255.2	
250	30	25	728	422	559	359	200	250	570	640	675	35	27	110	60	64	15x10x105	155	90	96.5	24x16x150	298	
300	40	30	864	498	622	387	235	300	660	750	880	38	36	125	70	73	18x10x120	170	95	101	24x16x160	465	
350	50	40	960	569	770	480	290	350	780	880	945	38	43	145	80	85	20x12x135	190	115	124	32x20x185	785	

MODEL : VMW



▲ 50#~135#



▲ 155#~175#

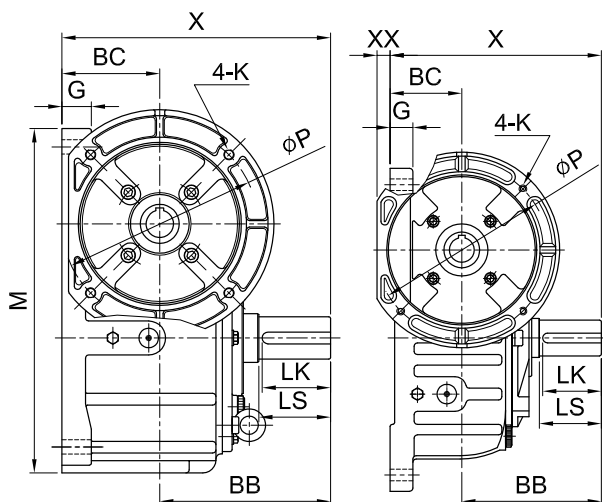
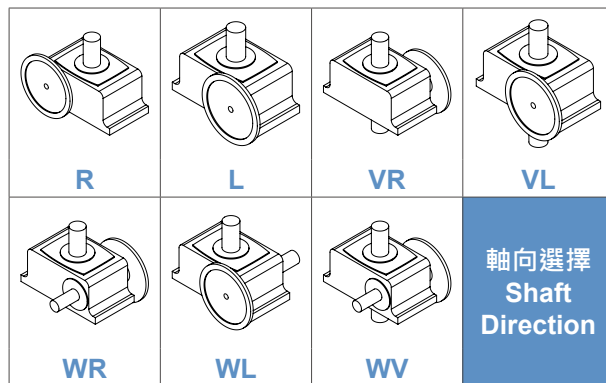

VMW 155~175

VMW 50~135

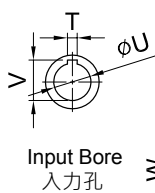

Input Bore 入力孔

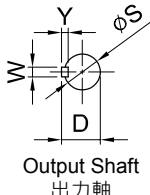

Output Shaft 出力軸

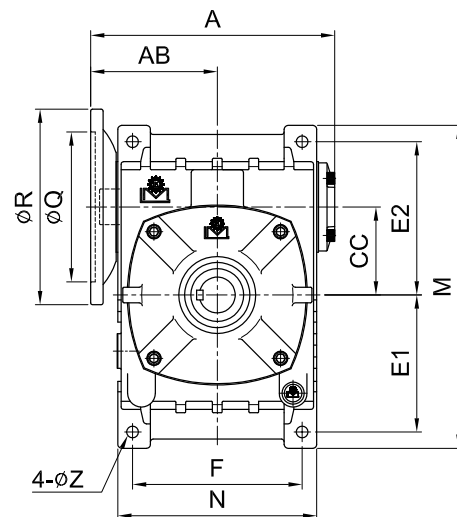

unit: mm

型號 Model	Ratio \ HP		A	AB	X	XX	BB	BC	CC	馬達盤 IEC Motor Flange				腳座 Foot Stock						入力孔 Input Bore			出力軸 Output Shaft				重量 Weight (kg)	
	1/10 ~ 1/30	1/40 ~ 1/60								P	Q	R	K	E1	E2	F	M	N	G	Z	V	T	U	LS	S	D		WxYxLK
50	1/4	-	154	81	148	9	98	50	50	130	110	160	M8	93	102	90	220	118	16	11	12.7	4	11	40	17	19	5x5x35	7.2
60	1/2	1/4	167	86	165	4	110	55	60	130	110	160	M8	105	120	100	252	128	18	11	12.7	4	11	50	22	25	7x7x45	10.2
70	1	1/2	200	105	195	-	130	65	70	130	110	160	M8	120	135	120	288	160	20	15	16.3	5	14	60	28	31	7x7x55	14.4
			206	111						165	130	200	M10								21.8	6	19					
80	2	1	226	118	210	-	140	70	80	165	130	200	M10	130	150	140	315	183	20	15	21.8	6	19	65	32	35	10x8x60	21.2
100	3	2	279	146	260	-	170	90	100	165	130	200	M10	155	180	190	380	230	26	15	27.3	8	24	75	38	41	10x8x70	43
			283	150						215	180	248	M12								31.3	8	28					
120	5	3	335	173	290	-	190	100	120	215	180	248	M12	185	215	220	450	266	30	18	31.3	8	28	85	45	48	12x8x80	65
135	7 1/2	5	369	187	324	-	214	110	135	215	180	248	M12	210	235	260	495	305	35	18	31.3	8	28	95	55	59	15x10x90	85.2
155	10	7 1/2	412	212	393	-	253	140	155	265	230	300	M12	145	265	290	460	340	45	20	41.3	10	38	110	60	64	15x10x105	108
			467	236						265	230	300	M16								41.3	10	38					
175	15	10	467	236	412	-	262	150	175	265	230	300	M16	167	293	320	516	385	45	22	41.3	10	38	110	65	69	18x10x105	150

1-STAGE WORM REDUCER VW SERIES

單段蝸輪減速機 VW 系列

MODEL : UMW

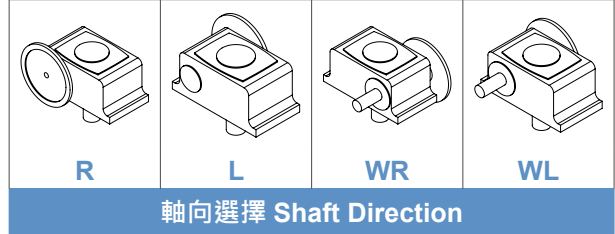
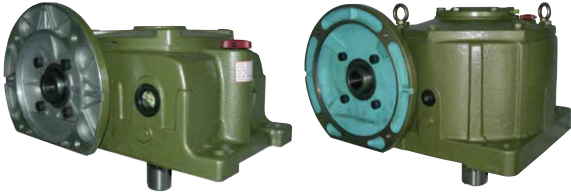

軸向選擇 Shaft Direction

▲ 50#~135#

▲ 155#~175#

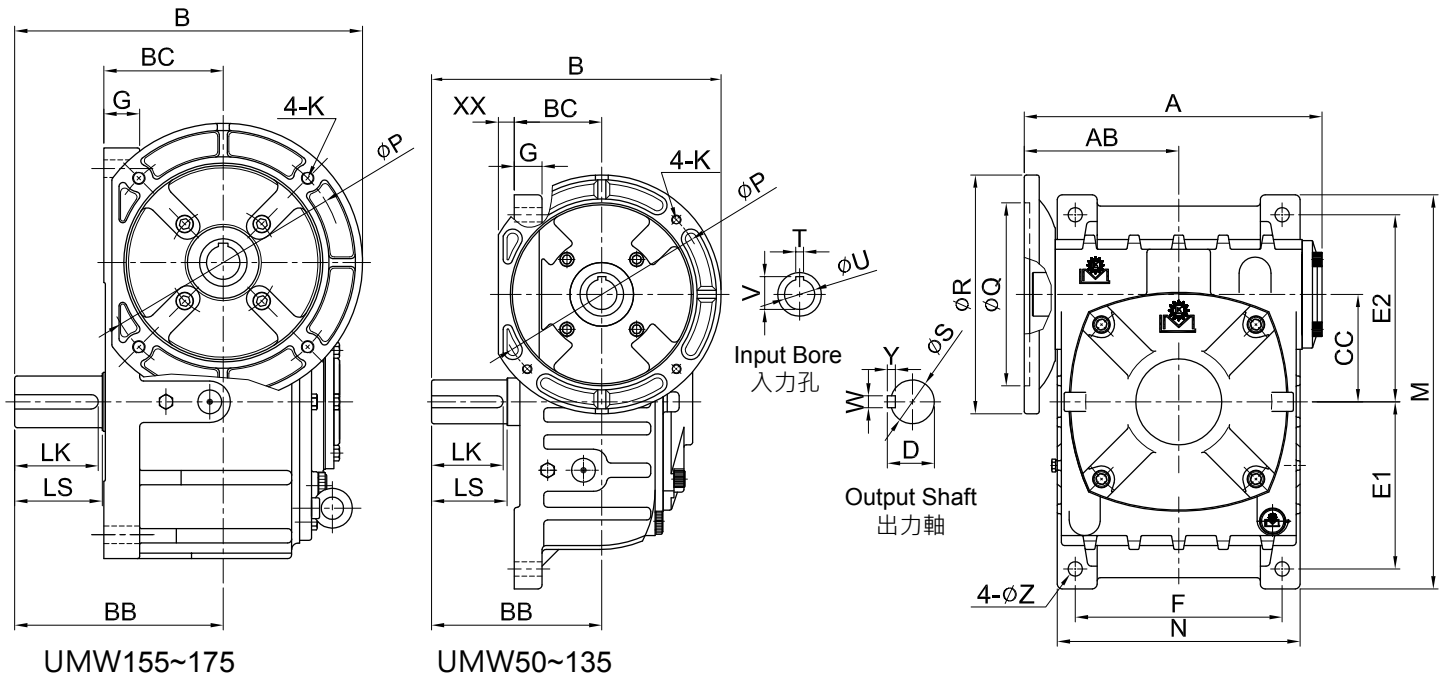

unit: mm

型號 Model	Ratio \ HP		A	AB	B	XX	BB	BC	CC	馬達盤 IEC Motor Flange				腳座 Foot Stock						入力孔 Input Bore			出力軸 Output Shaft				重量 Weight (kg)	
	1/10 ~ 1/30	1/40 ~ 1/60								P	Q	R	K	E1	E2	F	M	N	G	Z	V	T	U	LS	S	D		WxYxLK
50	1/4	-	154	81	178	9	98	50	50	130	110	160	M8	93	102	90	220	118	16	11	12.7	4	11	40	17	19	5x5x35	7.2
60	1/2	1/4	167	87	190	4	110	55	60	130	110	160	M8	105	120	100	252	128	18	11	12.7	4	11	50	22	25	7x7x45	10.2
70	1	1/2	200	105	210	-	130	65	70	130	110	160	M8	120	135	120	288	160	20	15	16.3	5	14	60	28	31	7x7x55	14.4
			206	111	230	4	165	130	200	M10	21.8	6	19															
80	2	1	226	118	240	-	140	70	80	165	130	200	M10	130	150	140	315	183	20	15	21.8	6	19	65	32	35	10x8x60	20.6
			273	8	24	27.3	8	24																				
100	3	2	279	146	270	-	170	90	100	165	130	200	M10	155	180	190	380	230	26	15	27.3	8	24	75	38	41	10x8x70	43
			283	150	295	8	215	180	248	M12	31.3	8	28															
120	5	3	335	173	315	-	190	100	120	215	180	248	M12	185	215	220	450	266	30	18	31.3	8	28	85	45	48	12x8x80	65
			364	20	265	230	300	M12	41.3	10	38																	
135	7 1/2	5	369	187	339	-	214	110	135	215	180	248	M12	210	235	260	495	305	35	18	31.3	8	28	95	55	59	15x10x90	85.2
			364	20	265	230	300	M12	41.3	10	38																	
155	10	7 1/2	412	212	403	-	253	140	155	265	230	300	M12	145	265	290	460	340	45	20	41.3	10	38	110	60	64	15x10x105	108
			412	236	437	-	262	150	175	265	230	300	M16								45.3	12	42					
175	15	10	467	236	412	-	262	150	175	265	230	300	M16	167	293	320	516	385	45	22	41.3	10	38	110	65	69	18x10x105	150
			437	-	262	150	175	265	230	300	M16	45.3	12								42							

MODEL : VOW



▲ 40#~135#



▲ 155#~175#

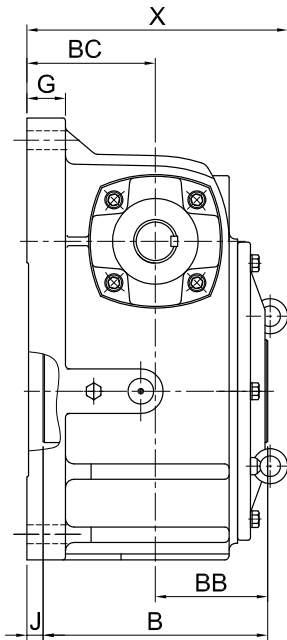
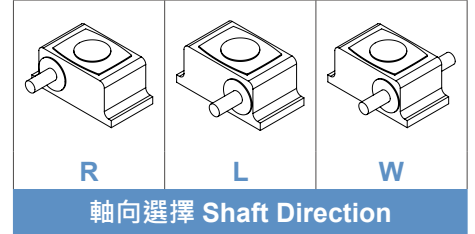

VOW155~175

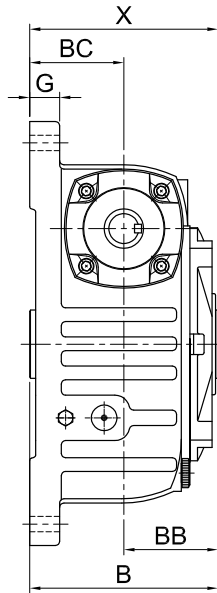

VOW40~135

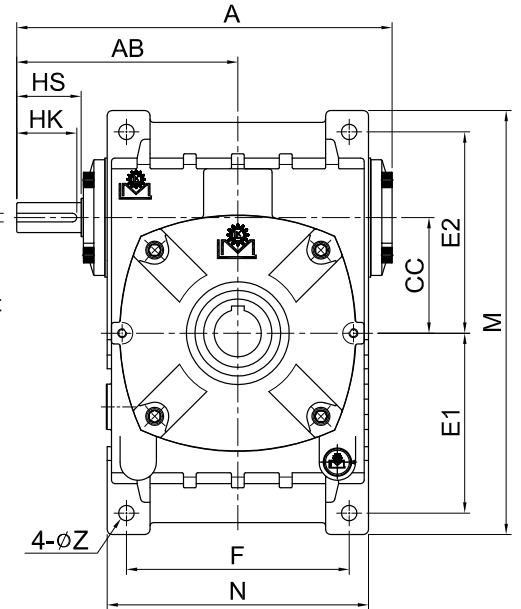
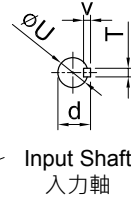
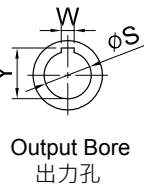

unit: mm

型號 Model	Ratio \ HP		腳座 Foot Stock									入力軸 Input Shaft				出力孔 Output Bore			重量 Weight (kg)						
	1/10 ~ 1/30	1/40 ~ 1/60	A	AB	J	B	X	BB	BC	CC	E1	E2	F	M	N	G	Z	HS		U	d	TxVxHK	W	Y	S
	40	1/8	-	139.5	86	-	88	89	44	45	40	75	85	70	183	94	11	9		25	12	13.5	4x4x20	6	22.8
50	1/4	-	178	105	-	98	99	49	50	50	93	102	90	220	118	16	11	30	12	13.5	4x4x25	6	22.8	20	7.8
60	1/2	1/4	198	120	-	108	109	54	55	60	105	120	100	252	128	18	11	40	15	17	5x5x35	8	28.3	25	12
70	1	1/2	235	140	-	128	129	64	65	70	120	135	120	288	160	20	15	40	18	20	5x5x35	8	33.3	30	15.4
80	2	1	268	161	-	138	139	69	70	80	130	150	140	315	183	20	15	50	22	25	7x7x45	10	38.3	35	21.2
100	3	2	322	190	-	178	179	89	90	100	155	180	190	380	230	26	15	50	25	28	7x7x45	10	43.3	40	39.4
120	5	3	390	231	-	198	199	99	100	120	185	215	220	450	266	30	18	65	30	33	7x7x60	12	48.3	45	62
135	7 1/2	5	438	258	-	218	219	109	110	135	210	235	260	495	305	35	18	75	35	38	10x8x70	15	59.3	55	78.8
155	10	7 1/2	491	292	16.5	247	288	123.5	140	155	145	265	290	460	340	45	20	85	40	43	10x8x80	15	69.3	65	104
175	15	10	555	325	19	262	305	131	150	175	167	293	320	520	390	45	22	85	45	48	12x8x80	18	94.3	90	149

1-STAGE WORM REDUCER VW SERIES

單段蝸輪減速機 VW 系列

MODEL : VOM

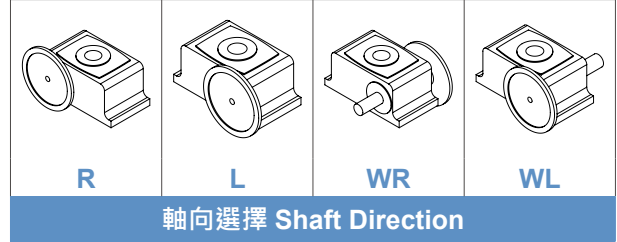
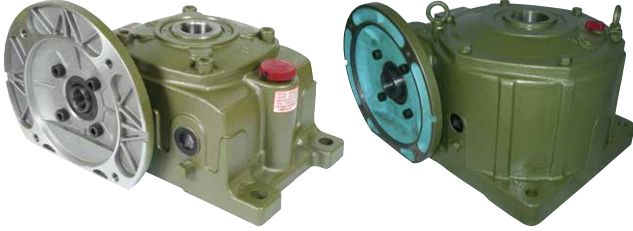

▲ 50#~135#

▲ 155#~175#

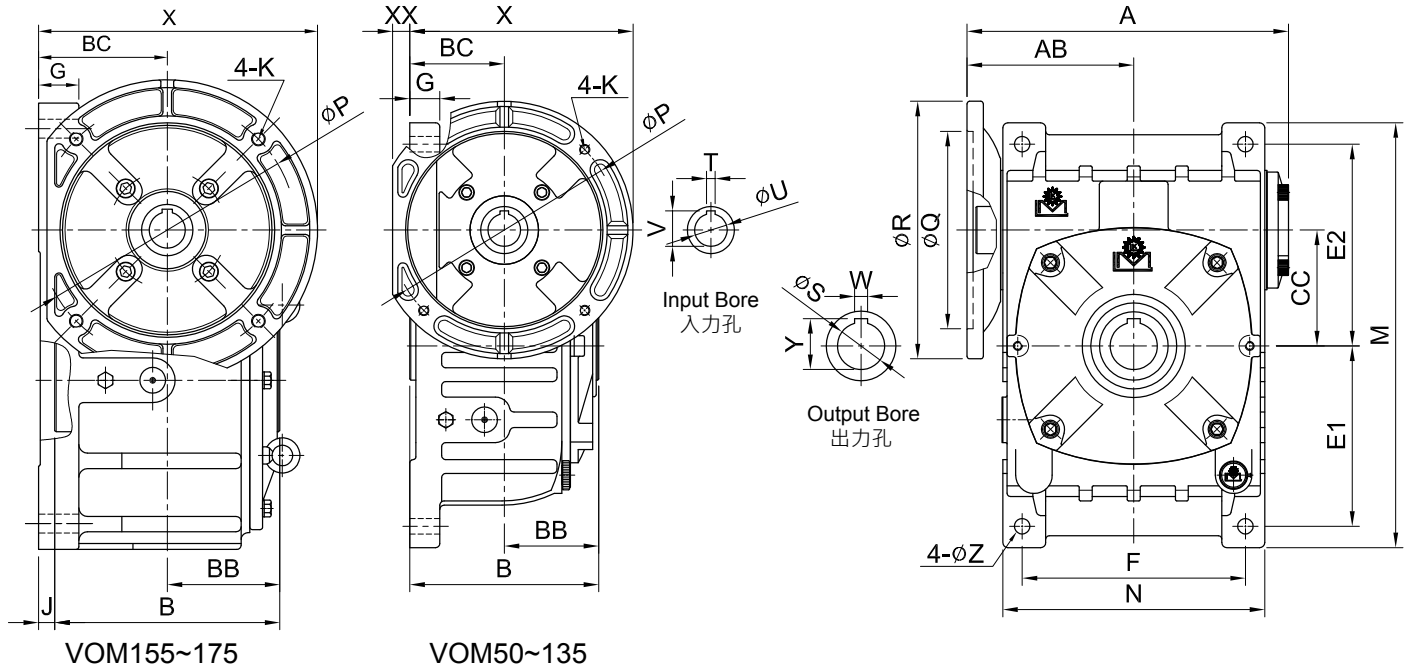

unit: mm

型號 Model	Ratio \ HP		馬達盤 IEC Motor Flange										腳座 Foot Stock						入力孔 Input Bore			出力孔 Output Bore			重量 Weight (kg)				
	1/10 ~ 1/30	1/40 ~ 1/60	A	AB	J	B	X	XX	BB	BC	CC	P	Q	R	K	E1	E2	F	M	N	G	Z	V	T		U	W	Y	S
50	1/4	—	154	81	-	98	130	9	49	50	50	130	110	160	M8	93	102	90	220	118	16	11	12.7	4	11	6	22.8	20	8.2
60	1/2	1/4	167	87	-	111	135	4	54	55	60	130	110	160	M8	105	120	100	252	128	18	11	12.7	4	11	8	28.3	25	11
70	1	1/2	200 206	105 111	-	128	165	- 4	64	65	70	130 165	110 130	160 200	M8 M10	120	135	120	288	160	20	15	16.3 21.8	5 6	14 19	8	33.3	30	15.4
80	2	1	226	118	-	138	170	-	69	70	80	165	130	200	M10	130	150	140	315	183	20	15	21.8 27.3	6 8	19 24	10	38.3	35	22.6
100	3	2	279 283	146 150	- 1	178	215	- 8	89	90	100	165 215	130 180	200 248	M10 M12	155	180	190	380	230	26	15	27.3 31.3	8	24 28	10	43.3	40	40.4
120	5	3	333	173	1	198	225	-	99	100	120	215	180	248	M12	185	215	220	450	266	30	18	31.3	8	28	12	48.3	45	65
135	7 1/2	5	369	187	1	218	234 260	- 20	109	110	135	215 265	180 230	248 300	M12	210	235	260	495	305	35	18	31.3 41.3	8 10	28 38	15	59.3	55	81
155	10	7 1/2	412	212	16.5	247	290	-	123.5	140	155	265	230	300	M12	145	265	290	460	340	45	20	41.3	10	38	15	69.3	65	105.2
175	15	10	467	236	19	262	300 325	-	131	150	175	265 300	230 250	300 350	M12 M16	167	293	320	520	390	45	22	41.3 45.3	10 12	38 42	18	94.3	90	158

MODEL : VOWY

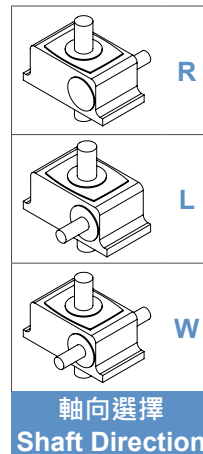
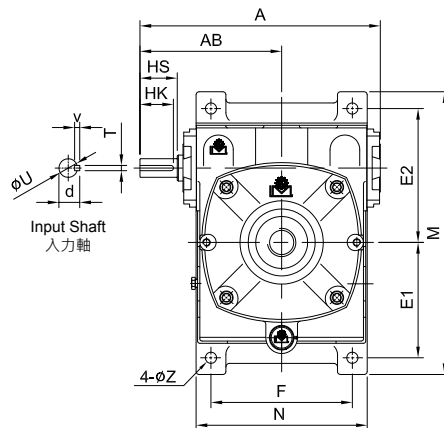
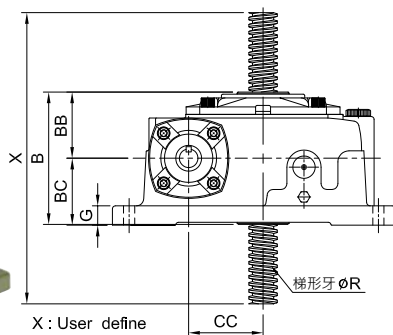

unit: mm

型號 Model	Ratio \ HP		A	AB	B	BB	BC	CC	腳座 Foot Stock						入力軸 Input Shaft				角牙 R"	螺距 inch/ Pitch	重量 Weight (kg)	
	1/10~ 1/30	1/40~ 1/60							E1	E2	F	M	N	G	Z	HS	U	d				TxVxHK
40	1/8	-	139.5	86	88	45	45	40	75	85	70	183	94	11	9	25	12	13.5	4x4x20	1"	4T	4.6
50	1/4	-	178	105	98	50	50	50	93	102	90	220	118	16	11	30	12	13.5	4x4x25	1"	4T	7.2
60	1/2	1/4	198	120	108	55	55	60	105	120	100	252	128	18	11	40	15	17	5x5x35	1"	4T	11.8
70	1	1/2	235	140	128	65	65	70	120	135	120	288	160	20	15	40	18	20	5x5x35	1 1/8"	4T	15.8
80	2	1	268	161	138	70	70	80	130	150	140	315	183	20	15	50	22	25	7x7x45	1 1/4"	4T	21.8
100	3	2	322	190	178	90	90	100	155	180	190	380	230	30	15	50	25	28	7x7x45	1 1/2"	4T	40.4
120	5	3	390	231	198	100	100	120	185	215	220	450	266	30	18	65	30	33	7x7x60	2"	4T	62
135	7 1/2	5	438	258	218	110	110	135	210	235	260	495	305	35	18	75	35	38	10x8x70	2"	4T	78.8

MODEL : VOMY

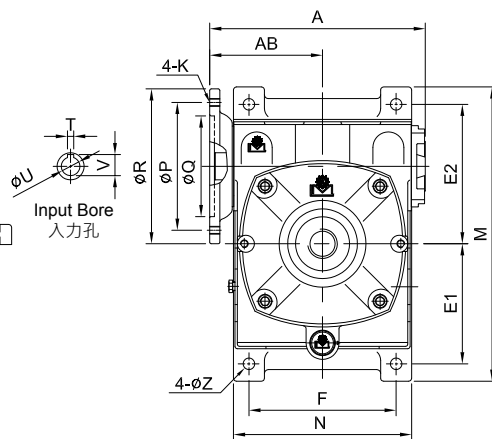
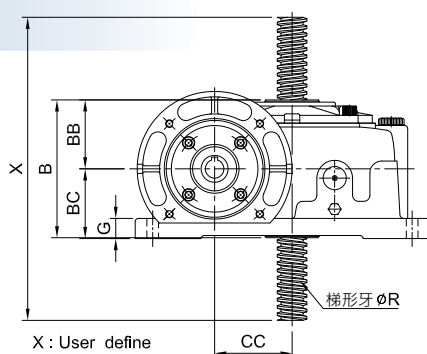

unit: mm

型號 Model	Ratio \ HP		A	AB	B	BB	BC	CC	馬達盤 IEC Motor Flange				腳座 Foot Stock						入力孔 Input Bore			角牙 R"	螺距 inch/ Pitch	重量 Weight (kg)	
	1/10~ 1/30	1/40~ 1/60							P	Q	R	K	E1	E2	F	M	N	G	Z	V	T				U
50	1/4	-	154	81	98	50	50	50	130	110	160	M8	93	102	90	220	118	16	11	12.7	4	11	1"	4T	7.6
60	1/2	1/4	167	87	111	55	55	60	130	110	160	M8	105	120	100	252	128	18	11	12.7	4	11	1"	4T	11.4
70	1	1/2	200	105	128	65	65	70	130	110	160	M8	120	135	120	288	160	20	15	16.3	5	14	1 1/8"	4T	17.6
80	2	1	226	118	138	70	70	80	165	130	200	M10	130	150	140	315	183	20	15	21.8	6	19	1 1/4"	4T	23.2
100	3	2	279	146	178	90	90	100	165	130	200	M10	155	180	190	380	230	26	15	27.3	8	24	1 1/2"	4T	41.4
120	5	3	333	173	198	100	100	120	215	180	248	M12	185	215	220	450	266	30	18	31.3	8	28	2"	4T	65
135	7 1/2	5	369	187	218	110	110	135	215	180	248	M12	210	235	260	495	305	35	18	31.3	8	28	2"	4T	81

1. VOWY·VOMY 減速機只適合輕負荷使用。VOWY & VOMY only used for light loading.
2. VOWY·VOMY 減速機之配合螺桿只生產全牙型。The screw for VOWY & VOMY is "No End Tybe" only.
3. 本公司另有生產螺旋升降器減速機 (J1~J9) 供客戶參考。Please refer to Page J1~J9 for Screw Jack Reducers.

1-STAGE WORM REDUCER WRC SERIES

單段蝸輪減速機 WRC 系列

MODEL : HWRC(WRC)

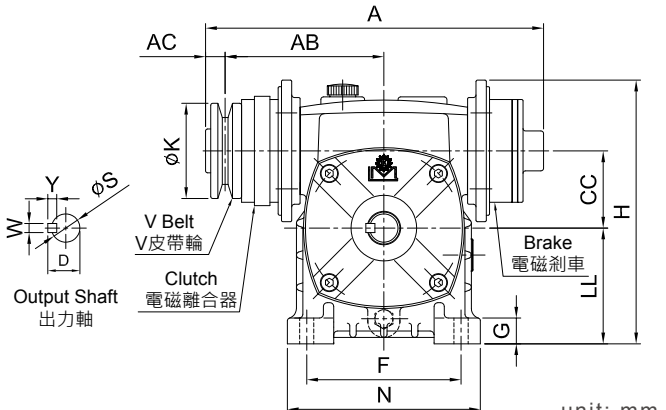
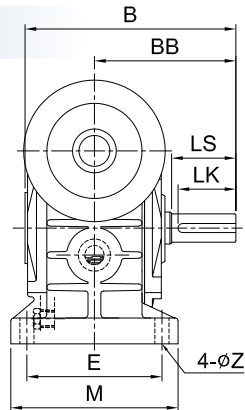

unit: mm

型號 Model	容量 kg	馬力 HP	減速比 Ratio	A	AB	AC	B	BB	CC	K	LL	H	腳座 Foot Stock						出力軸 Output Shaft				重量 Weight (kg)
													E	F	M	N	G	Z	LS	S	D	WxYxLK	
50	0.6	1/4	10~30	246	108	20	149	98	50	76	80	180	95	110	120	140	15	11	40	17	19	5x5x35	7.8
60	0.6	1/4	40~60	250	116	20	164	110	60	76	90	190	105	120	130	150	20	11	50	22	25	7x7x45	9.8
60	1.1	1/2	10~30	254	119	20	164	110	60	102	90	205	105	120	130	150	20	11	50	22	25	7x7x45	9.8
70	1.1	1/2	40~60	287	132	20	193	130	70	102	105	230	115	150	150	190	20	15	60	28	31	7x7x55	15.4
70	2.2	1	10~30	322	145	23	193	130	70	127	105	238	115	150	150	190	20	15	60	28	31	7x7x55	15.4
80	2.2	1	40~60	338	152	23	210	140	80	127	120	270	135	180	170	217	20	15	65	32	35	10x8x60	21.2
80	2.2	2	10~30	338	152	23	210	140	80	127	120	270	135	180	170	217	20	15	65	32	35	10x8x60	21.2
100	4.4	2	40~60	419	214	23	260	170	100	127	150	332	155	220	195	270	25	15	75	38	41	10x8x70	41.2
100	4.4	3	10~30	419	214	23	260	170	100	127	150	332	155	220	195	270	25	15	75	38	41	10x8x70	41.2
120	8	3 5	40~60 10~30	504	227	32	288	190	120	210	180	405	180	260	230	310	30	18	85	45	48	12x8x80	70

MODEL : VWRC

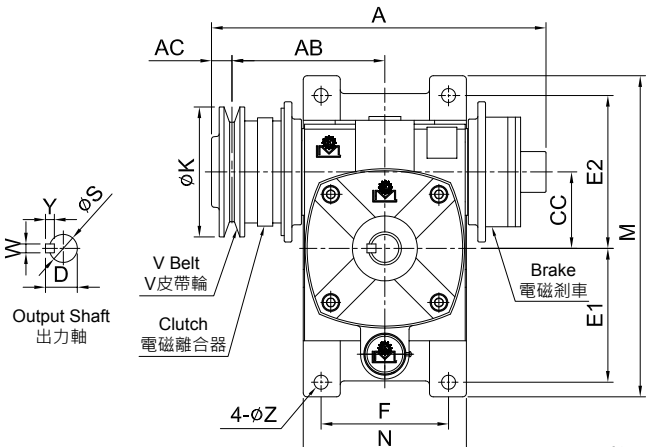
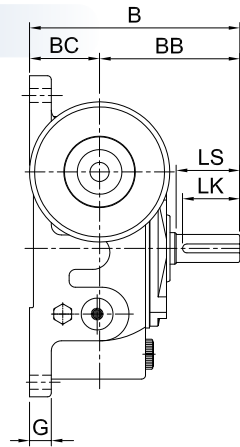

unit: mm

型號 Model	容量 kg	馬力 HP	減速比 Ratio	A	AB	AC	B	BB	CC	K	BC	腳座 Foot Stock						出力軸 Output Shaft				重量 Weight (kg)	
												E2	E1	F	M	N	G	Z	LS	S	D		WxYxLK
50	0.6	1/4	10~30	326	108	20	148	98	50	76	50	102	93	90	220	118	15	11	40	17	19	5x5x35	8
60	0.6	1/4	40~60	250	116	20	165	110	60	76	55	120	105	100	252	128	18	11	50	22	25	7x7x45	10.8
60	1.1	1/2	10~30	254	119	20	165	110	60	102	55	120	105	100	252	128	18	11	50	22	25	7x7x45	10.8
70	1.1	1/2	40~60	287	132	20	195	130	70	102	65	135	120	120	288	160	20	15	60	28	31	7x7x55	16
70	2.2	1	10~30	322	145	23	195	130	70	127	65	135	120	120	288	160	20	15	60	28	31	7x7x55	16
80	2.2	1	40~60	338	152	23	210	140	80	127	70	150	130	140	315	180	20	15	65	32	35	10x8x60	21.6
80	2.2	2	10~30	338	152	23	210	140	80	127	70	150	130	140	315	180	20	15	65	32	35	10x8x60	21.6
100	4.4	2	40~60	419	214	23	260	170	100	127	90	180	155	190	380	230	30	15	75	38	41	10x8x70	42.8
100	4.4	3	10~30	419	214	23	260	170	100	127	90	180	155	190	380	230	30	15	75	38	41	10x8x70	42.8
120	8	3 5	40~60 10~30	504	227	32	290	190	120	210	100	215	185	220	450	266	30	18	85	45	48	12x8x80	66.8

HWRC(WRC) - VWRC 電磁剎車 / 離合器定格電壓 DC 24V(需另外訂購)。

HWRC (WRC), VWRC electromagnetic brake / clutch rated voltage DC 24V (must be ordered separately).

MODEL : VMP

裝配油壓馬達用 For Hydraulic Motor

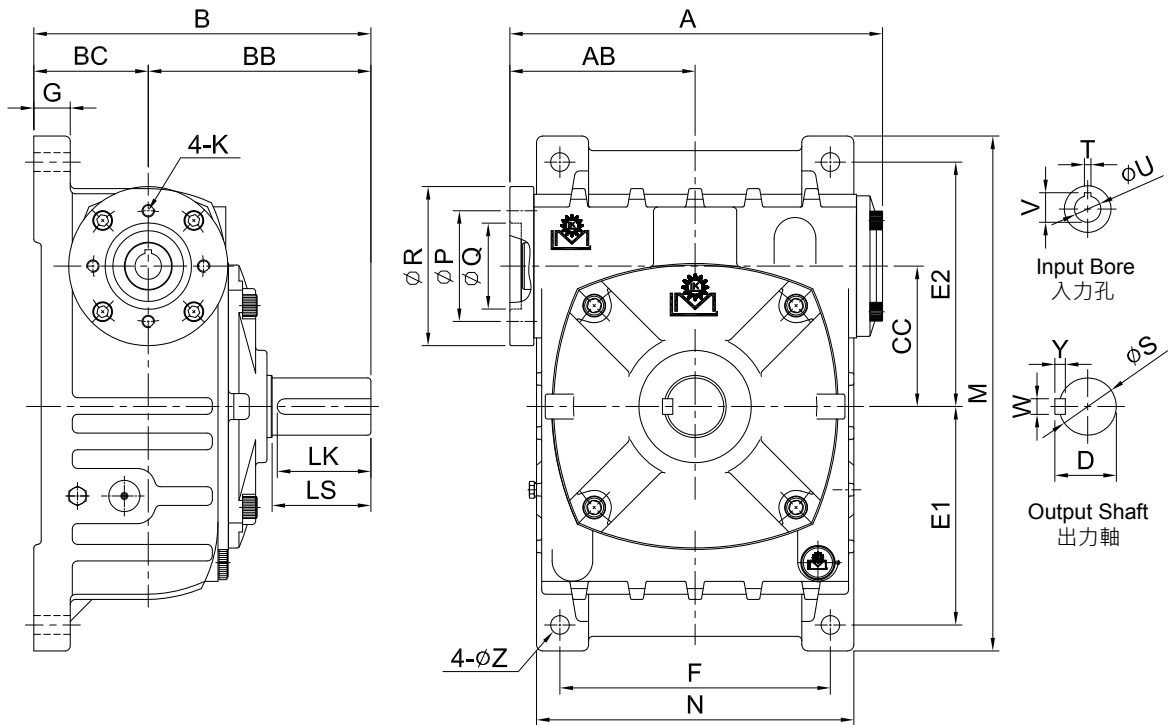

unit: mm

型號 Model	A	AB	B	BB	BC	CC	油壓盤 Motor Flange				腳座 Foot Stock				入力孔 Input Bore				出力軸 Output Shaft				重量 Weight (kg)		
							P	Q	R	K	E1	E2	F	M	N	G	Z	V	T	U	LS	S		D	WxYxLK
100	278	143.5	260	170	90	100	106.5	82.55	133	M12	155	180	190	380	230	26	15	28.2	6.35	25.4	75	38	41	10x8x70	41
120	314	155	290	190	100	120	106.5	82.55	145	M12	185	215	220	452	266	30	18	28.2	6.35	25.4	85	45	48	12x8x80	63.6
135	358	178	324	214	110	135	106.5	82.55	153	M12	210	235	260	497	306	35	18	28.2	6.35	25.4	95	55	59	15x10x90	84
155	396	197	393	253	140	155	106.5	82.55	153	M12	145	265	290	464	345	45	20	28.2	6.35	25.4	110	60	64	15x10x105	116.8
175	457	227.5	412	262	150	175	106.5	82.55	174	M12	167	293	320	520	385	45	20	28.2	6.35	25.4	110	65	69	18x10x105	148.4

WORM REDUCER E SERIES

蝸輪減速機 E 系列

E 系列 Series

特點 Features

體積小、重量輕，任意安裝方向，可附加腳座，安裝方式多變化，型號從 40# ~ 135#。

Small size, light weight, free installation direction, with base kits, various installation methods, Model No.: 40# to 135#.

油量表 Oil Capacities (unit: ℓ)

Type Model	E EM	EO EOM	EOV	EOVM	LD	LDM	TW	TM	VOF VOFM
40	0.2	0.2	-	-	-	-	-	-	-
50	0.3	0.3	0.4	0.4	-	-	0.3	0.3	-
60	0.5	0.5	0.5	0.5	-	-	0.4	0.4	-
70	0.8	0.8	0.8	0.8	1.5	1.5	0.9	0.9	0.6
80	1.2	1.2	1.2	1.2	2.5	2.5	1.2	1.2	1.0
100	2.6	2.6	2.6	2.6	4.7	4.7	2.6	2.6	1.6
120	4.5	4.5	4.5	4.5	-	-	3.9	3.9	2.4
135	7.2	7.2	7.2	7.2	6.4	6.4	4.8	4.8	3.5

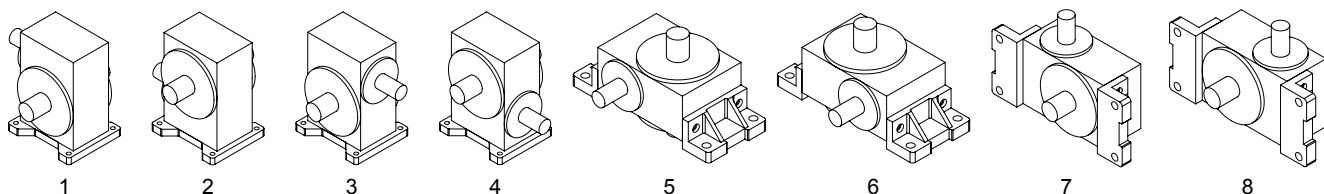

分解系統圖 System Drawing

MODEL : E

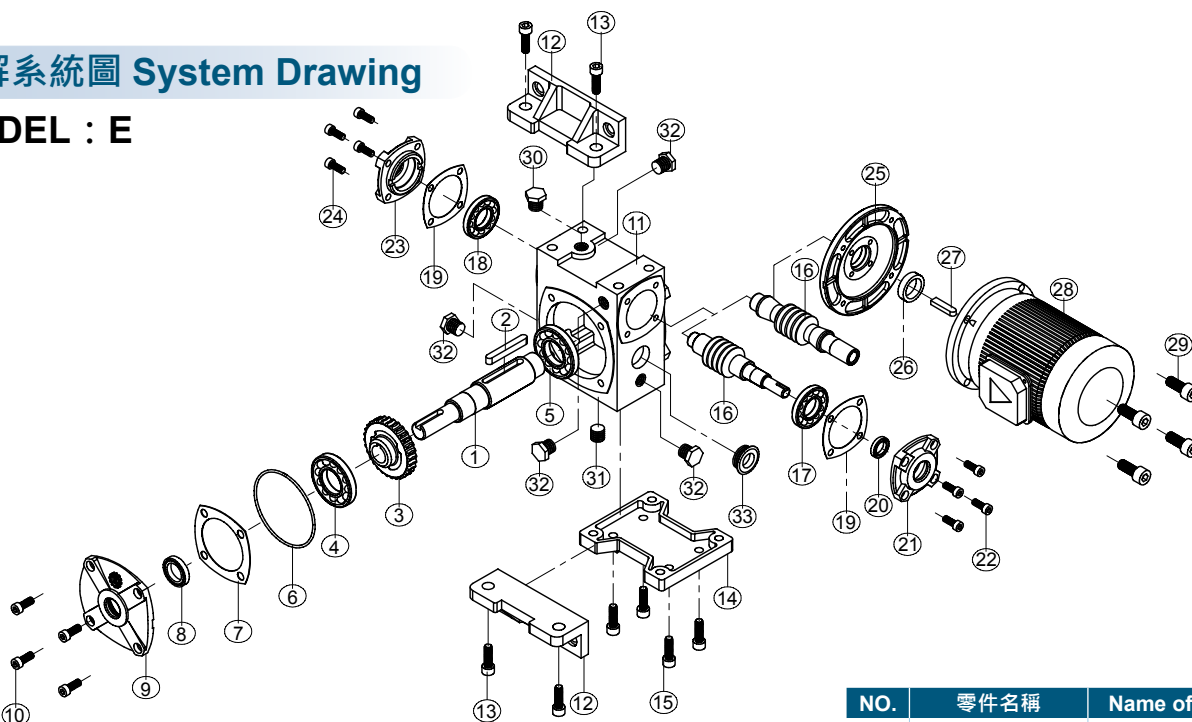

NO.	零件名稱	Name of Parts	NO.	零件名稱	Name of Parts
1	出力軸	Output Shaft	12	L 型腳座	Base Kits (L)
2	雙圓鍵	Key	13	六角承窩頭螺絲	Hex Screw
3	蝸輪	Worm Wheel	14	H 型腳座	Base Kits (H)
4	滾珠軸承	Ball Bearing	15	六角承窩頭螺絲	Hex Screw
5	滾珠軸承	Ball Bearing	16	蝸桿	Worm Shaft (Input Shaft)
6	O 形環	O-Ring	17	滾錐軸承	Taper Roller Bearing
7	非石棉墊片	Asbestos Free Gasket	18	滾錐軸承	Taper Roller Bearing
8	油封	Oil Seal	19	非石棉墊片	Asbestos Free Gasket
9	出力軸蓋	Output Shaft Cover	20	油封	Oil Seal
10	六角承窩頭螺絲	Hex Screw	21	入力軸蓋 (有孔)	Input Shaft Cover (with bore)
11	蝸輪箱	Worm Wheel	22	六角承窩頭螺絲	Hex Screw

NO.	零件名稱	Name of Parts
23	入力軸蓋	Input Shaft Cover
24	六角承窩頭螺絲	Hex Screw
25	馬達盤	Motor Flange
26	油封	Oil Seal
27	單圓鍵	Key
28	馬達	Motor
29	六角承窩頭螺絲	Hex Screw
30	注油栓	Oil Plug
31	沉頭油栓	Plug
32	洩油栓	Drain Plug
33	油鏡	Oil Gauge
17,18	60# 以下滾珠軸承	Ball Bearing for Model 60# below

H 型腳座 H Type Base Kits

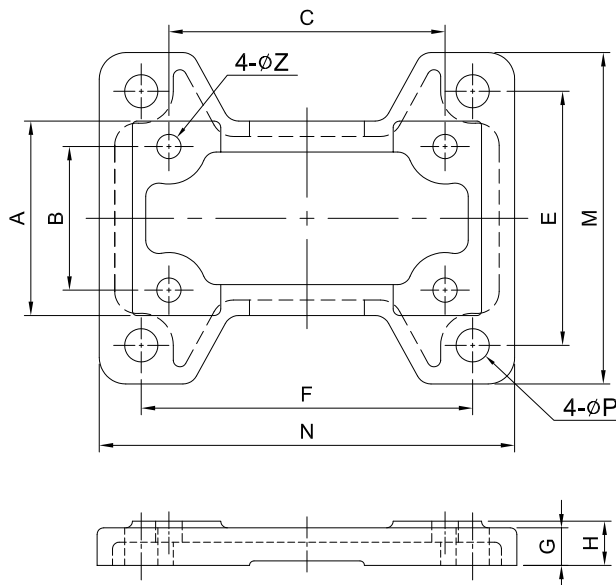
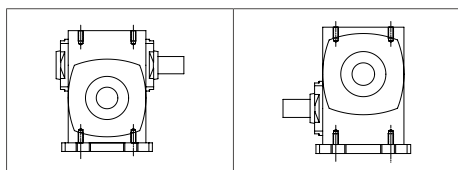

unit: mm

型號 Model	A	B	C	E	F	G	H	M	N	P	Z	重量 Weight (kg)
40	55	35	76	71	80	12	12	97	104	14x9	7	0.2
50	70	50	90	95	110	13	15	120	140	11	9	0.5
60	80	55	100	105	120	15	18	130	150	11	11	1
70	88	65	125	115	150	17	20	150	188	15	12	1
80	100	75	145	135	180	17	20	168	218	15	12	1.5
100	118	85	185	155	220	21	25	188	268	15	12	2.5
120	132	100	220	180	260	21	25	230	320	18	15	4.6
135	145	110	260	200	290	25	30	250	350	18	17	5.8

L 型腳座 L Type Base Kits

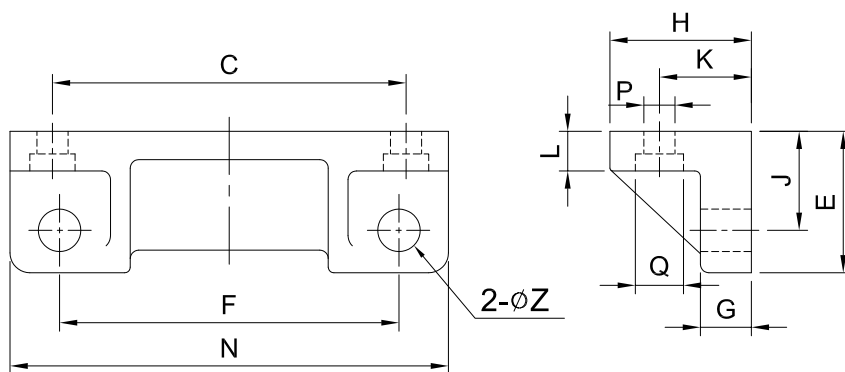
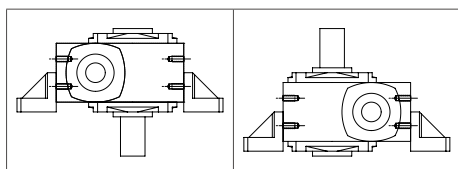

unit: mm

型號 Model	C	E	F	G	H	J	K	L	N	P	Q	Z	重量 Weight (kg)
50	90	40	90	14	40	25	25	9	115	9	14	11	1
60	100	45	100	15	45	30	27.5	12	126	11	17	11	2
70	125	50	120	18	50	35	32.5	14	155	11	17	15	2.5
80	145	60	140	20	52	40	32.5	18	174	11	17	15	4
100	185	60	190	20	70	40	47.5	18	224	13	19	15	4
120	220	62.5	220	24	80	40	50	18	264	15	21	18	6
135	260	67.5	260	28	77	45	55	24	304	17	26	18	5.1

WORM REDUCER E SERIES

蝸輪減速機 E 系列

MODEL : E

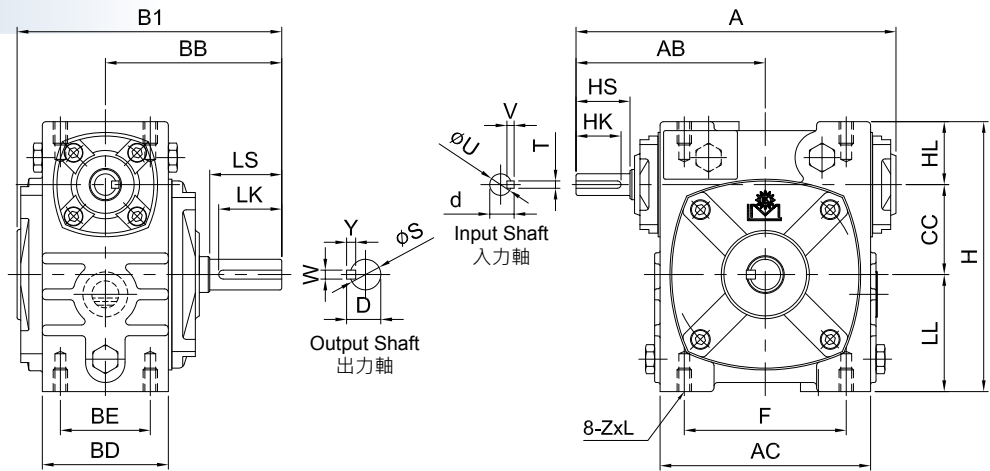

MODEL : EO

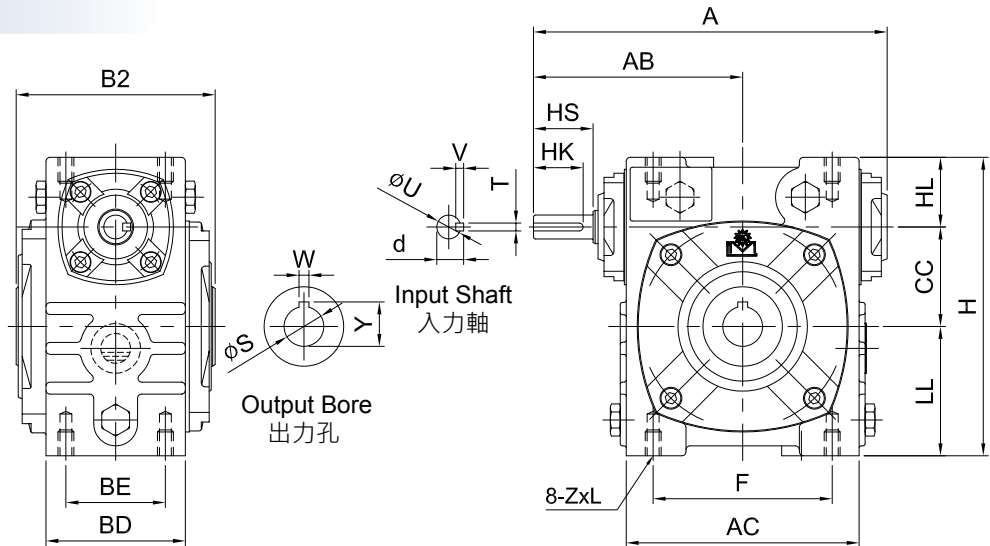

unit: mm

型號 Model	出力孔 Output Bore		
	W	S	Y
40	6	20	22.8
50	6	20	22.8
60	8	25	28.3
70	8	30	33.3
80	10	35	38.3
100	10	40	43.3
120	12	45	48.3
135	15	55	59.3

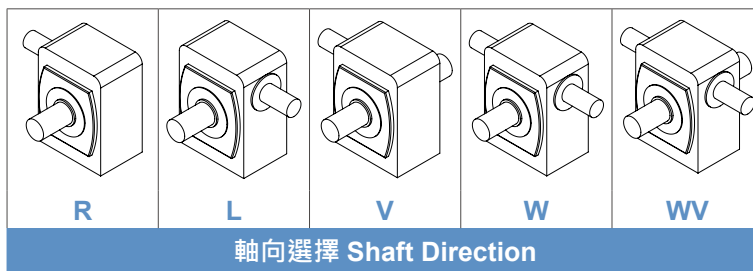

軸向選擇 Shaft Direction

unit: mm

型號 Model	Ratio \ HP		A	AB	B1	B2	BB	CC	HL	LL	H	腳座 Foot Stock					入力軸 Input Shaft				出力軸 Output Shaft				重量 Weight (kg)	
	1/10~1/30	1/40~1/60										AC	F	BD	BE	ZxL	HS	U	d	TxVxHK	LS	S	D	WxYxLK	E	EO
40	1/8	-	139.5	86	122	88	80	40	28	48	116	92	76	55	35	M6x12	25	12	13.5	4x4x20	30	15	17	5x5x25	3	4
50	1/4	-	178	105	147	100	98	50	35	65	150	115	90	70	50	M8x16	30	12	13.5	4x4x25	40	17	19	5x5x35	6.2	7.2
60	1/2	1/4	198	120	165	108	110	60	42	75	177	124	100	77	55	M10x18	40	15	17	5x5x35	50	22	25	7x7x45	9.2	10.4
70	1	1/2	235	140	193	128	130	70	50	85	205	154	125	85	65	M10x18	40	18	20	5x5x35	60	28	31	7x7x55	14	14.2
80	2	1	268	161	208	138	140	80	60	92	232	174	145	96	75	M10x18	50	22	25	7x7x45	65	32	35	10x8x60	18.4	20.4
100	3	2	323	190	258	178	170	100	75	115	290	225	185	116	85	M12x20	50	25	28	7x7x45	75	38	41	10x8x70	34.6	35.4
120	5	3	391	231	288	198	190	120	95	155	370	264	220	132	100	M14x28	65	30	33	7x7x60	85	45	48	12x8x80	56.8	58.2
135	7 1/2	5	438	258	319	218	214	135	105	185	425	306	260	150	110	M16x30	75	35	38	10x8x70	95	55	59	15x10x90	81.2	78.8

MODEL : EM

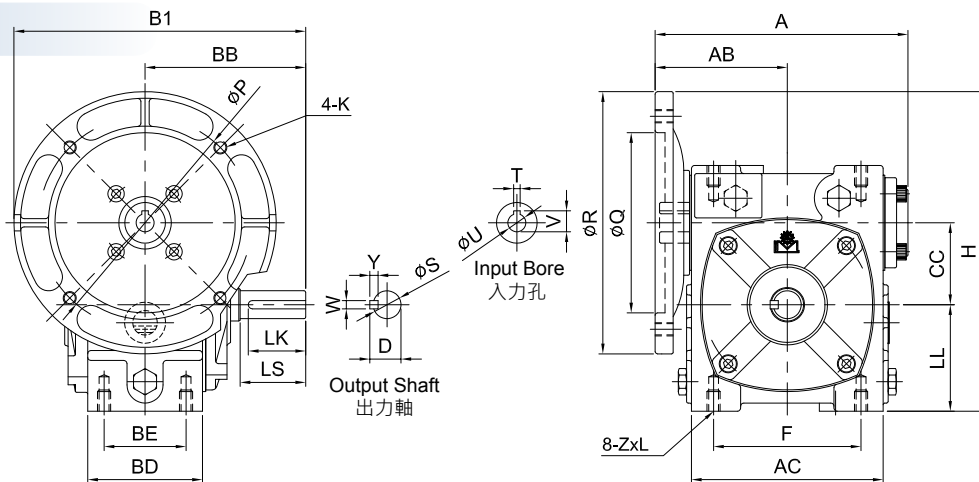

MODEL : EOM

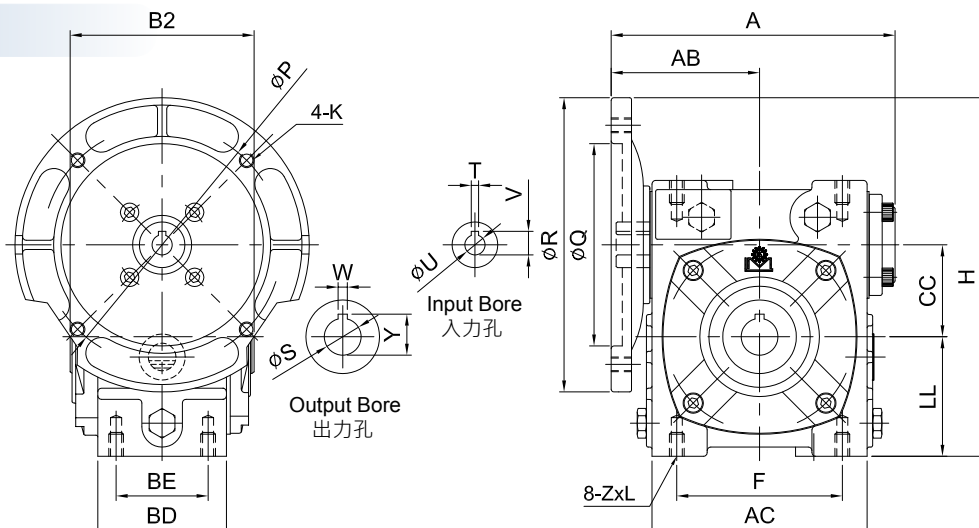

unit: mm

型號 Model	出力孔 Output Bore		
	S	W	Y
50	20	6	22.8
60	25	8	28.3
70	30	8	33.3
80	35	10	38.3
100	40	10	43.3
120	45	12	48.3
135	55	15	59.3

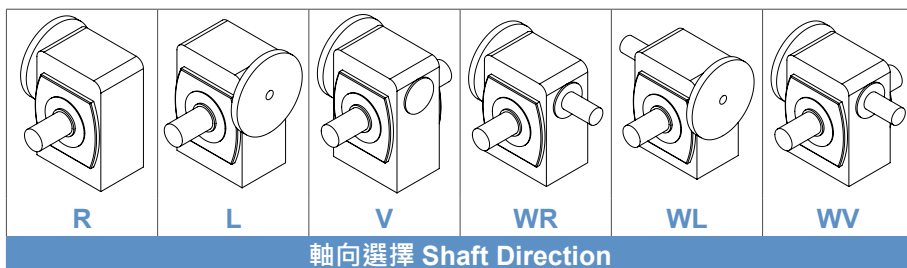

軸向選擇 Shaft Direction

unit: mm

型號 Model	Ratio \ HP		腳座 Foot Stock										馬達盤 IEC 及入力孔 Motor Flange & Input Bore								出力軸 Output Shaft						重量 Weight (kg)	
	1/10~ 1/30	1/40~ 1/60	A	AB	B1	B2	BB	CC	LL	H	AC	F	BD	BE	ZxL	P	Q	R	K	V	T	U	LS	S	D	WxYxLK	EM	EOM
	50	1/4	-	154	81	178	100	98	50	65	195	115	90	70	50	M8x16	130	110	160	M8	12.7	4	11	40	17	19	5x5x35	6.6
60	1/2	1/4	165	87	190	108	110	60	75	215	124	100	77	55	M10x18	130	110	160	M8	12.7	4	11	50	22	25	7x7x45	9.4	10.6
70	1	1/2	200	105	210	128	130	70	85	235	154	125	85	65	M10x18	130	110	160	M8	16.3	5	14	60	28	31	7x7x55	15.6	15.4
			206	111	230					165						130	200	M10	21.8	6	19							
80	2	1	229	121	240	138	140	80	92	272	174	145	96	75	M10x18	165	130	200	M10	21.7	6	19	65	32	35	10x8x60	20	22
			284	150	295					27.2						8	24											
100	3	2	280	146	270	178	170	100	115	315	225	185	116	85	M12x20	165	130	200	M10	27.1	8	24	75	38	41	10x8x70	37.8	38.4
			284	150	295					215						180	248	M12	31.3	8	28							
120	5	3	333	173	315	198	190	120	155	400	264	220	132	100	M14x28	215	180	248	M12	31.3	8	28	85	45	48	12x8x80	60.2	61.6
			339	173	364					215						180	248	M12	31.3	8	28							
135	7 1/2	5	374	193	339	218	214	135	185	445	306	260	150	110	M16x30	215	180	248	M12	31.3	8	28	95	55	59	15x10x90	81.6	84
			364	193	364					265						230	300	41.3	10	38								

WORM REDUCER E SERIES

蝸輪減速機 E 系列

◆ 安裝方式，依 VOF 系列安裝方向為主 (第 G38 頁)。

Please refer to Page. G38 to confirm the installation.

MODEL : EOV

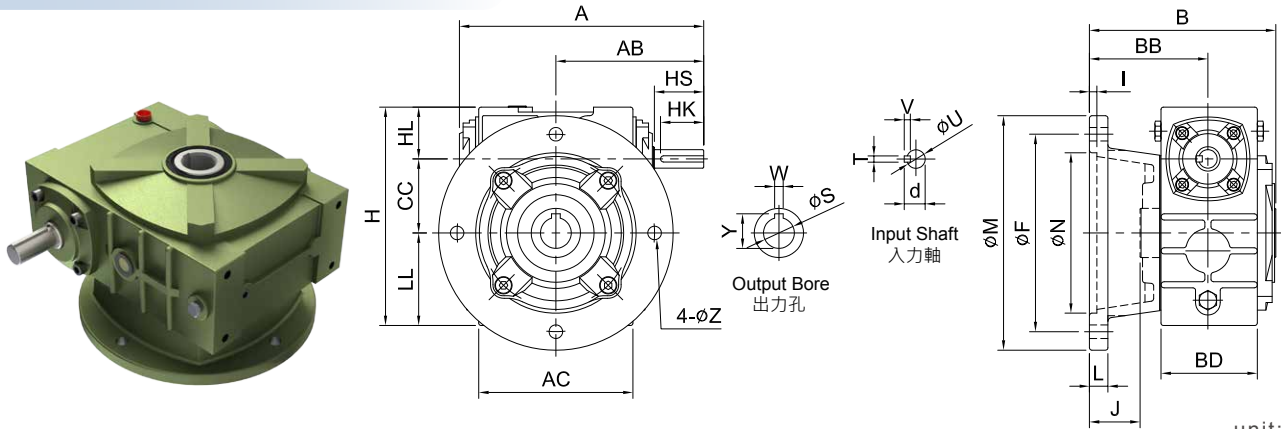

unit: mm

型號 Model	Ratio \ HP		A	AB	AC	B	BB	BD	CC	HL	LL	H	M	F	L	I	J	N	Z	入力軸 Input Shaft				出力孔 Output Bore			重量 Weight (kg)
	1/10 ~ 1/30	1/40 ~ 1/60																		HS	U	d	TxVxHK	W	Y	S	
50	1/4	-	178	105	115	146	96	70	50	35	65	150	180	150	15	6	47	120	11	30	12	13.5	4x4x25	6	22.8	20	9.2
60	1/2	1/4	198	120	124	151	96	77	60	42	75	177	190	160	15	6	42	130	11	40	15	17	5x5x35	8	28.3	25	12.2
70	1	1/2	235	140	154	179	115	85	70	50	85	205	250	215	16	6	51	180	15	40	18	20	5x5x35	8	33.3	30	18.4
80	2	1	268	161	174	184	115	96	80	60	92	232	250	215	16	6	46	180	15	50	22	25	7x7x45	10	38.3	35	24.4
100	3	2	323	190	225	234	145	116	100	75	115	290	300	265	16	5	56	230	15	50	25	28	7x7x45	10	43.3	40	41.6
120	5	3	391	231	264	244	145	132	120	95	155	370	350	300	20	7	46	260	17	65	30	33	7x7x60	12	48.3	45	63
135	7 1/2	5	438	258	306	284	175	150	135	105	185	425	400	350	24	7	66	320	18	75	35	38	10x8x70	15	59.3	55	83

MODEL : EOVM

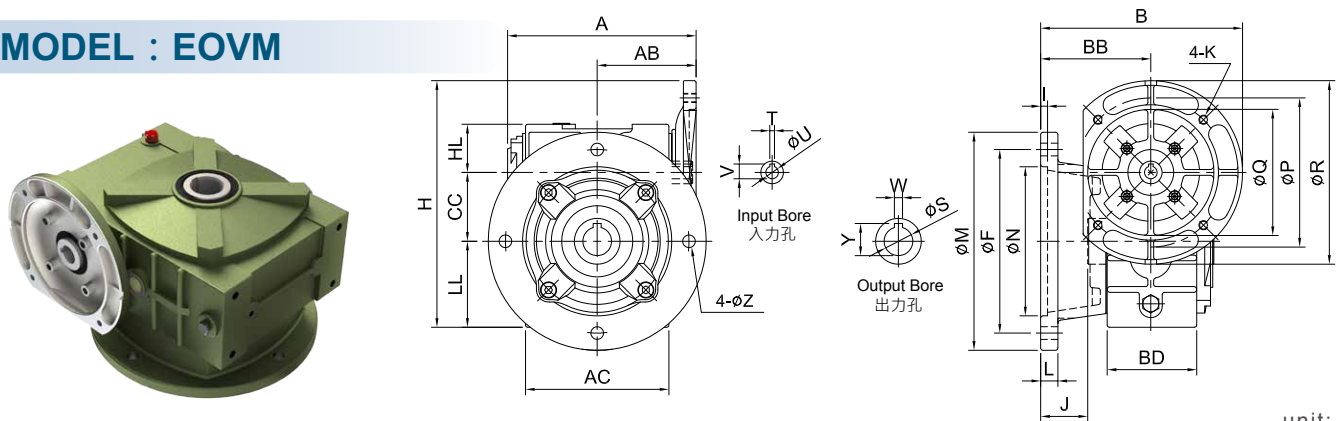

unit: mm

型號 Model	Ratio \ HP		A	AB	AC	B	BB	BD	CC	HL	LL	H	M	F	L	I	J	N	Z	馬達盤 Motor Flange				入力孔 Input Bore			出力孔 Output Bore			重量 Weight (kg)
	1/10 ~ 1/30	1/40 ~ 1/60																		P	Q	R	K	V	T	U	W	Y	S	
50	1/4	-	154	81	115	176	96	70	50	35	65	195	180	150	15	6	47	120	11	130	110	160	M8	12.7	4	11	6	22.8	20	9.6
60	1/2	1/4	165	87	124	176	96	77	60	42	75	215	190	160	15	6	42	130	11	130	110	160	M8	12.7 16.3	4 5	11 14	8	28.3	25	12.4
70	1	1/2	206	105 111	154	195 215	115	85	70	50	85	235 255	250	215	16	6	51	180	15	130 165	110 130	160 200	M8 M10	16.3 21.8	5 6	14 19	8	33.3	30	20
80	2	1	229	121	174	215	115	96	80	60	92	272	250	215	16	6	46	180	15	165	130	200	M10	21.7 27.2	6 8	19 24	10	38.3	35	26
100	3	2	280	146	225	245 270	145	116	100	75	115	315 340	300	265	16	5	56	230	15	165 215	130 180	200 250	M10 M12	27.1 31.3	8	24 28	10	43.3	40	44.6
120	5	3	333	173	264	270	145	132	120	95	155	400	350	300	20	7	46	260	17	215	180	250	M12	31.3	8	28	12	48.3	45	66.6
135	7 1/2	5	374	193	306	300 325	175	150	135	105	185	445 470	400	350	24	7	66	320	18	215 265	180 230	250 300	M12	31.3 41.3	8 10	28 38	15	59.3	55	89

MODEL : LD

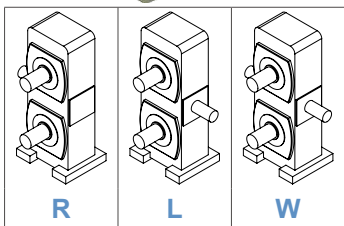

軸向選擇 Shaft Direction

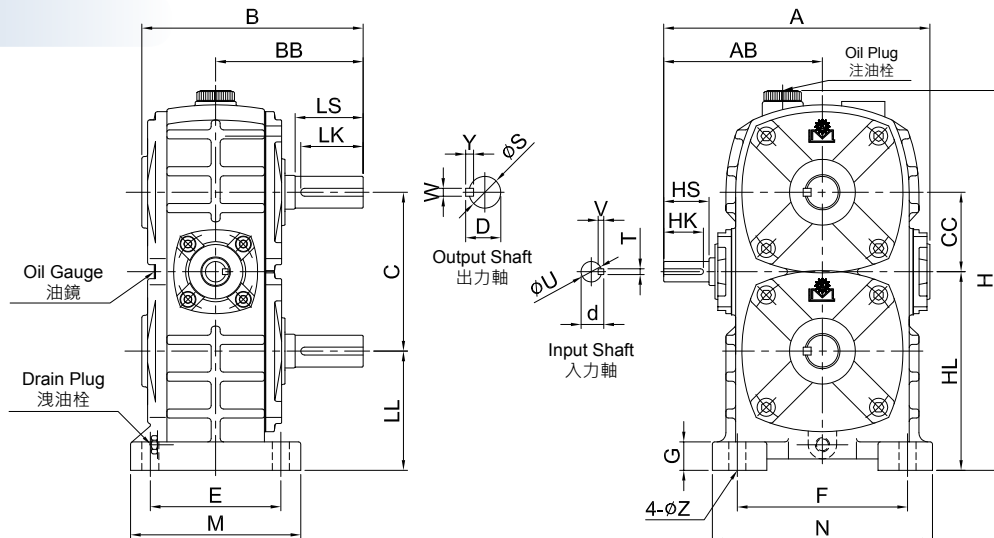

unit: mm

型號 Model	Ratio \ HP		腳座 Foot Stock											入力軸 Input Shaft				出力軸 Output Shaft				重量 Weight (kg)				
	1/10 ~ 1/30	1/40 ~ 1/60	A	AB	B	BB	C	CC	H	HL	LL	E	F	M	N	G	Z	HS	U	d	TxVxHK		LS	S	D	WxYxLK
70	1	1/2	235	140	194	130	140	70	348	175	105	115	150	150	194	25	15	40	18	20	5x5x35	60	28	31	7x7x55	23
80	2	1	268	161	208	140	160	80	378	192	112	135	180	170	220	25	15	50	22	25	7x7x45	65	32	35	10x8x60	30.6
100	3	2	322	190	258	170	200	100	472	250	150	155	220	197	270	27	15	50	25	28	7x7x45	75	38	41	10x8x70	59.4
135	7 1/2	5	435	258	327	214	270	135	636	350	215	200	290	250	350	35	18	75	35	38	10x8x70	95	55	59	15x10x90	135

MODEL : LDM

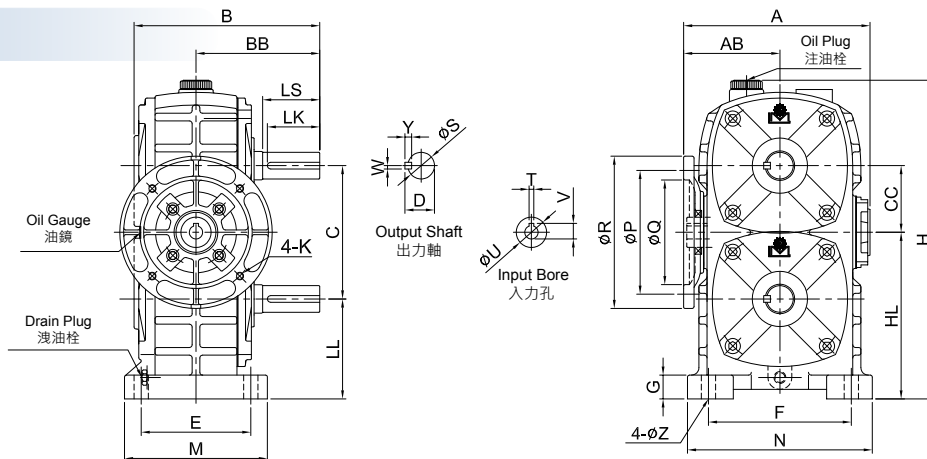

unit: mm

型號 Model	Ratio \ HP		腳座 Foot Stock											入力孔 Input Bore			馬達盤 IEC Motor Flange				出力軸 Output Shaft				重量 Weight (kg)				
	1/10 ~ 1/30	1/40 ~ 1/60	A	AB	B	BB	C	CC	H	HL	LL	E	F	M	N	G	Z	V	T	U	P	Q	R	K		LS	S	D	WxYxLK
70	1	1/2	200	102	108	130	140	70	348	175	105	115	150	150	194	25	15	16.3	5	14	130	110	160	M8	60	28	31	7x7x55	24.6
80	2	1	223	118	208	140	160	80	378	192	112	135	180	170	220	25	15	21.8	6	19	165	130	200	M10	65	32	35	10x8x60	32
100	3	2	278	146	258	170	200	100	472	250	150	155	220	197	270	27	15	27.3	8	24	165	130	200	M10	75	38	41	10x8x70	62.4
135	7 1/2	5	370 371	193 194	327	214	270	135	636	350	215	200	290	250	350	35	18	31.3	8	28	215	180	250	M12	95	55	59	15x10x90	142

WORM REDUCER T SERIES

蝸輪減速機 T 系列

MODEL : TW

R : 右軸 (腳座貼地面, 油鏡端面向自己, 此時輸出端位於右側)

Right Shaft (when facing oil gauge and foot on the ground, output shaft is on the right)

L : 左軸 (腳座貼地面, 油鏡端面向自己, 此時輸出端位於左側)

Left Shaft (when facing oil gauge and foot on the ground, output shaft is on the left)

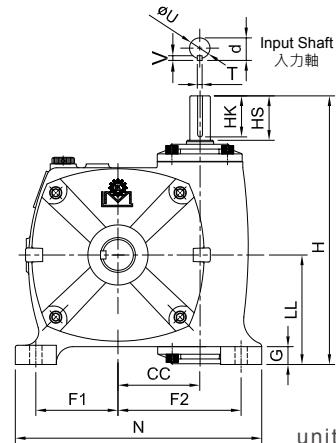
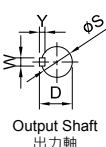
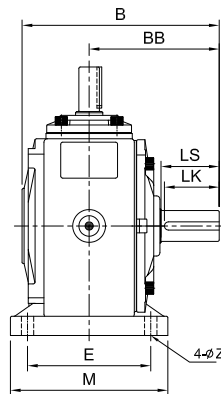
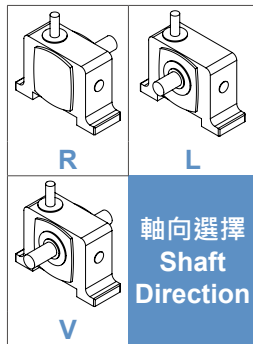

unit: mm

型號 Model	Ratio \ HP		H	LL	CC	B	BB	腳座 Foot Stock						入力軸 Input Shaft				出力軸 Output Shaft				重量 Weight (kg)	
	1/10 ~ 1/30	1/40 ~ 1/60						F1	F2	E	M	N	G	Z	HS	U	d	TxVxHK	LS	S	D		WxYxLK
50	1/4	-	181	76	50	149	98	53	77	100	124	163	16	11	30	12	13.5	4x4x25	40	17	19	5x5x35	7
60	1/2	1/4	210	90	60	165	110	67	98	105	130	200	17	11	40	15	17	5x5x35	50	22	25	7x7x45	9.8
70	1	1/2	236	95	70	189	130	75	115	120	150	230	20	15	40	18	20	5x5x35	60	28	31	7x7x55	13.4
80	2	1	269	105	80	206	140	90	125	125	160	260	20	15	50	22	25	7x7x45	65	32	35	10x8x60	18.4
100	3	2	326	135	100	256	170	100	150	155	195	310	25	15	50	25	28	7x7x45	75	38	41	10x8x70	40.4
120	5	3	392	160	120	286	190	120	180	180	230	360	30	18	65	30	33	7x7x60	85	45	48	12x8x80	57.8
135	7 1/2	5	426	170	135	323	214	130	200	200	250	390	30	18	75	35	38	10x8x70	95	55	59	15x10x90	80

MODEL : TMW

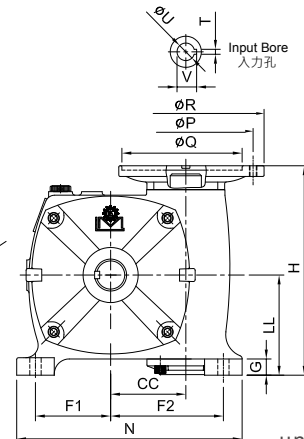
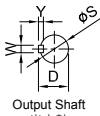
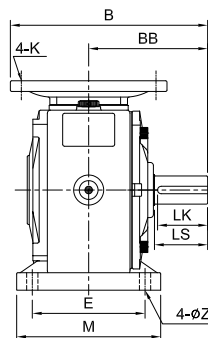
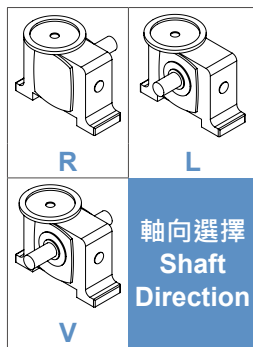

unit: mm

型號 Model	Ratio \ HP		H	LL	CC	B	BB	馬達盤 IEC Motor Flange				腳座 Foot Stock						入力孔 Input Bore			出力軸 Output Shaft				重量 Weight (kg)	
	1/10 ~ 1/30	1/40 ~ 1/60						P	Q	R	K	F1	F2	E	M	N	G	Z	V	T	U	LS	S	D		WxYxLK
50	1/4	-	163	76	50	178	98	130	110	160	M8	53	77	100	124	163	16	11	12.7	4	11	40	17	19	5x5x35	7.8
60	1/2	1/4	177	90	60	190	110	130	110	160	M8	67	98	105	130	200	17	11	12.7	4	11	50	22	25	7x7x45	10.2
70	1	1/2	201	95	70	210	130	130	110	160	M8	75	115	120	150	230	20	15	16.3	5	14	60	28	31	7x7x55	15
																			21.7	6	19					
80	2	1	229	105	80	240	140	165	130	200	M10	90	125	125	160	260	20	15	21.7	6	19	65	32	35	10x8x60	20
																			27.2	8	24					
100	3	2	282	135	100	270	170	165	130	200	M10	100	150	155	195	310	25	15	27.1	8	24	75	38	41	10x8x70	43.4
																			31.3	8	28					
120	5	3	324	160	120	315	190	215	180	248	M12	120	180	180	230	360	30	18	31.3	8	28	85	45	48	12x8x80	60
																			31.3	8	28					
135	7 1/2	5	360	170	135	339	214	215	180	248	M12	130	200	200	250	390	30	18	31.3	8	28	95	55	59	15x10x90	80.4
																			41.3	10	38					

MODEL : TOW

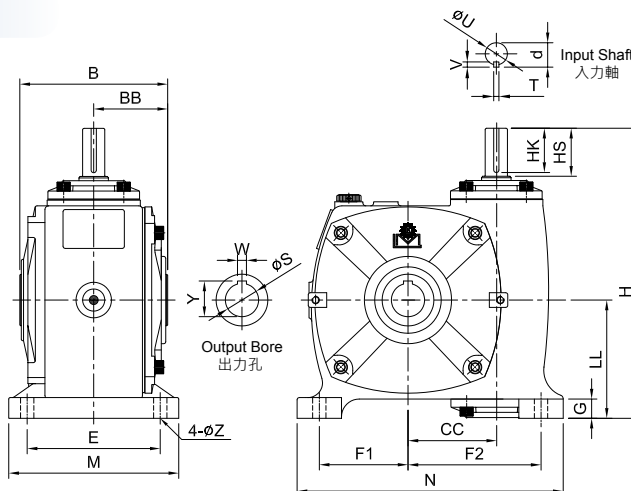

unit: mm

型號 Model	Ratio \ HP		H	LL	CC	BB	B	腳座 Foot Stock						入力軸 Input Shaft				出力孔 Output Bore			重量 Weight (kg)	
	1/10 ~ 1/30	1/40 ~ 1/60						F1	F2	E	M	N	G	Z	HS	U	d	TxVxHK	W	Y		S
60	1/2	1/4	210	90	60	57	108	67	98	105	130	200	17	11	40	15	17	5x5x35	8	28.3	25	
70	1	1/2	236	95	70	64	128	75	115	120	150	230	20	15	40	18	20	5x5x35	8	33.3	30	13.6
80	2	1	269	105	80	69	138	90	125	125	160	260	20	15	50	22	25	7x7x45	10	38.3	35	20
100	3	2	326	135	100	89	178	100	150	155	195	310	25	15	50	25	28	7x7x45	10	43.3	40	41.2
120	5	3	392	160	120	99	198	120	180	180	230	360	30	18	65	30	33	7x7x60	12	48.3	45	57.8
135	7 1/2	5	426	170	135	109	218	130	200	200	250	390	30	18	75	35	38	10x8x70	15	59.3	55	77.8

MODEL : TOM

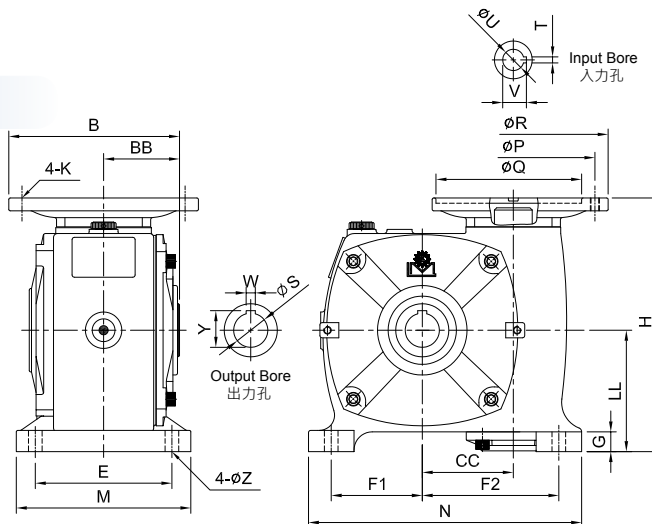

unit: mm

型號 Model	Ratio \ HP		H	LL	CC	BB	B	馬達盤 IEC Motor Flange				腳座 Foot Stock						入力孔 Input Bore			出力孔 Output Bore			重量 Weight (kg)	
	1/10 ~ 1/30	1/40 ~ 1/60						P	Q	R	K	F1	F2	E	M	N	G	Z	V	T	U	W	Y		S
60	1/2	1/4	177	90	60	57	108	130	110	160	M8	67	98	105	130	200	17	11	12.7 16.3	4 5	11 14	8	28.3	25	10.8
70	1	1/2	201 207	95	70	64	128	130 165	110 130	160 200	M8 M10	75	115	120	150	230	20	15	16.3 21.7	5 6	14 19	8	33.3	30	15.2
80	2	1	229	105	80	69	138	165	130	200	M10	90	125	125	160	260	20	15	21.7 27.2	6 8	19 24	10	38.3	35	22.4
100	3	2	282 286	135	100	89	178	165 215	130 180	200 248	M10 M12	100	150	155	195	310	25	15	27.1 31.3	8 8	24 28	10	43.3	40	43.2
120	5	3	326	160	120	100	198	215	180	248	M12	120	180	180	230	360	30	18	31.3	8	28	12	48.3	45	60
135	7 1/2	5	360 361	170	135	109	218	215 265	180 230	248 300	M12	130	200	200	250	390	30	18	31.3 41.3	8 10	28 38	15	59.3	55	78.4

WORM REDUCER VOF SERIES

蝸輪減速機 VOF 系列

MODEL : VOF

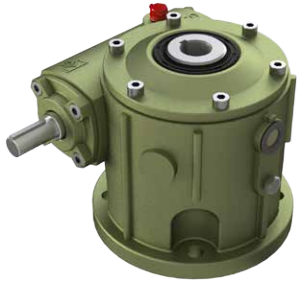

▲ 70#~100#

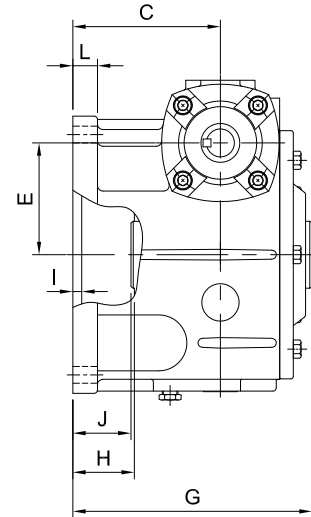
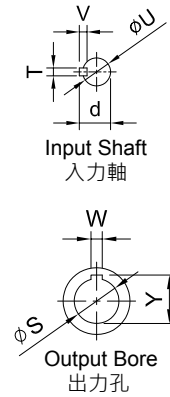
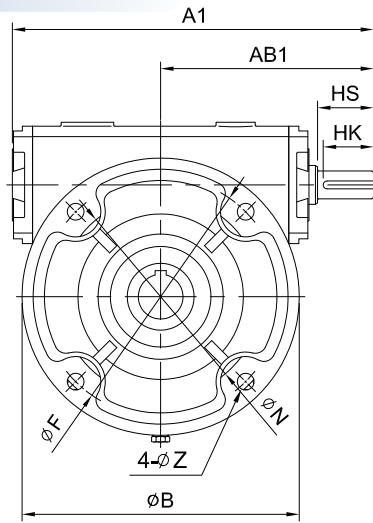

unit: mm

型號 Model	Ratio \ HP		A1	AB1	B	C	N	E	F	G	H	I	J	L	Z	入力軸 Input Shaft				出力孔 Output Bore			重量 Weight (kg)
	1/10 ~ 1/30	1/40 ~ 1/60														HS	U	d	TxVxHK	W	Y	S	
	70	1														1/2	235	140	182	106	115	70	
80	2	1	268	161	200	107	130	80	170	180	34	12	30	20	15	50	22	25	7x7x45	10	38.3	35	19.4
100	3	2	323	190	248	132	180	100	215	214	55	14	52	22	15	50	25	28	7x7x45	10	43.3	40	35

MODEL : VOF



▲ 120#~135#

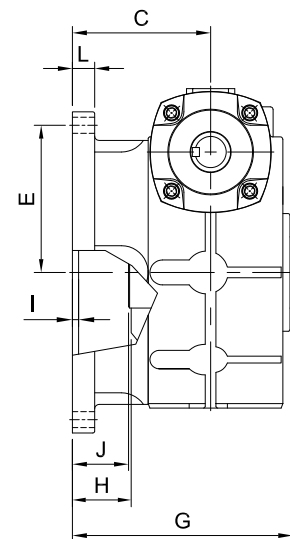
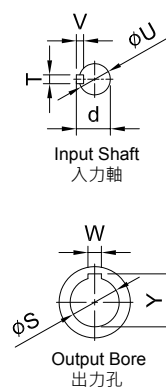
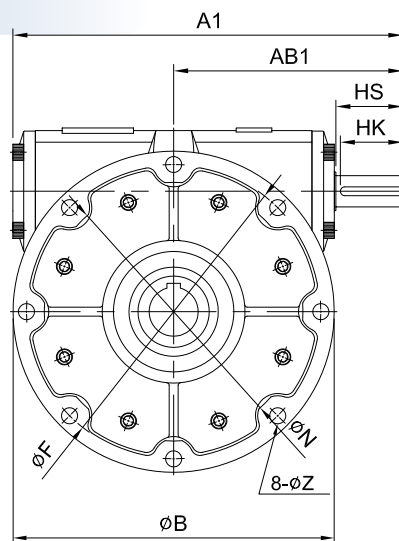

unit: mm

型號 Model	Ratio \ HP		A1	AB1	B	C	N	E	F	G	H	I	J	L	Z	入力軸 Input Shaft				出力孔 Output Bore			重量 Weight (kg)
	1/10 ~ 1/30	1/40 ~ 1/60														HS	U	d	TxVxHK	W	Y	S	
	120	5														3	391	231	330	145	260	120	
135	7 1/2	5	438	258	360	155	290	135	330	247	66	7	63	25	18	75	35	38	10x8x70	15	59.3	55	84.6

MODEL : VOFM



▲ 70#~100#

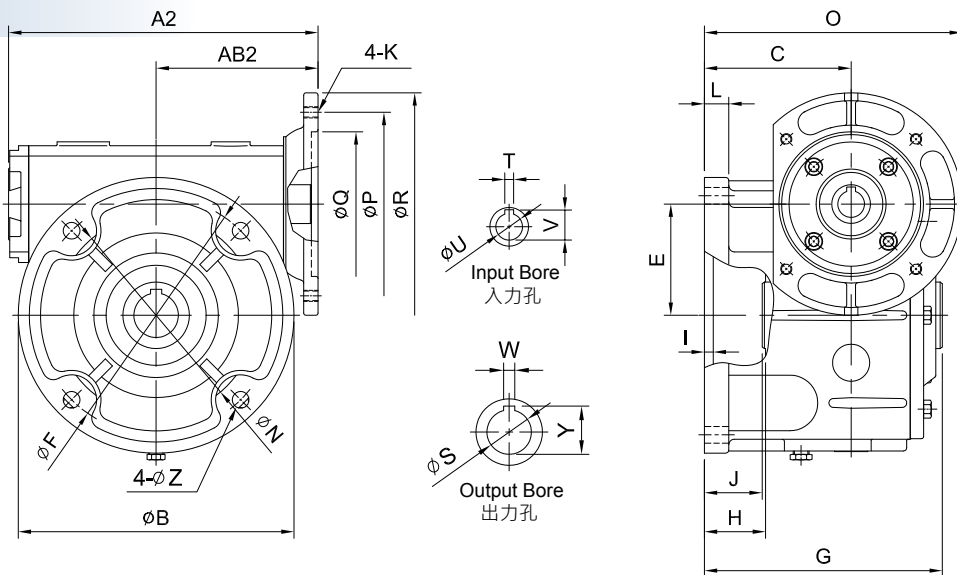

unit: mm

型號 Model	Ratio \ HP		A2	AB2	B	C	N	E	F	G	H	I	J	L	O	Z	馬達盤 IEC Motor Flange				入力孔 Input Bore			出力孔 Output Bore			重量 Weight (kg)
	1/10 ~ 1/30	1/40 ~ 1/60															P	Q	R	K	V	T	U	W	Y	S	
70	1	1/2	200 206	105 111	182	106	115	70	150	170	45	9	42	17	186 206	15	130 165	110 130	160 200	M8 M10	16.3 21.8 27.3	5 6 8	14 19 24	7 10	28.3 38.3	25 35	15.4 21
100	3	2	279 284	146 150	248	132	180	100	215	214	55	14	52	22	232 257	15	165 215	130 180	200 248	M10 M12	27.3 31.3	8	24 28	10	43.3	40	38

MODEL : VOFM



▲ 120#~135#

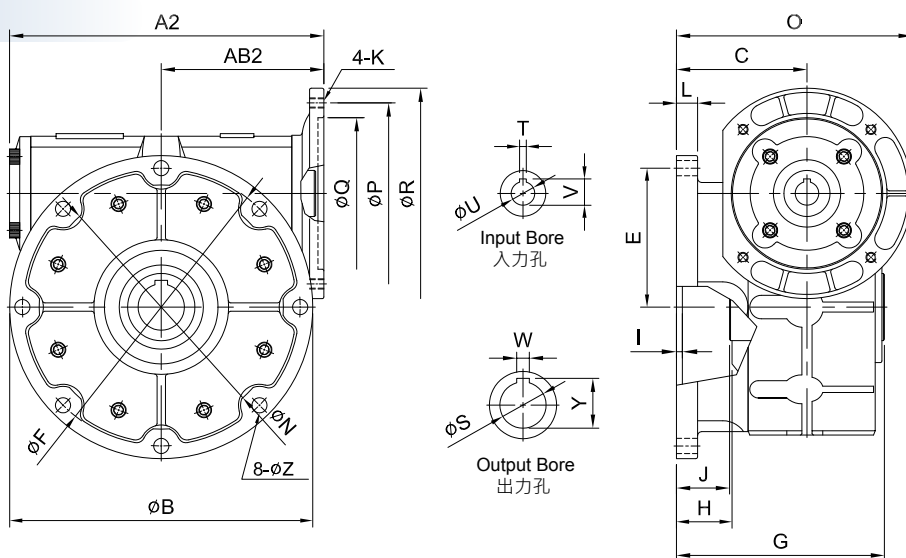

unit: mm

型號 Model	Ratio \ HP		A2	AB2	B	C	N	E	F	G	H	I	J	L	O	Z	馬達盤 IEC Motor Flange				入力孔 Input Bore			出力孔 Output Bore			重量 Weight (kg)
	1/10 ~ 1/30	1/40 ~ 1/60															P	Q	R	K	V	T	U	W	Y	S	
120	5	3	334	173	330	145	260	120	300	234	61	6	56	24	270	18	215	180	248	M12	31.3	8	28	12	53.3	50	56.4
135	7 1/2	5	374 375	193 194	360	155	290	135	330	247	66	7	63	25	280 305	18	215 265	180 230	248 300	M12	31.3 41.3	8 10	28 38	15	59.3	55	85

■ 安裝方向 Installation Direction (EOV、EOVM、VOF、VOFM)

● 油面計
Oil Indicator

▼ 注油栓
Oil Plug

⚠ 排油栓
Oil Drain Plug

◆ 正常的使用方向可以使減速機保持較高的壽命。
The life time of gear reducer can be prolonged in proper direction.

◆ 安裝時請注意油面計、注油栓及排油栓的位置以便日後維護。
Please note the positions of oil gauge, oil filling plug and oil drain plug to facilitate the maintenance afterwards.

◆ 減速機使用方向特殊時，請與我們連繫。
For special installation direction, please contact us.

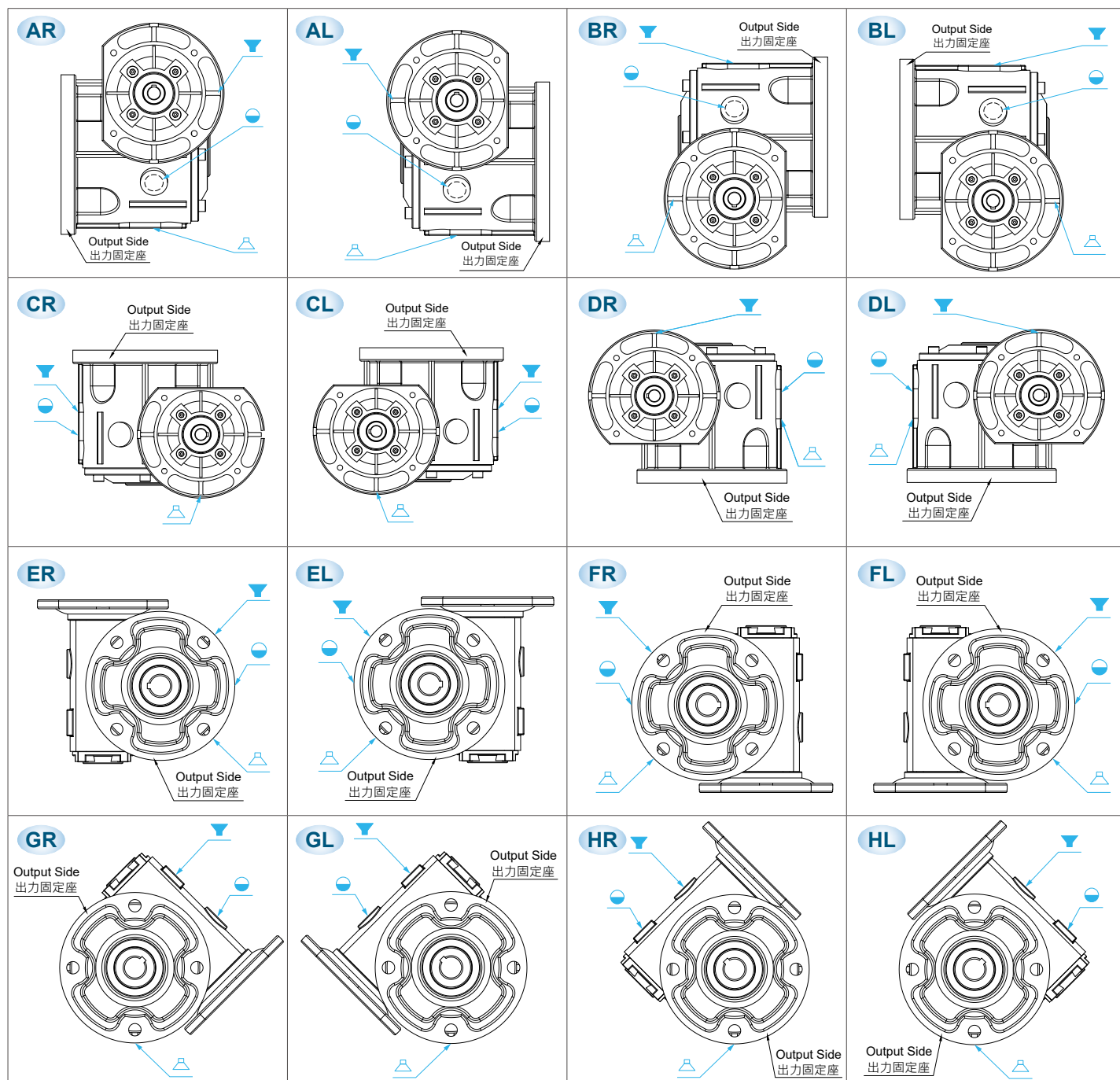

2-STAGE WORM REDUCER (WORM+WORM) SERIES

雙段蝸輪減速機 (蝸輪 + 蝸輪) 系列

■ 蝸輪 + 蝸輪系列 Worm + Worm Series

◆ 特點 Features :

1. 減速比多變化
Various reduction ratios.
2. 適合低速高扭力矩之轉動
Suitable for low-speed and high-torque transmission.
3. 可選擇組合角度
Various assembling angles for choice.

◆ 型號 Model :

60#~175#

◆ 馬力 HP :

1/16HP~5HP

◆ 減速比 Ratio :

1/100, 1/150, 1/200, 1/300, 1/400, 1/500,
1/600, 1/800, 1/900, 1/1000, 1/1200,
1/1500, 1/1600, 1/1800, 1/2000, 1/2400,
1/2500, 1/3000, 1/3600

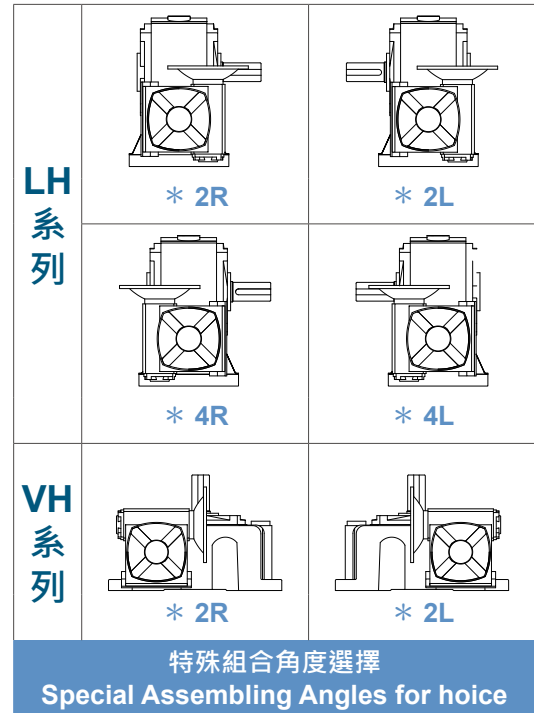

*記號者為特殊品 * means special product
*適用機型 100#~175# * Model: 100#~175#

油量表 Oil Capacities (unit: ℓ)

Type Model	LH	LHM	LOH	LOHM	VH UH	VHM UHM	VOH	VOHM	EH	EHM	EOH	EOHM
60	0.5	-	0.5	-	0.6	-	0.6	-	0.5	-	0.5	-
70	0.8	-	0.8	-	1	-	1	-	0.8	-	0.8	-
80	1.0	1.0	1.0	1.0	1.6	1.6	1.6	1.6	1	1	1	1
100	1.8	1.8	1.8	1.8	2.9	2.9	2.9	2.9	1.8	1.8	1.8	1.8
120	2.8	2.8	2.8	2.8	4.6	4.6	4.6	4.6	2.8	2.8	2.8	2.8
135	4.6	4.6	4.6	4.6	7.1	7.1	7.1	7.1	4.6	4.6	4.6	4.6
155	7	7	7	7	8.6	8.6	8.6	8.6	-	-	-	-
175	9	9	9	9	12	12	12	12	-	-	-	-

出力段減速機中心距離 (mm) Central distance of output of reducer.	C1	60	70	80	100	120	135	155	175
入力段減速機中心距離 (mm) Central distance of input of reducer.	C2	32	40	50	60	70	80	100	120

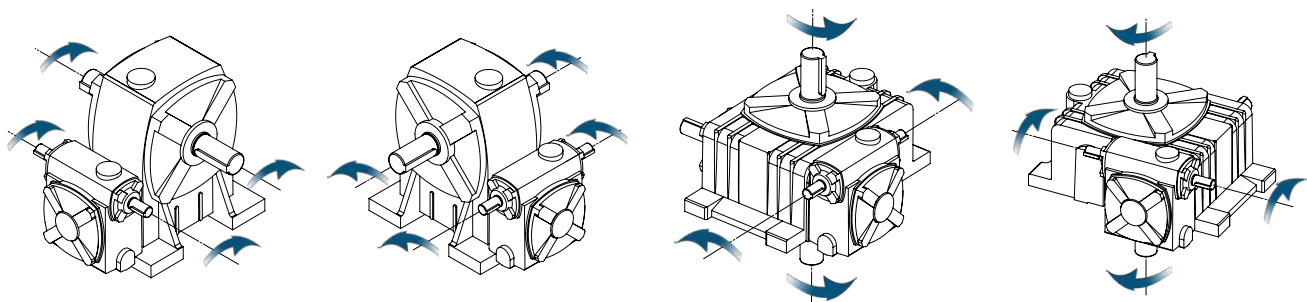

旋轉方向
Rotation Directions

分解系統圖 System Drawing

MODEL : LH

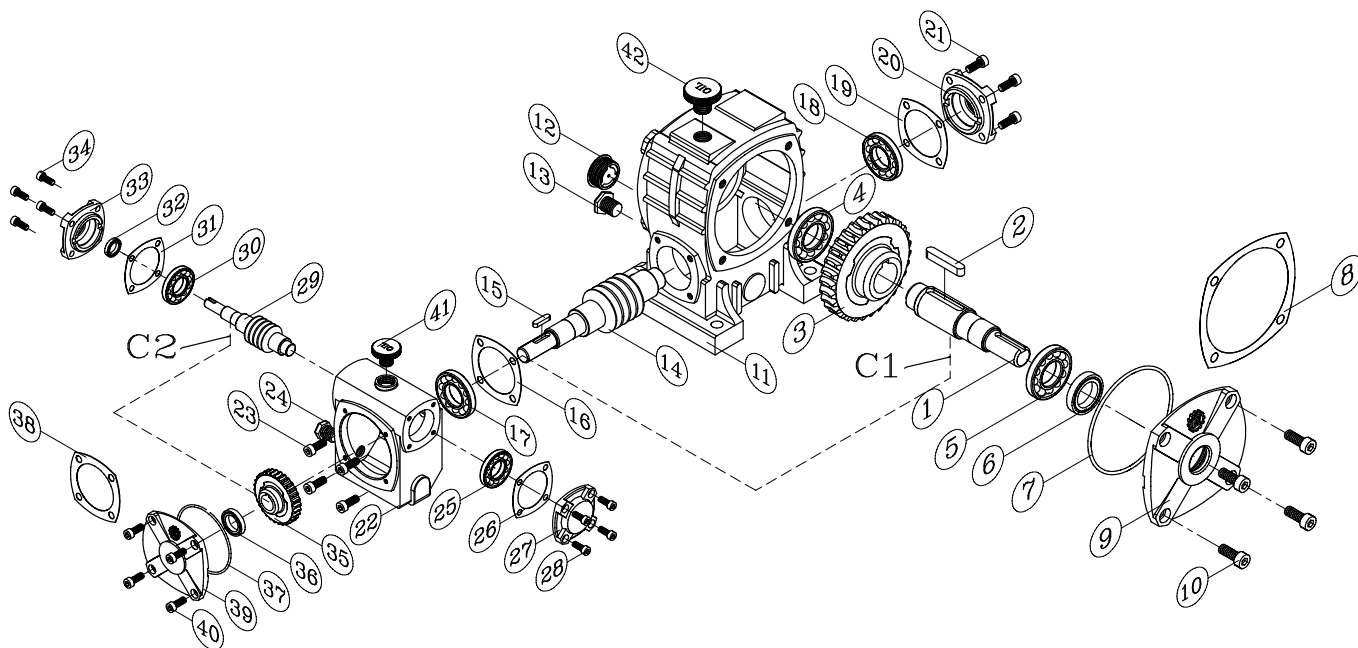

NO.	零件名稱	Name of Parts	NO.	零件名稱	Name of Parts
1	出力軸	Output Shaft	24	排油栓	Drain Plug
2	雙圓鍵	Key	25	滾錐軸承 120# 以上	Taper Roller Bearing for Model 120# above
3	蝸輪	Worm Wheel	26	非石棉墊片	Asbestos Free Gasket
4	滾珠軸承	Ball Bearing	27	入力軸蓋	Input Shaft Cover
5	滾珠軸承	Ball Bearing	28	六角承窩頭螺絲	Hex Screw
6	油封	Oil Seal	29	蝸桿 (入力軸)	Worm Shaft (Input Shaft)
7	O 型環	O Ring	30	滾錐軸承 120# 以上	Taper Roller Bearing for Model 120# above
8	非石棉墊片	Asbestos Free Gasket	31	非石棉墊片	Asbestos Free Gasket
9	出力軸蓋 (有孔)	Output Shaft Cover (with bore)	32	油封	Oil Seal
10	六角承窩頭螺絲	Hex Screw	33	入力軸蓋 (有孔)	Input Shaft Cover (with bore)
11	蝸輪箱	Outer Shell	34	六角承窩頭螺絲	Hex Screw
12	油鏡	Oil Gauge	35	蝸輪	Worm Wheel
13	排油栓	Drain Plug	36	滾珠軸承	Ball Bearing
14	蝸桿 (入力軸)	Worm Shaft (Input Shaft)	37	O 型環	O Ring
15	雙圓鍵	Key	38	非石棉墊片	Asbestos Free Gasket
16	非石棉墊片	Asbestos Free Gasket	39	出力軸蓋	Output Shaft Cover
17	滾錐軸承	Taper Roller Bearing	40	六角承窩頭螺絲	Hex Screw
18	滾錐軸承	Taper Roller Bearing	41	油栓	Oil Plug
19	非石棉墊片	Asbestos Free Gasket	42	注油栓	Oil Plug
20	入力軸蓋	Input Shaft Cover	17, 18	60# 以下滾珠軸承	Ball Bearing for 60# below
21	六角承窩頭螺絲	Hex Screw	8, 38	100# (含) 以上不使用 非石棉墊片	Model 100# and above are without Asbestos Free Gasket
22	蝸輪箱	Outer Shell	36	80# 以下不用滾珠軸承	Model 80# below are without Ball Bearing
23	六角承窩頭螺絲	Hex Screw			

2-STAGE WORM REDUCER (WORM+WORM) SERIES

雙段蝸輪減速機 (蝸輪 + 蝸輪) 系列

分解系統圖 System Drawing

MODEL : LHM

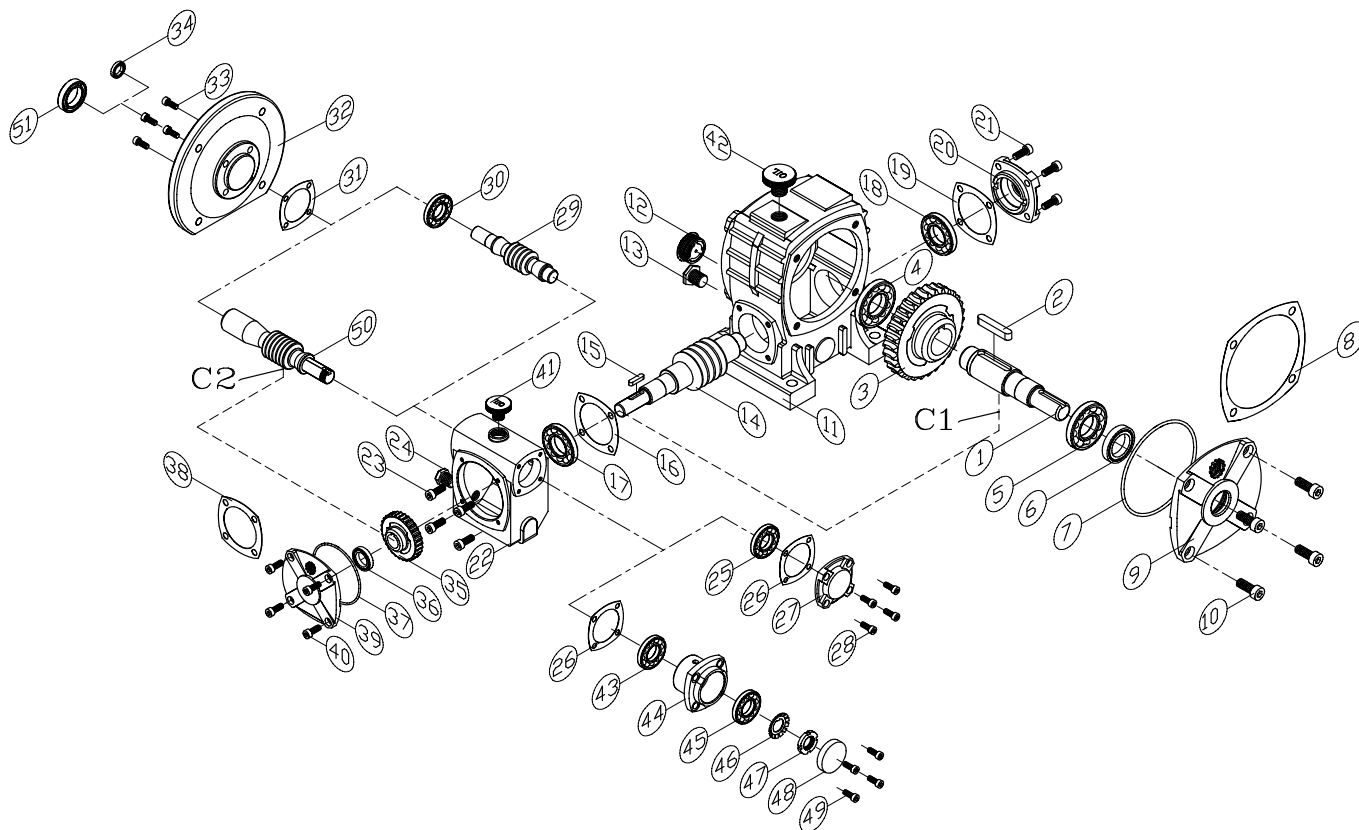

NO.	零件名稱	Name of Parts
1	出力軸	Output Shaft
2	雙圓鍵	Key
3	蝸輪	Worm Wheel
4	滾珠軸承	Ball Bearing
5	滾珠軸承	Ball Bearing
6	油封	Oil Seal
7	O 型環	O Ring
8	非石棉墊片	Asbestos Free Gasket
9	出力軸蓋 (有孔)	Output Shaft Cover (with bore)
10	六角承窩頭螺絲	Hex Screw
11	蝸輪箱	Outer Shell
12	油鏡	Oil Gauge
13	排油栓	Drain Plug
14	蝸桿 (入力軸)	Worm Shaft (Input Shaft)
15	雙圓鍵	Key
16	非石棉墊片	Asbestos Free Gasket
17	滾錐軸承	Taper Roller Bearing
18	滾錐軸承	Taper Roller Bearing
19	非石棉墊片	Asbestos Free Gasket
20	入力軸蓋	Input Shaft Cover
21	六角承窩頭螺絲	Hex Screw
22	蝸輪箱	Outer Shell
23	六角承窩頭螺絲	Hex Screw
24	排油栓	Drain Plug
25	滾錐軸承或滾珠軸承	Taper Roller Bearing or Ball Bearing
26	非石棉墊片	Asbestos Free Gasket
27	入力軸蓋	Input Shaft Cover

NO.	零件名稱	Name of Parts
28	六角承窩頭螺絲	Hex Screw
29	蝸桿 (入力軸)	Worm Shaft (Input Shaft)
30	滾錐軸承或滾珠軸承	Taper Roller Bearing or Ball Bearing
31	非石棉墊片	Asbestos Free Gasket
32	馬達盤	Motor Cover
33	六角承窩頭螺絲	Hex Screw
34	油封	Oil Seal
35	蝸輪	Worm Wheel
36	滾珠軸承	Ball Bearing
37	O 型環	O Ring
38	非石棉墊片	Asbestos Free Gasket
39	出力軸蓋	Output Shaft Cover
40	六角承窩頭螺絲	Hex Screw
41	油栓	Oil Plug
42	注油栓	Oil Plug
43	滾錐軸承	Taper Roller Bearing
44	入力後蓋	Input Shaft Cover
45	滾錐軸承	Taper Roller Bearing
46	太陽片	Lock Washers AW
47	軸承螺帽	Lock Nuts AN
48	密油封	Oil Seal
49	六角承窩頭螺絲	Hex Screw
50	蝸桿	Worm Shaft
51	油封	Oil Seal
17, 18	60# 以下滾珠軸承	Ball Bearing for Model 60# below
8, 38	100#(含) 以上不使用非石棉墊片	Model 100# and above are without Asbestos Free Gasket
36	80# 以下不用滾珠軸承	Model 80# below are without Ball Bearing

MODEL : LH

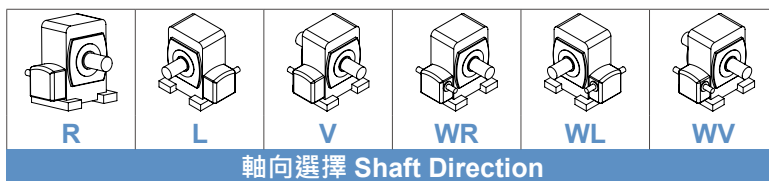

軸向選擇 Shaft Direction

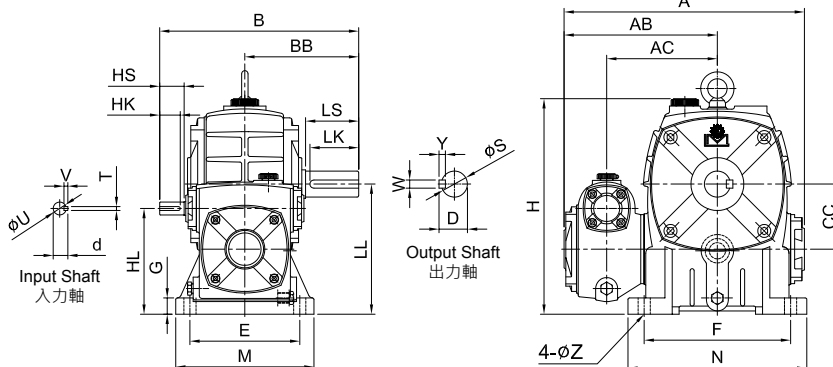

unit: mm

型號 Model	Ratio \ HP		A	AB	AC	B	BB	CC	H	HL	LL	腳座 Foot Stock				入力軸 Input Shaft				出力軸 Output Shaft				重量 Weight (kg)		
	1/100 ~ 1/900	1/1000 ~ 1/3600										E	F	M	N	G	Z	HS	U	d	TxVxHK	LS	S		D	WxYxLK
60	1/16	-	222	144	100	198	110	60	200	92	120	105	120	130	150	20	11	38	12	13.5	4x4x25	50	22	25	7x7x45	11.8
70	1/8	-	260	165	121	216	130	70	240	110	140	115	150	150	190	20	15	25	12	13.5	4x4x20	60	28	31	7x7x55	16.4
80	1/4	-	295	188	136	245	140	80	266	130	160	135	180	170	214	20	15	30	12	13.5	4x4x25	65	32	35	10x8x60	24
100	1/2	1/4	346	214	158	290	170	100	331	160	200	155	220	195	270	25	15	40	15	17	5x5x35	75	38	41	10x8x70	42.6
120	1	1/2	407	248	185	330	190	120	398	190	240	180	260	230	310	30	18	40	18	20	5x5x35	85	45	48	12x8x80	70.6
135	2	1	471	290	219	375	214	135	440	215	270	200	290	250	340	32	18	50	22	25	7x7x45	95	55	59	15x10x90	96.6
155	3	2	547	348	258	443	253	155	490	235	290	220	320	285	380	38	20	50	25	28	7x7x45	110	60	64	15x10x105	118
175	5	3	623	393	284	493	262	175	565	280	335	250	350	315	415	40	22	65	30	33	7x7x60	110	65	69	18x10x105	196.2

MODEL : LHM

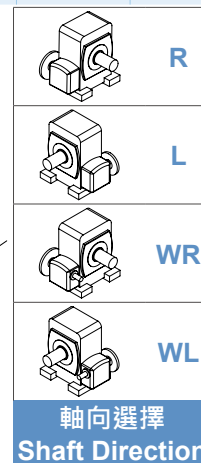
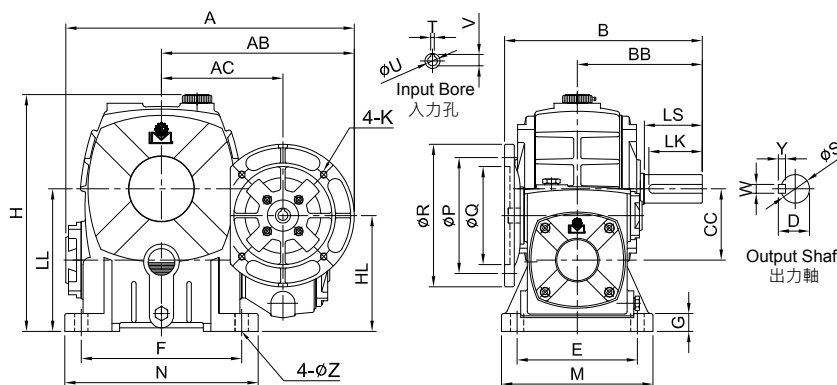

軸向選擇 Shaft Direction

unit: mm

型號 Model	Ratio \ HP		A	AB	AC	B	BB	CC	H	HL	LL	馬達盤 IEC Motor Flange				腳座 Foot Stock				入力孔 Input Bore			出力軸 Output Shaft				重量 Weight (kg)		
	1/100 ~ 1/900	1/1000 ~ 1/3600										P	Q	R	K	E	F	M	N	G	Z	V	T	U	LS	S		D	WxYxLK
80	1/4	-	324	216	136	221	140	80	260	130	160	130	110	160	M8	135	180	170	214	20	15	12.7	4	11	65	32	35	10x8x60	25.6
100	1/2	1/4	371	238	158	256	170	100	337	160	200	130	110	160	M8	155	220	195	270	25	15	12.7	4	11	75	38	41	10x8x70	45.6
120	1	1/2	424	265	185	291	190	120	398	190	240	130	110	160	M8	180	260	230	310	30	18	16.3	5	14	85	45	48	12x8x80	72
135	2	1	500	319	219	330	214	135	440	215	270	165	130	200	M10	200	290	250	340	32	18	16.3	5	14	95	55	59	15x10x90	97.8
155	3	2	557	358	258	397	253	155	490	235	290	165	130	200	M10	220	320	285	380	38	20	21.8	6	19	110	60	64	15x10x105	122
175	5	3	645	415	284	435	262	175	565	280	335	215	180	248	M12	250	350	315	415	40	22	27.3	8	24	110	65	69	18x10x105	199.6

2-STAGE WORM REDUCER (WORM+WORM) SERIES

雙段蝸輪減速機 (蝸輪 + 蝸輪) 系列

MODEL : LOH

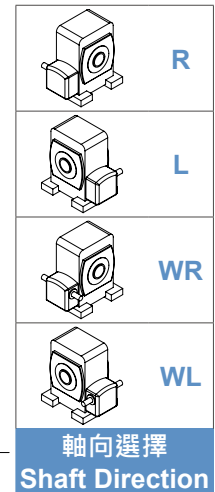
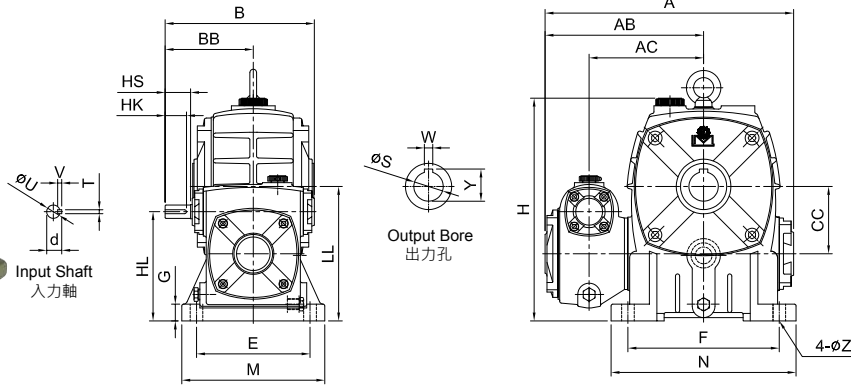

unit: mm

型號 Model	Ratio \ HP		腳座 Foot Stock										輸入軸 Input Shaft				出力孔 Output Bore			重量 Weight (kg)					
	1/100 ~ 1/900	1/1000 ~ 1/3600	A	AB	AC	B	BB	CC	H	HL	LL	E	F	M	N	G	Z	HS	U		d	TxVxHK	W	Y	S
60	1/16	-	222	144	100	144	88	60	200	92	120	105	120	130	150	20	11	38	12	13.5	4x4x25	8	28.3	25	13
70	1/8	-	260	165	121	151	86	70	240	110	140	115	150	150	190	20	15	25	12	13.5	4x4x20	8	33.3	30	19.2
80	1/4	-	295	188	136	175	105	80	266	130	160	135	180	170	214	20	15	30	12	13.5	4x4x25	10	38.3	35	26
100	1/2	1/4	346	214	158	210	120	100	337	160	200	155	220	195	270	25	15	40	15	17	5x5x35	10	43.3	40	43.4
120	1	1/2	407	248	185	240	140	120	398	190	240	180	260	230	310	30	18	40	18	20	5x5x35	12	48.3	45	72.6
135	2	1	471	290	219	271	161	135	440	215	270	200	290	250	340	32	18	50	22	25	7x7x45	15	59.3	55	90.6
155	3	2	547	348	258	313.5	190	155	490	235	290	220	320	285	380	38	20	50	25	28	7x7x45	15	69.3	65	113.2
175	5	3	623	393	284	362	231	175	556	280	335	250	350	315	415	40	22	65	30	33	7x7x60	18	94.3	90	200

MODEL : LOHM

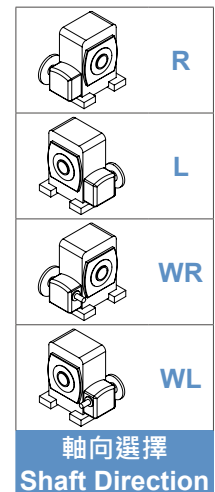
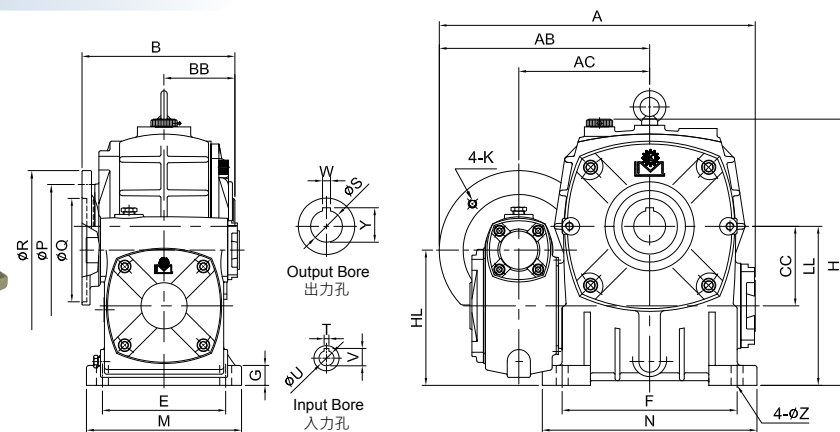

unit: mm

型號 Model	Ratio \ HP		馬達盤 IEC Motor Flange										腳座 Foot Stock					輸入孔 Input Bore			出力孔 Output Bore			重量 Weight (kg)				
	1/100 ~ 1/900	1/1000 ~ 1/3600	A	AB	AC	B	BB	CC	H	HL	LL	P	Q	R	K	E	F	M	N	G	Z	V	T		U	W	Y	S
80	1/4	-	324	216	136	151	70	80	266	130	160	130	110	160	M8	135	180	170	214	20	15	12.7	4	11	10	38.3	35	27.4
100	1/2	1/4	371	238	158	176	90	100	337	160	200	130	110	160	M8	155	220	195	270	25	15	12.7	4	11	10	43.3	40	46.4
120	1	1/2	424	265	185	202	100	120	398	190	240	130	110	160	M8	180	260	230	310	30	18	16.3	5	14	12	48.3	45	73
135	2	1	500	319	219	226	110	135	440	215	270	165	130	200	M10	200	290	250	340	32	18	16.3	5	14	15	59.3	55	91.8
155	3	2	557	358	258	267.5	123.5	155	490	235	290	165	130	200	M10	220	320	285	380	38	20	16.3	5	14	15	69.3	65	117.2
175	5	3	645	415	284	295	131	175	556	280	335	215	180	248	M12	250	350	315	415	40	22	21.8	6	19	18	94.3	90	203.4

MODEL : VH

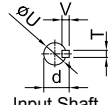

Input Shaft
入力軸

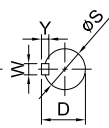
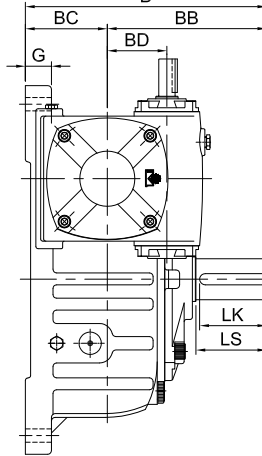

Output Shaft
出力軸

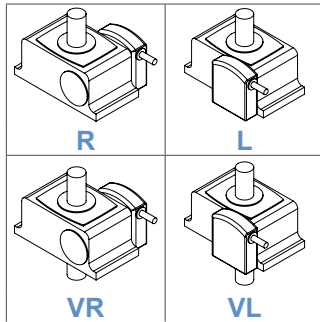
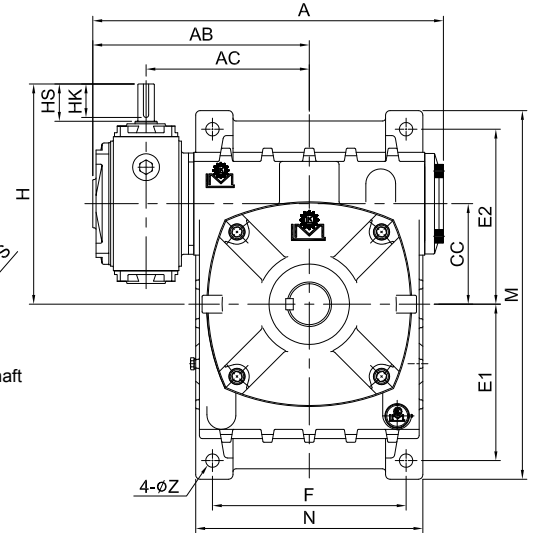

軸向選擇 Shaft Direction

MODEL : UH

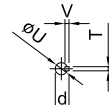

Input Shaft
入力軸

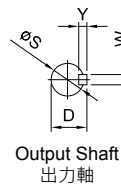
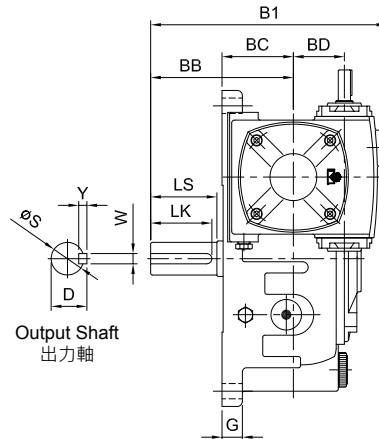

Output Shaft
出力軸

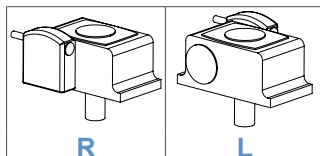
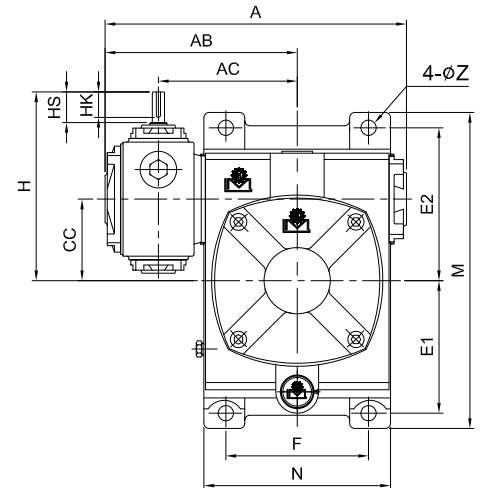

軸向選擇 Shaft Direction

unit: mm

型號 Model	Ratio \ HP		A	AB	AC	B	B1	BB	BC	BD	CC	H	腳座 Foot Stock						入力軸 Input Shaft				出力軸 Output Shaft				重量 Weight (kg)	
	1/100	1/1000											E1	E2	F	M	N	G	Z	HS	U	d	TxVxHK	LS	S	D		WxYxLK
	~ 1/900	1/3600																										
60	1/16	-	218	140	100	165	175	110	55	32	60	148	105	120	100	252	128	18	11	25	12	13.5	4x4x25	50	22	25	7x7x45	12
70	1/8	-	260	165	121	195	207	130	65	40	70	156	120	135	120	288	160	20	15	25	12	13.5	4x4x20	60	28	31	7x7x55	17.4
80	1/4	-	295	188	136	210	231	140	70	50	80	185	130	150	140	315	183	20	15	30	12	13.5	4x4x25	65	32	35	10x8x60	24.4
100	1/2	1/4	346	214	158	260	280	170	90	60	100	220	155	180	190	380	230	30	15	40	15	17	5x5x35	75	38	41	10x8x70	38.2
120	1	1/2	407	248	185	290	315	190	100	70	120	260	185	215	220	450	266	30	18	40	18	20	5x5x35	85	45	48	12x8x80	73.6
135	2	1	472	292	219	324	352	214	110	80	135	296	210	235	260	495	305	35	18	50	22	25	7x7x45	95	55	59	15x10x90	97.4
155	3	2	547	348	258	393	419	253	140	100	155	345	145	265	290	460	340	45	20	50	25	28	7x7x45	110	60	64	15x10x105	120.4
175	5	3	616	386	284	412	451	262	150	120	175	406	167	293	320	516	385	45	22	65	30	33	7x7x60	110	65	69	18x10x105	187

2-STAGE WORM REDUCER (WORM+WORM) SERIES

雙段蝸輪減速機 (蝸輪 + 蝸輪) 系列

MODEL : VHM

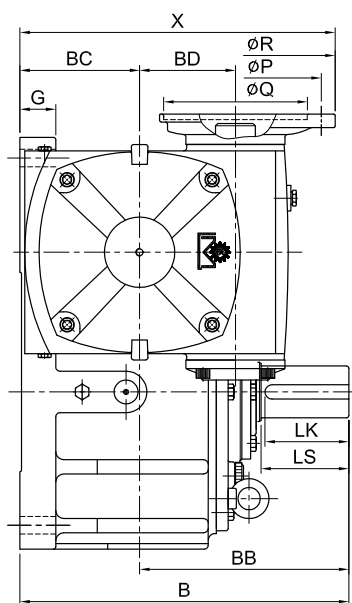
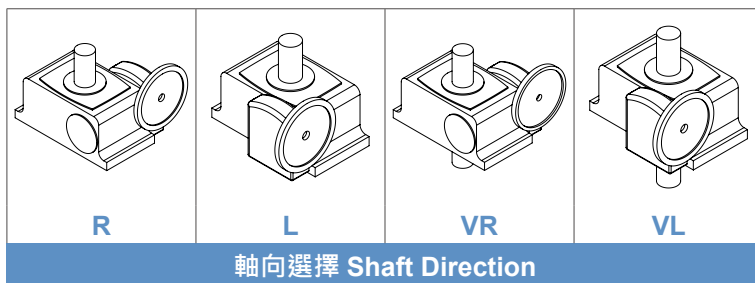
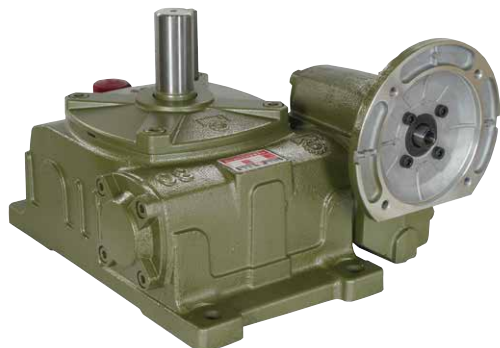

VHM155~175

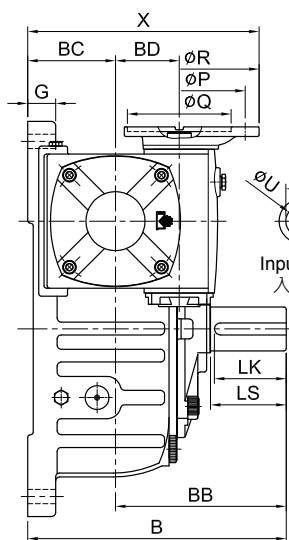

VHM80~135

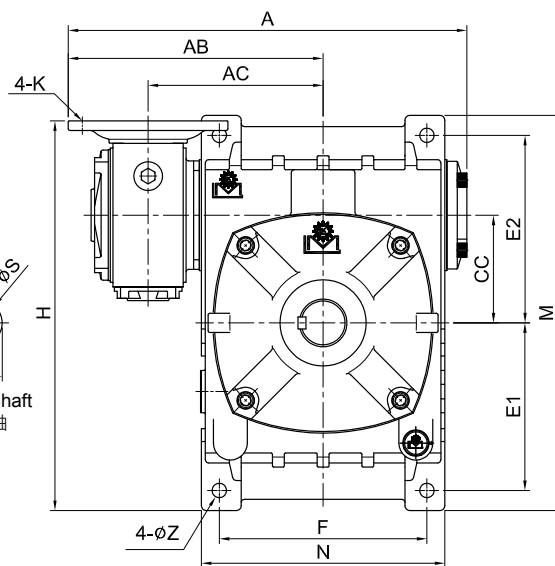

unit: mm

型號 Model	Ratio \ HP		馬達盤 IEC Motor Flange											腳座 Foot Stock					入力孔 Input Bore			出力軸 Output Shaft				重量 Weight (kg)					
	1/100 ~ 1/900	1/1000 ~ 1/3600	A	AB	AC	B	X	BB	BC	BD	CC	H	P	Q	R	K	E1	E2	F	M	N	G	Z	V	T		U	LS	S	D	WxYxLK
80	1/4	-	323	216	136	210	200	140	70	50	80	310	130	110	160	M8	130	150	140	315	183	20	15	12.7	4	11	65	32	35	10x8x60	25.4
100	1/2	1/4	370	238	158	260	230	170	90	60	100	365	130	110	160	M8	155	180	190	380	230	30	15	12.7	4	11	75	38	41	10x8x70	41.2
120	1	1/2	425	265	185	290	250	190	100	70	120	432	130	110	160	M8	185	215	220	450	266	30	18	16.3	5	14	85	45	48	12x8x80	74.8
135	2	1	499	319	219	324	290	214	110	80	135	490	165	130	200	M10	210	235	260	495	305	35	18	21.8	6	19	95	55	59	15x10x90	98.6
155	3	2	557	358	258	393	340	253	140	100	155	471	165	130	200	M10	145	265	290	460	340	45	20	27.3	8	24	110	60	64	15x10x105	124.4
175	5	3	638	408	284	412	395	262	150	120	175	530	215	180	248	M12	167	293	320	516	385	45	20	31.3	8	28	110	65	69	18x10x105	190.4

MODEL : UHM

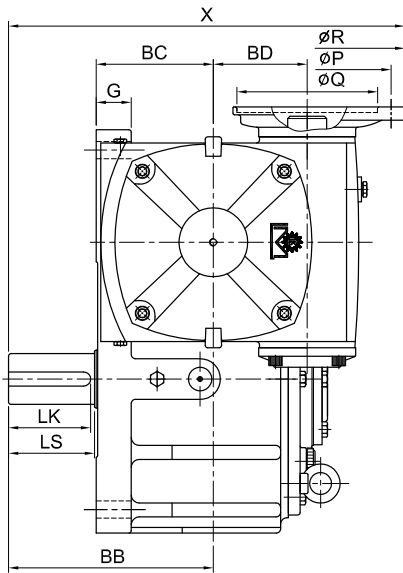
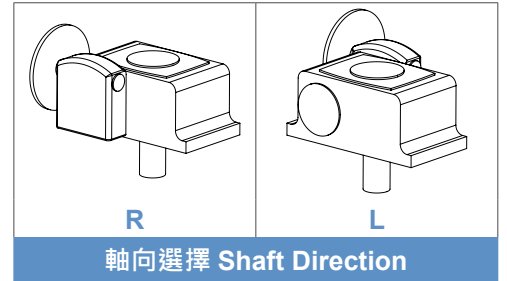

UHM155~175

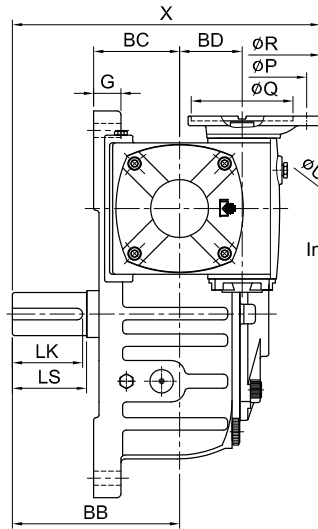

UHM80~135

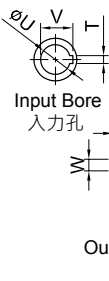
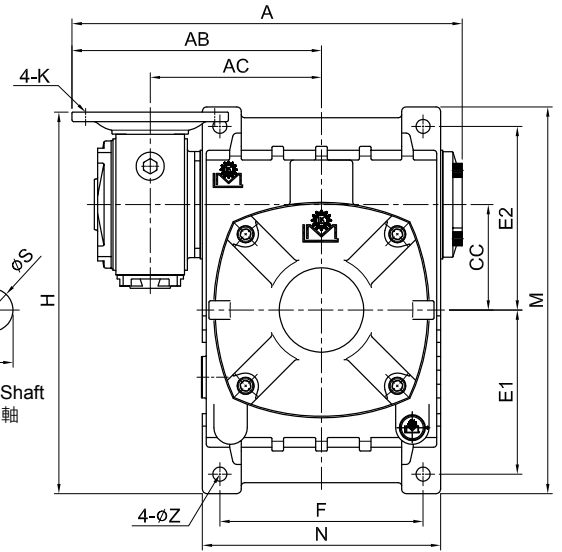

unit: mm

型號 Model	Ratio \ HP		A	AB	AC	X	BB	BC	BD	CC	H	馬達盤 IEC Motor Flange				腳座 Foot Stock					入力孔 Input Bore			出力軸 Output Shaft				重量 Weight (kg)		
	1/100 ~ 1/900	1/1000 ~ 1/3600										P	Q	R	K	E1	E2	F	M	N	G	Z	V	T	U	LS	S		D	WxYxLK
80	1/4	-	323	216	136	270	140	70	50	80	310	130	110	160	M8	130	150	140	315	183	20	15	12.7	4	11	65	32	35	10x8x60	25.4
100	1/2	1/4	370	238	158	310	170	90	60	100	365	130	110	160	M8	155	180	190	380	230	30	15	12.7	4	11	75	38	41	10x8x70	41.2
120	1	1/2	425	265	185	340	190	100	70	120	432	130	110	160	M8	185	215	220	450	266	30	18	16.3	5	14	85	45	48	12x8x80	74.8
			444	285		360					165	130	200	M10									21.8	6	19					
135	2	1	499	319	219	394	214	110	80	135	490	165	130	200	M10	210	235	260	495	305	35	18	21.8	6	19	95	55	59	15x10x90	98.6
155	3	2	557	358	258	453	253	140	100	155	471	165	130	200	M10	145	265	290	460	340	45	20	27.3	8	24	110	60	64	15x10x105	124.4
			582	383		478					215	180	248	M12									31.3	8	28					
175	5	3	638	408	284	506	262	150	120	175	543	215	180	248	M12	167	293	320	516	385	45	22	31.3	8	28	110	65	69	18x10x105	190.4

2-STAGE WORM REDUCER (WORM+WORM) SERIES

雙段蝸輪減速機 (蝸輪 + 蝸輪) 系列

MODEL : VOH

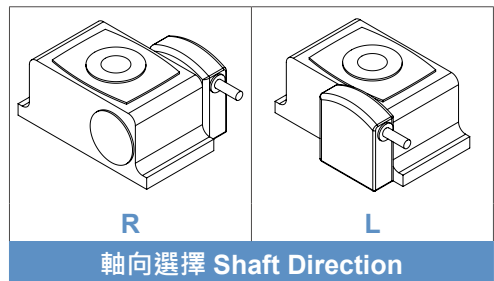

▲ 60#~135#

▲ 155#~175#

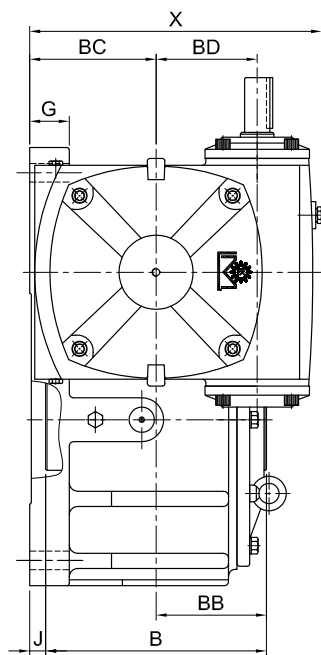

VOH155~175

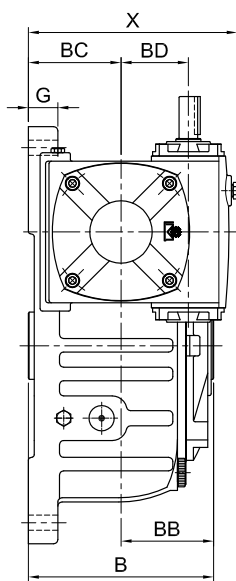

VOH60~135

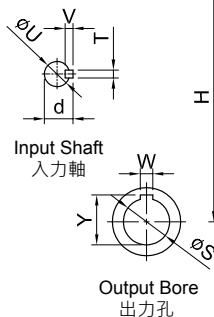

Input Shaft
入力軸

Output Bore
出力孔

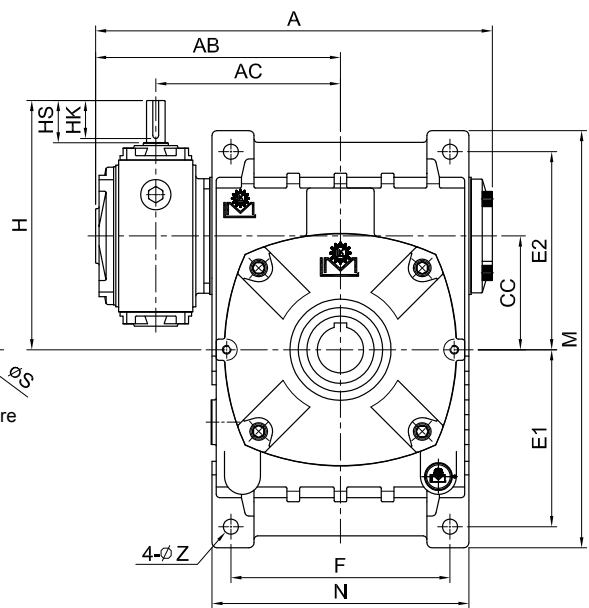

unit: mm

型號 Model	Ratio \ HP		腳座 Foot Stock										輸入軸 Input Shaft				出力孔 Output Bore			重量 Weight (kg)								
	1/100 ~ 1/900	1/1000 ~ 1/3600	A	AB	AC	J	B	X	BB	BC	BD	CC	H	E1	E2	F	M	N	G		Z	HS	U	d	TxVxHK	W	Y	S
	60	1/16	-	218	140	100	-	108	120	54	55	32	60	148	105	120	100	252	128		18	11	25	12	13.5	4x4x25	8	28.3
70	1/8	-	260	165	121	-	128	142	64	65	40	70	156	120	135	120	288	160	20	15	25	12	13.5	4x4x20	8	33.3	30	18.4
80	1/4	-	295	188	136	-	138	161	69	70	50	80	185	130	150	140	315	183	20	15	30	12	13.5	4x4x25	10	38.3	35	27.2
100	1/2	1/4	346	214	158	-	178	200	89	90	60	100	220	155	180	190	380	230	30	15	40	15	17	5x5x35	10	43.3	40	39
120	1	1/2	407	248	185	-	198	225	99	100	70	120	260	185	215	220	450	266	30	18	40	18	20	5x5x35	12	48.3	45	69.8
135	2	1	472	292	219	-	218	248	109	110	80	135	296	210	235	260	495	305	35	18	50	22	25	7x7x45	15	59.3	55	92.6
155	3	2	547	348	258	16.5	247	310	123.5	140	100	155	345	145	265	290	460	340	45	20	50	25	28	7x7x45	15	69.3	65	117.4
175	5	3	623	393	284	19	262	343	131	150	120	175	406	167	293	320	516	385	45	22	65	30	33	7x7x60	18	94.3	90	190.8

MODEL : VOHM



▲ 80#~135#



▲ 155#~175#

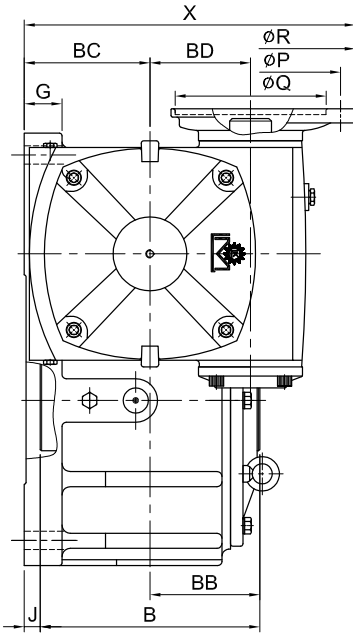
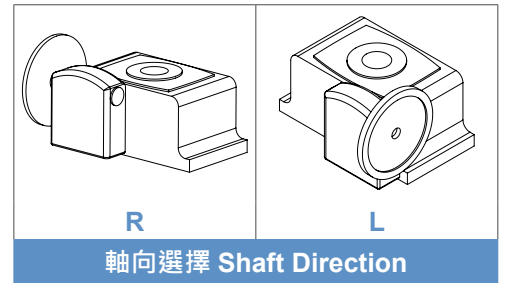

VOHM155~175

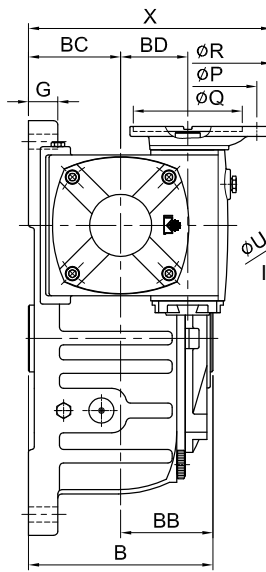

VOHM80~135

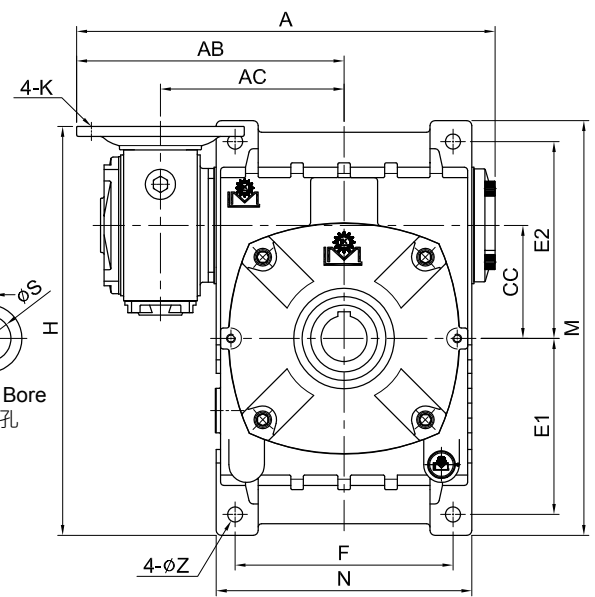

unit: mm

型號 Model	Ratio \ HP		A	AB	AC	J	B	X	BB	BC	BD	CC	H	馬達盤 IEC Motor Flange				腳座 Foot Stock						入力孔 Input Bore			出力孔 Output Bore			重量 Weight (kg)	
	1/100 ~ 1/900	1/1000 ~ 1/3600												P	Q	R	K	E1	E2	F	M	N	G	Z	V	T	U	W	Y		S
80	1/4	-	323	216	136	-	138	200	69	70	50	80	310	130	110	160	M8	130	150	140	315	183	20	15	12.7	4	11	10	38.3	35	28.2
100	1/2	1/4	370	238	158	-	178	230	89	90	60	100	365	130	110	160	M8	155	180	190	380	230	30	15	12.7	4	11	10	43.3	40	42
120	1	1/2	425	265	185	-	198	250	99	100	70	120	432	130	110	160	M8	185	215	220	450	266	30	18	16.3	5	14	12	48.3	45	71
			444	285				270					165	130	200	M10									21.8	6	19				
135	2	1	499	319	219	-	218	290	109	110	80	135	490	165	130	200	M10	210	235	260	495	305	35	18	21.8	6	19	15	59.3	55	93.8
155	3	2	557	358	258	16.5	247	340	123.5	140	100	155	471	165	130	200	M10	145	265	290	460	340	45	20	27.3	8	24	15	69.3	65	121.4
			582	383				365					475	215	180	248									M12	31.3	8				
175	5	3	638	408	284	19	262	395	131	150	120	175	530	215	180	248	M12	167	293	320	516	385	45	22	31.3	8	28	18	94.3	90	194.2

2-STAGE WORM REDUCER (WORM+WORM) SERIES

雙段蝸輪減速機 (蝸輪 + 蝸輪) 系列

MODEL : EH

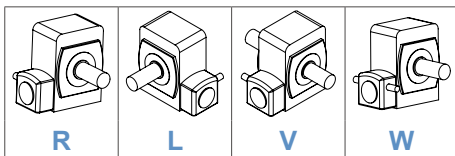
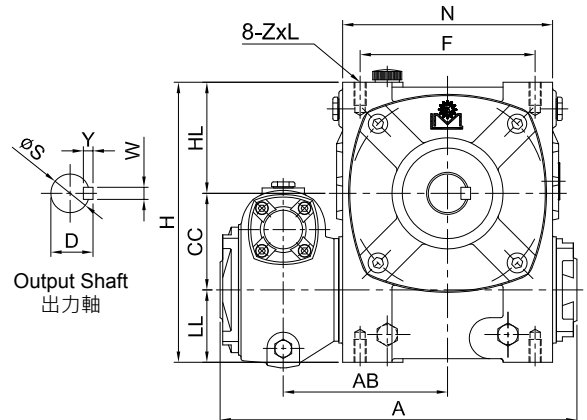
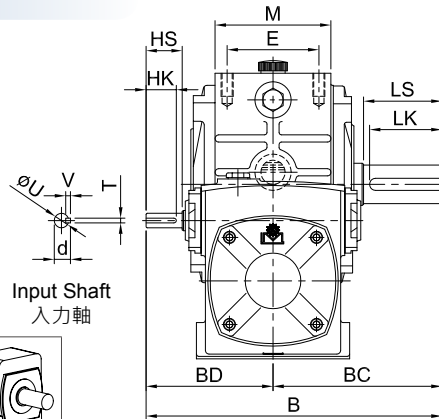

軸向選擇 Shaft Direction

unit: mm

型號 Model	Ratio \ HP		A	AB	B	BC	BD	CC	LL	HL	H	腳座 Foot Stock					入力軸 Input Shaft				出力軸 Output Shaft				重量 Weight (kg)
	1/100 ~ 1/900	1/1000 ~ 1/3600										E	F	M	N	ZxL	HS	U	d	TxVxHK	LS	S	D	WxYxLK	
60	1/16	-	207	100	198	110	86	60	42	75	177	55	100	77	124	M10x20	25	12	13.5	4x4x25	50	22	25	7x7x45	12
70	1/8	-	260	121	216	130	86	70	50	85	205	65	125	85	154	M10x20	25	12	13.5	4x4x20	60	28	31	7x7x55	17
80	1/4	-	295	136	245	140	105	80	60	92	232	75	145	96	174	M10x20	30	12	13.5	4x4x25	65	32	35	10x8x60	23.4
100	1/2	1/4	346	158	290	170	120	100	75	115	290	85	185	117	226	M12x24	40	15	17	5x5x35	75	38	41	10x8x70	41.8
120	1	1/2	407	185	330	190	140	120	95	155	370	100	220	132	264	M14x28	40	18	20	5x5x35	85	45	48	12x8x80	66.6
135	2	1	471	219	375	214	161	135	105	185	425	110	260	150	306	M16x35	50	22	25	7x7x45	95	55	59	15x10x90	97.2

MODEL : EHM

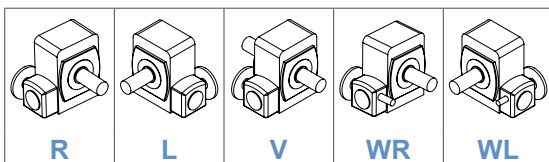
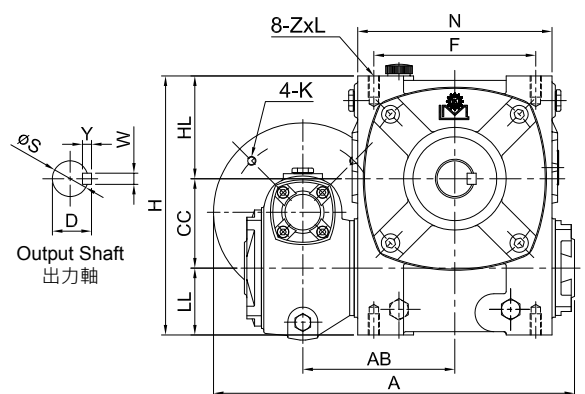
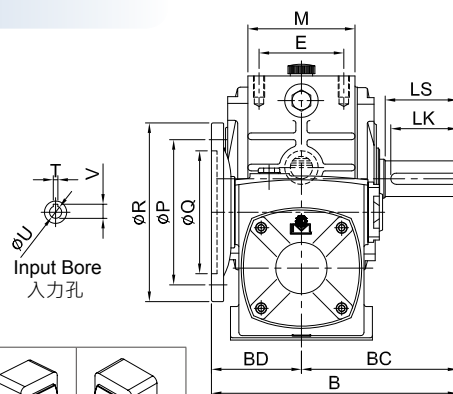

軸向選擇 Shaft Direction

unit: mm

型號 Model	Ratio \ HP		A	AB	B	BC	BD	CC	LL	HL	H	馬達盤 IEC Motor Flange				腳座 Foot Stock					入力孔 Input Bore			出力軸 Output Shaft				重量 Weight (kg)
	1/100 ~ 1/900	1/1000 ~ 1/3600										P	Q	R	K	E	F	M	N	ZxL	V	T	U	LS	S	D	WxYxLK	
80	1/4	-	323	136	221	140	81	80	60	92	232	130	110	160	M8	75	145	96	174	M10x20	12.7	4	11	65	32	35	10x8x60	24
100	1/2	1/4	370	158	256	170	86	100	75	115	290	130	110	160	M8	85	185	117	226	M12x24	12.7	4	11	75	38	41	10x8x70	44.8
120	1	1/2	424 444	185	291	190	101	120	95	155	370	130	110	160	M8 M10	100	220	132	264	M14x28	16.3	5	14	85	45	48	12x8x80	68
135	2	1	499	219	330	214	116	135	105	185	425	165	130	200	M10	110	260	150	306	M16x35	21.8	6	19	95	55	59	15x10x90	98.4
																					27.3	8	24					

MODEL : EOH

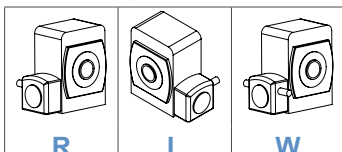

軸向選擇 Shaft Direction

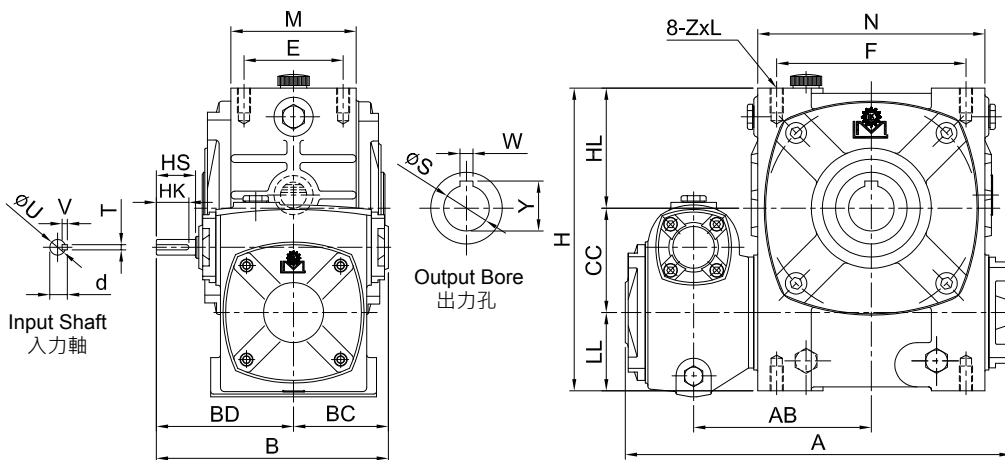

unit: mm

型號 Model	Ratio \ HP		A	AB	B	BC	BD	CC	LL	HL	H	腳座 Foot Stock				入力軸 Input Shaft				出力孔 Output Bore			重量 Weight (kg)	
	1/100 ~ 1/900	1/1000 ~ 1/3600										E	F	M	N	ZxL	HS	U	d	TxVxHK	W	Y		S
60	1/16	-	218	100	144	55	86	60	42	75	177	55	100	77	125	M10x20	25	12	13.5	4x4x25	8	28.3	25	13.2
70	1/8	-	260	121	151	65	86	70	50	85	205	65	125	87	158	M10x20	25	12	13.5	4x4x20	8	33.3	30	17.2
80	1/4	-	295	136	175	70	105	80	60	92	232	75	145	98	175	M10x20	30	12	13.5	4x4x25	10	38.3	35	25.4
100	1/2	1/4	346	158	210	90	120	100	75	115	290	85	185	117	226	M12x24	40	15	17	5x5x35	10	43.3	40	42.6
120	1	1/2	407	185	240	100	140	120	95	155	370	100	220	132	264	M14x28	40	18	20	5x5x35	12	48.3	45	68
135	2	1	471	219	271	110	161	135	105	185	425	110	260	150	306	M16x35	50	22	25	7x7x45	15	59.3	55	91.2

MODEL : EOHM

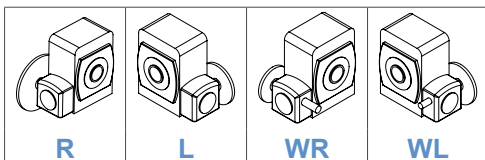
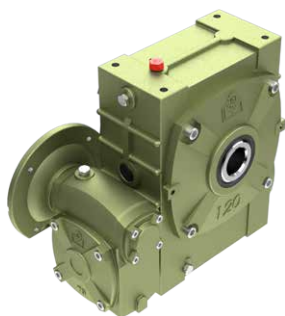

軸向選擇 Shaft Direction

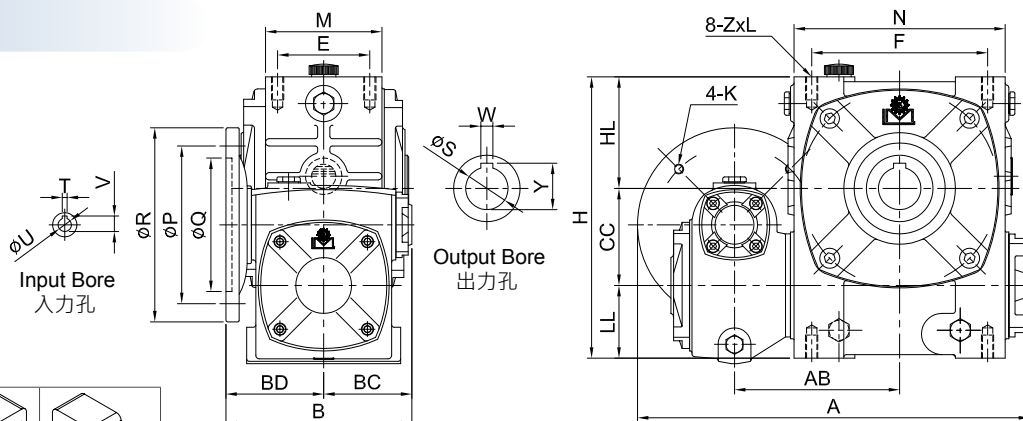

unit: mm

型號 Model	Ratio \ HP		A	AB	B	BD	BC	CC	LL	HL	H	馬達盤 IEC Motor Flange				腳座 Foot Stock				入力孔 Input Bore			出力孔 Output Bore			重量 Weight (kg)	
	1/100 ~ 1/900	1/1000 ~ 1/3600										P	Q	R	K	E	F	M	N	ZxL	V	T	U	W	Y		S
80	1/4	-	323	136	151	81	70	80	60	92	232	130	110	160	M8	75	145	98	175	M10x20	12.7	4	11	10	38.3	35	26
100	1/2	1/4	370	158	176	86	90	100	75	115	290	130	110	160	M8	85	185	117	226	M12x24	12.7 16.3	4 5	11 14	10	43.3	40	45.6
120	1	1/2	424 444	185	202	102	100	120	95	155	370	130 165	110 130	160 200	M8 M10	100	220	132	264	M14x28	16.3 21.8	5 6	14 19	12	48.3	45	69.4
135	2	1	499	219	226	116	110	135	105	185	425	165	130	200	M10	110	260	150	306	M16x35	21.8 27.3	6 8	19 24	15	59.3	55	92.4

2-STAGE WORM REDUCER (WORM+WORM) SERIES

雙段蝸輪減速機 (蝸輪 + 蝸輪) 系列

MODEL : VOFH

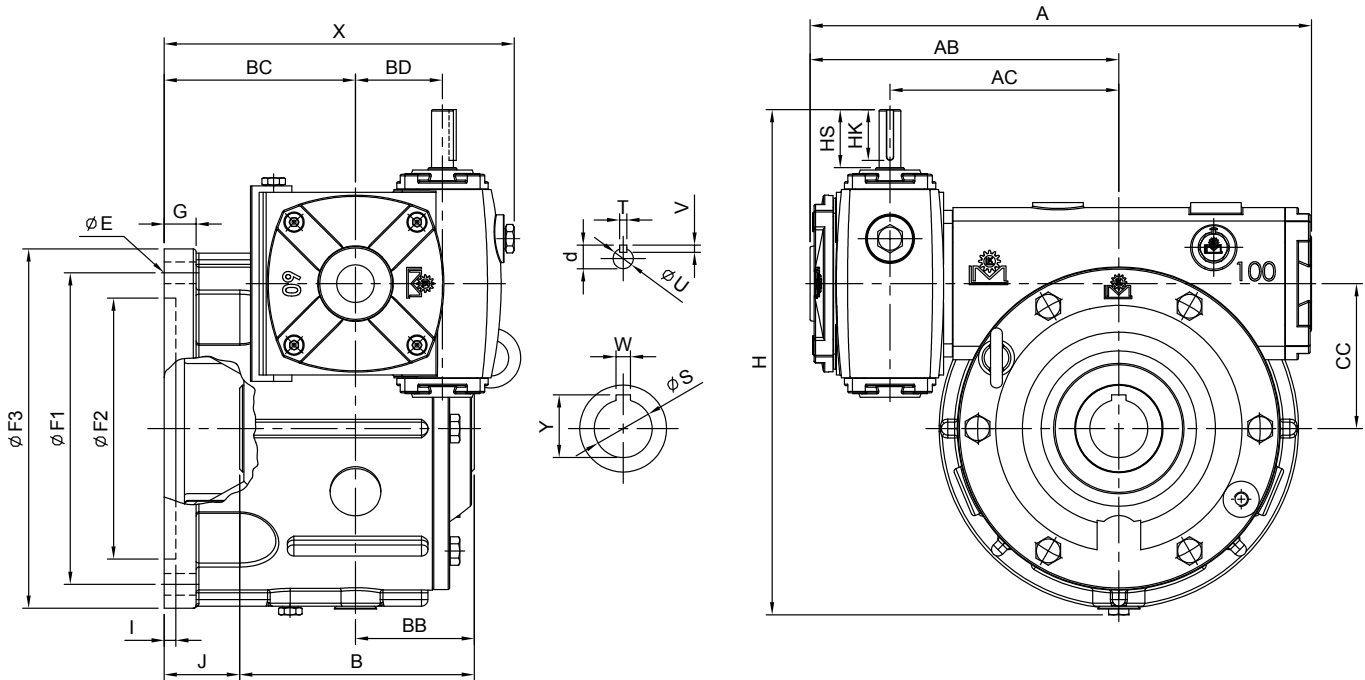
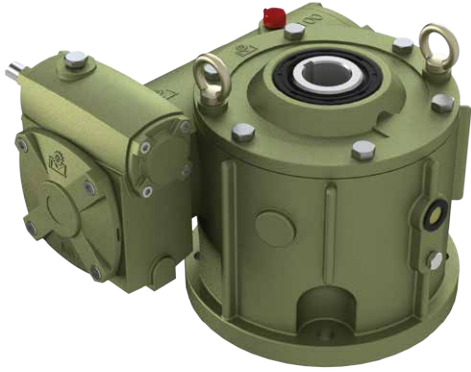

unit: mm

型號 Model	Ratio \ HP		腳座 Foot Stock										輸入軸 Input Shaft					出力孔 Output Bore			重量 Weight (kg)						
	1/100 ~ 1/900	1/1000 ~ 1/3600	A	AB	AC	J	B	X	BB	BC	BD	CC	H	E	F1	F2	F3	G	I	HS		U	d	TxVxHK	W	Y	S
	70	1/8	-	241	151	120	42	128	183	64	106	40	70	247	4-15	150	115	182	17	9		25	12	13.5	4x4x20	7	28.3
80	1/4	-	296	189	136	30	150	197	73	107	50	80	285	4-15	170	130	200	20	8	30	12	13.5	4x4x25	10	38.3	35	24.5
100	1/2	1/4	346	213	158	52	162	242	82	132	60	100	349	4-15	215	180	248	22	8	40	15	17	5x5x35	10	43.3	40	45.5
120	1	1/2	407	223	185	56	178	266	89	145	70	120	425	8-18	300	260	330	24	6	40	18	20	5x5x35	12	48.3	45	67.5
135	2	1	470	290	219	63	184	291	92	155	80	135	476	8-18	330	290	360	25	7	50	22	25	7x7x45	15	49.3	55	89.3

MODEL : VOFHM

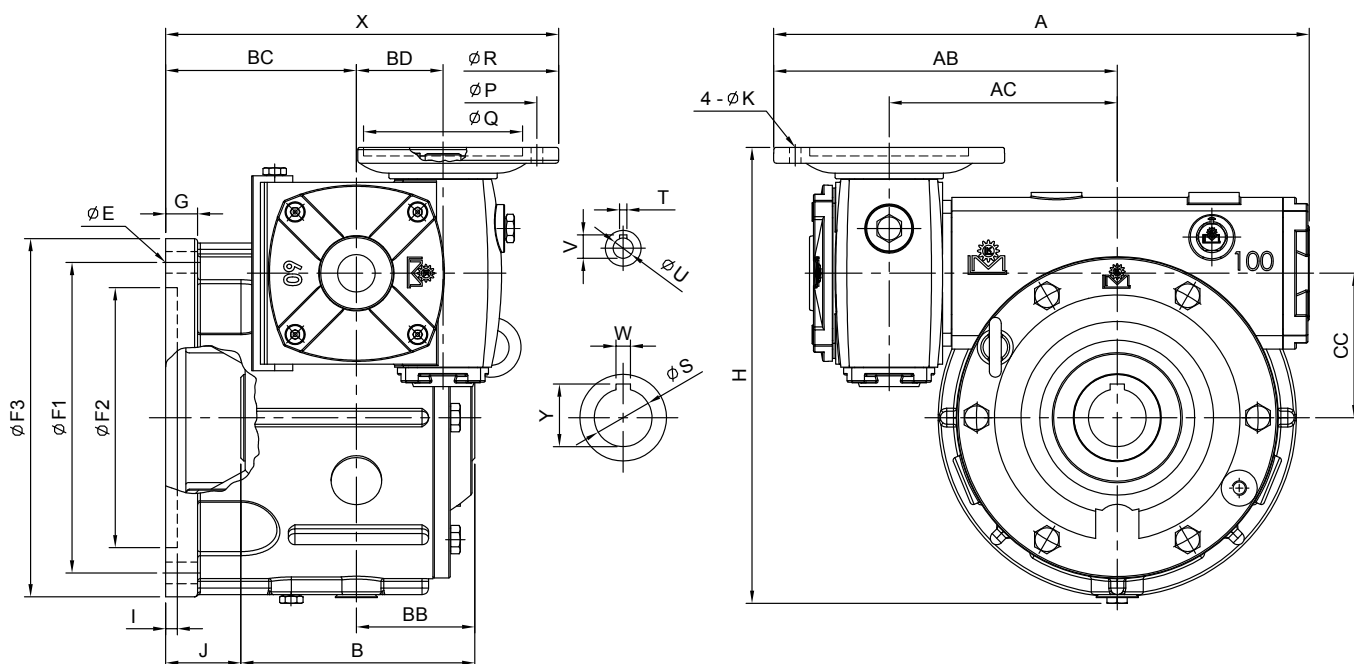

unit: mm

型號 Model	Ratio \ HP		A	AB	AC	J	B	X	BB	BC	BD	CC	H	馬達盤 IEC Motor Flange				腳座 Foot Stock					入力孔 Input Bore			出力孔 Output Bore			重量 Weight (kg)		
	1/100 ~ 1/900	1/1000 ~ 1/3600												P	Q	R	K	E	F1	F2	F3	G	I	V	T	U	W	Y		S	
80	1/4	-	323	216	136	30	150	237	73	107	50	80	262	130	110	160	M8	4-15	170	130	200	20	8	12.7	4	11	10	38.3	35	24.5	
100	1/2	1/4	371	238	158	52	162	272	82	132	60	100	316	130	110	160	M8	4-15	215	180	248	22	8	12.7	4	11	10	43.3	40	45.4	
120	1	1/2	425	265	185	56	178	295	89	145	70	120	386	130	110	160	M8	8-18	300	260	330	24	6	16.3	5	14	12	48.3	45	67.5	
135	2	1	498	319	219	63	184	335	92	155	80	135	432	165	130	200	M10	8-18	330	290	360	25	7	21.8	6	19	15	59.3	55	89.3	

2-STAGE WORM REDUCER (WORM+WORM) SERIES

雙段蝸輪減速機 (蝸輪 + 蝸輪) 系列

■ 安裝方向 Installation Direction (VOFH & VOFHM)

● 油面計
Oil Indicator

▼ 注油栓
Oil Plug

△ 排油栓
Oil Drain Plug

◆ 正常的使用方向可以使減速機保持較高的壽命。
The life time of gear reducer can be prolonged in proper direction.

◆ 安裝時請注意油面計、注油栓及排油栓的位置以便日後維護。
Please note the positions of oil gauge, oil filling plug and oil drain plug to facilitate the maintenance afterwards.

◆ 減速機使用方向特殊時，請與我們連繫。
For special installation direction, please contact us.

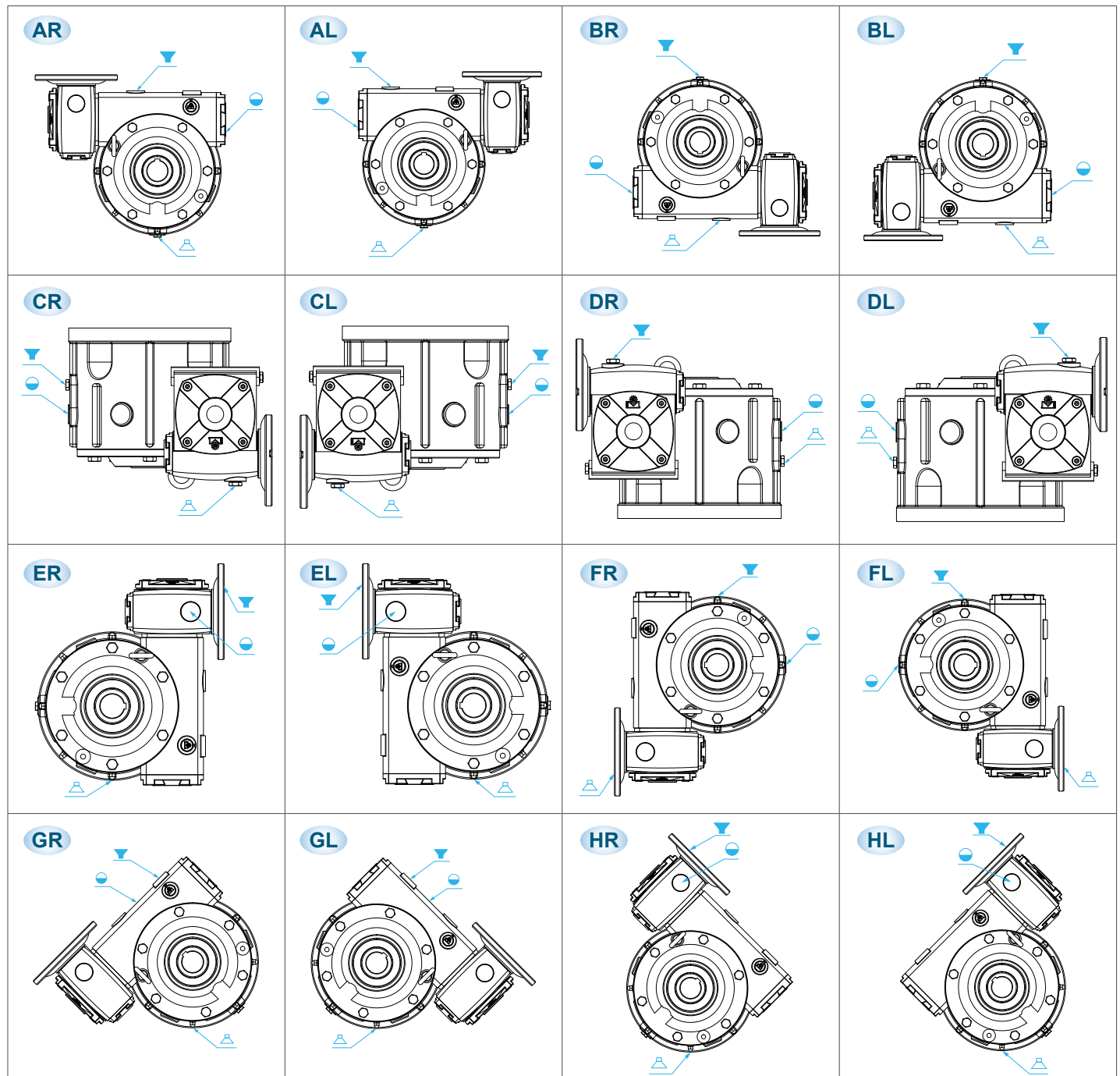

2-STAGE WORM REDUCER (GEAR+WORM) SERIES

雙段蝸輪減速機 (齒輪 + 蝸輪) 系列

齒輪 + 蝸輪系列 Gear + Worm Series

◆ 特點 Features :

1. 入力段螺旋齒輪減速 (減速比 1/3~1/5)
Input-stage spiral gear reduction (reduction ratio 1/3 ~ 1/5)
2. 出力段蝸輪減速 (減速比 1/10~1/60)
Output-stage worm reduction (reduction ratio 1/10 ~ 1/60)
3. 效率高·螺旋齒輪經研磨
High efficiency, grinding spiral gear.
4. 速比變化多 (1/80~1/300)
Various reduction ratios (1/8 ~ 1/300)
5. 適合低速高扭力之轉動
Suitable for low-speed and high-torque transmission.
6. 可選擇組合角度
Various assembling angles for choice.

◆ 型號 Model :

80#~155#

◆ 馬力 HP :

1/2HP~5HP

◆ 減速比 Ratio :

馬力 HP	型號 Model	可組立之減速比 Ratio
1/2	80	80, 90, 100, 120, 150, 160, 180, 200, 240, 250, 300
	100	80, 90, 100, 120, 150, 160, 180, 200, 240, 250, 300
1	80	80, 90, 100, 120, 150, 160,
	100	80, 90, 100, 120, 150, 160, 180, 200, 240, 250, 300
	120	80, 90, 100, 120, 150, 160, 180, 200, 240, 250, 300
2	100	80, 90, 100, 120, 150, 160
	120	80, 90, 100, 120, 150, 160, 180, 200
	135	80, 90, 100, 120, 150, 160, 180, 200, 240, 250, 300
3	135	80, 90, 100, 120, 150, 160, 180, 200
	155	80, 90, 100, 120, 150, 160, 180, 200, 240, 250, 300
5	155	80, 90, 100, 120, 150, 160

油量表 Oil Capacities (unit: ℓ)

Type Model	LG LGM	LOG LOGM	VG VGM	VOG VOGM	EG EGM	EOG EOGM	VOFG VOFGM
80	1	1	1.6	1.6	1	1	1.4
100	1.8	1.8	2.9	2.9	1.8	1.8	2
120	2.8	2.8	4.6	4.6	2.8	2.8	2.8
135	4.6	4.6	7.1	7.1	4.6	4.6	4.2
155	7	7	-	-	-	-	-

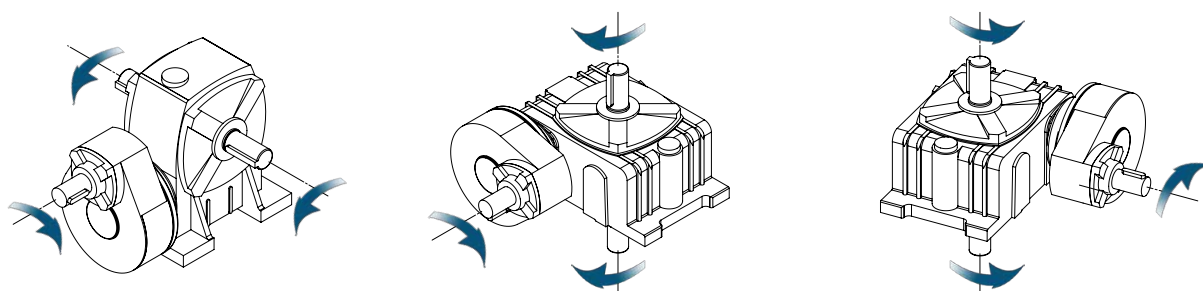
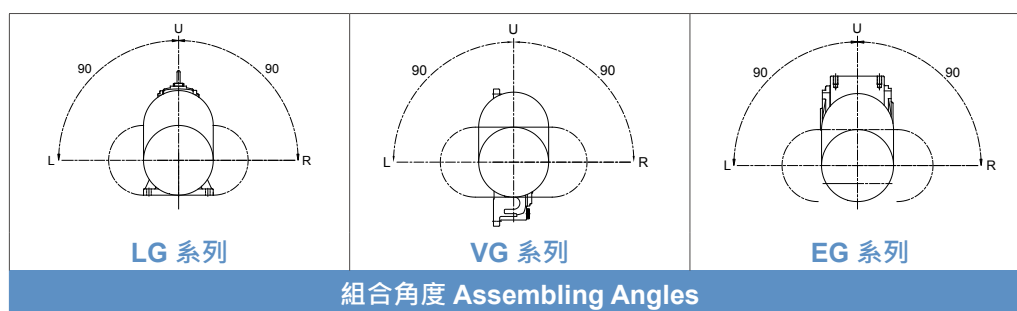

旋轉方向
Rotation Directions

分解系統圖 System Drawing

MODEL : LG

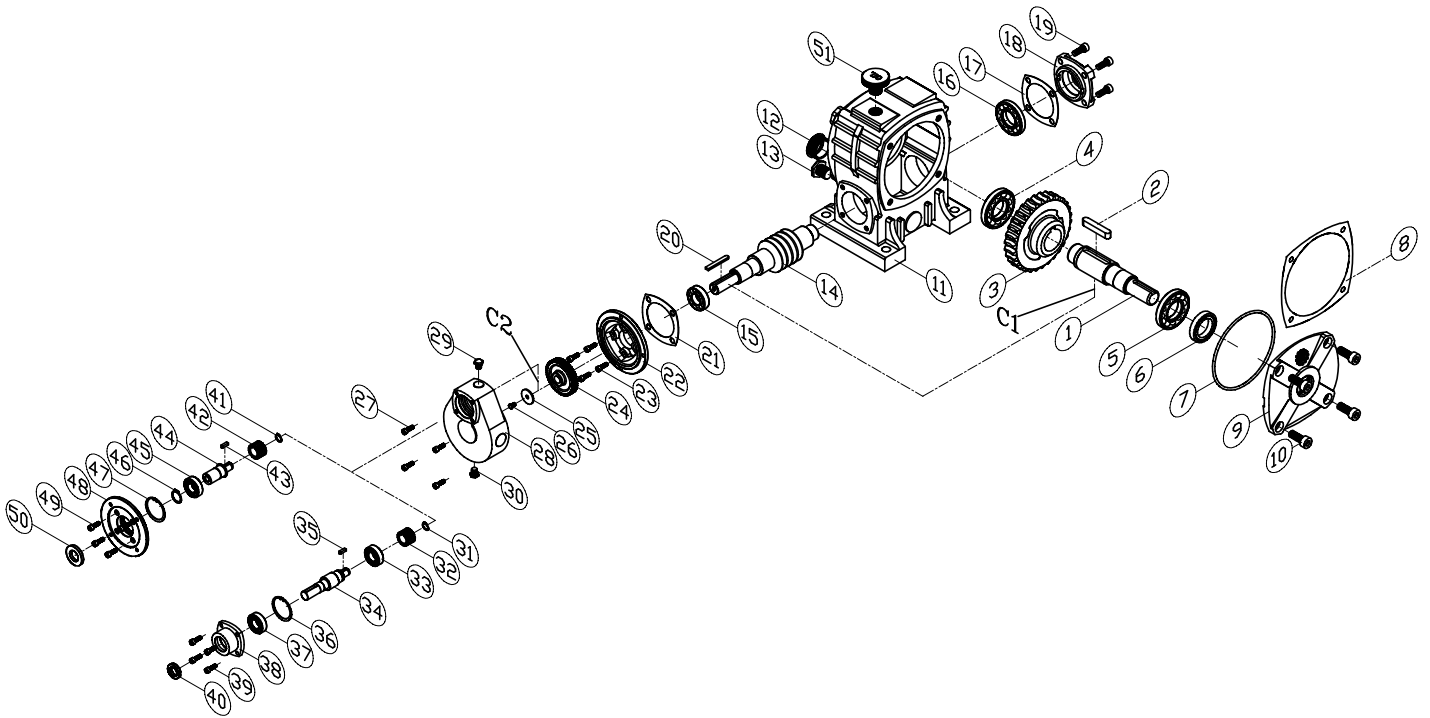

NO.	零件名稱	Name of Parts
1	出力軸	Output Shaft
2	雙圓鍵	Key
3	蝸輪	Worm Wheel
4	滾珠軸承	Ball Bearing
5	滾珠軸承	Ball Bearing
6	油封	Oil Seal
7	O 型環	O Ring
8	非石棉墊片	Asbestos Free Gasket
9	出力軸蓋	Output Shaft Cover
10	六角承窩頭螺絲	Hex Screw
11	蝸輪箱	Outer Shell
12	油鏡	Oil Gauge
13	排油栓	Drain Plug
14	蝸桿 (入力軸)	Worm Shaft (Input Shaft)
15	滾錐軸承	Taper Roller Bearing
16	滾錐軸承	Taper Roller Bearing
17	非石棉墊片	Asbestos Free Gasket
18	入力軸蓋	Input Shaft Cover
19	六角承窩頭螺絲	Hex Screw
20	雙圓鍵	Key
21	非石棉墊片	Asbestos Free Gasket
22	連接盤	Adapter
23	六角承窩頭螺絲	Hex Screw
24	B 齒輪	B Gear
25	鐵制華司	Shim Washer
26	六角螺絲	Hexagon Head Bolt
27	六角承窩頭螺絲	Hex Screw

NO.	零件名稱	Name of Parts
28	偏心齒輪箱	Gear Box
29	油栓	Oil Plug
30	排油栓	Drain Plug
31	扣環 (S)	Snap Ring (S)
32	A 齒輪	A Gear
33	滾珠軸承	Ball Bearing
34	A 齒輪軸	A Gear Shaft
35	雙圓鍵	Key
36	扣環 (R)	Snap Ring (R)
37	滾珠軸承	Ball Bearing
38	入力軸蓋	Input Shaft Cover
39	六角承窩頭螺絲	Hex Screw
40	油封	Oil Gauge
41	扣環 (S)	Snap Ring (S)
42	A 齒輪	A Gear
43	單圓鍵	Key
44	A 齒輪軸	A Gear Shaft
45	滾珠軸承	Ball Bearing
46	扣環 (S)	Snap Ring (S)
47	扣環 (R)	Snap Ring (R)
48	馬達盤	Motor Flange
49	六角承窩頭螺絲	Hex Screw
49	六角承窩頭螺絲	Hex Screw
50	油封	Oil Seal
51	注油栓	Oil Plug
8	100#(含) 以上不使用 非石棉墊片	Model 100# and above are without Asbestos Free Gasket

2-STAGE WORM REDUCER (GEAR+WORM) SERIES

雙段蝸輪減速機 (齒輪 + 蝸輪) 系列

MODEL : LG

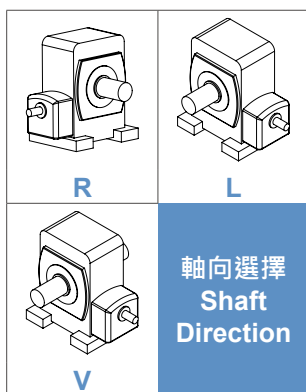
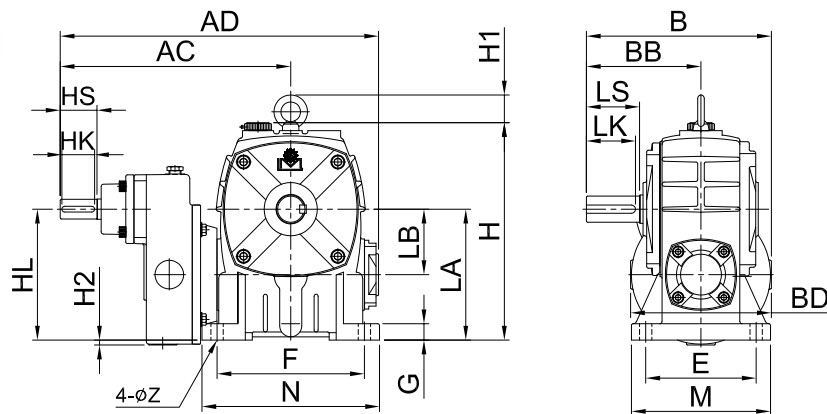

軸向選擇
Shaft
Direction

型號 Model	出力軸 Output Shaft				重量 (kg) Weight
	LS	S	D	WxYxLK	
80	65	32	35	10x8x60	32.2
100	75	38	41	10x8x70	48.8
120	85	45	48	12x8x80	73
135	95	55	59	15x10x90	103.4
155	110	60	64	15x10x105	133.6

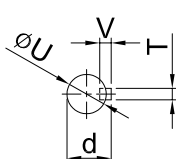

Input Shaft
入力軸

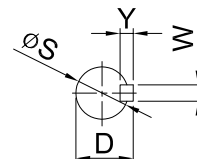

Output Shaft
出力軸

MODEL : LOG

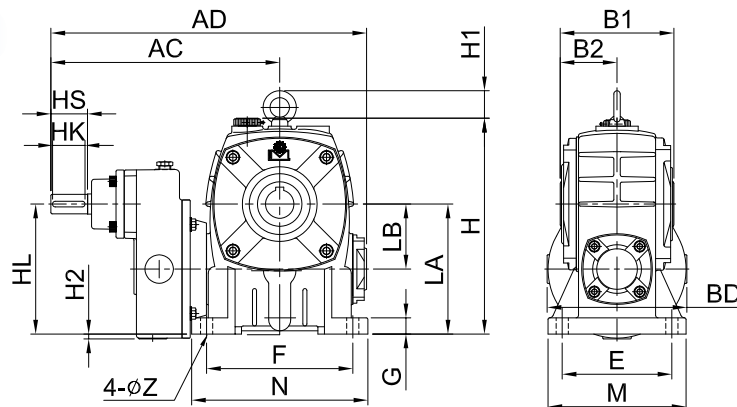

型號 Model	出力孔 Output Bore			重量 (kg) Weight
	W	Y	S	
80	10	38.3	35	30.6
100	10	43.3	40	49.6
120	12	48.3	45	74.8
135	15	59.3	55	106.8
155	15	69.3	65	128.8

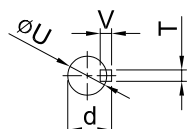

Input Shaft
入力軸

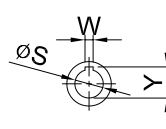

Output Bore
出力孔

unit: mm

型號 Model	馬力 HP (4P)	減速比 Ratio	AC	AD	B	BB	B1	B2	BD	H1	H2	LB	H	HL	LA	腳座 Foot Stock					入力軸 Input Shaft				
																E	F	M	N	G	Z	HS	U	d	TxVxHK
80	1/2	80~300	282	389	235	140	138	70	172	-	6	80	266	160	160	135	180	170	217	20	15	45	24	27	7x7x40
	1	80~160														155	220	195	270	25	15	45	24	27	7x7x40
100	1	80~300	306	439	267.5	170	178	90	172	36	-	100	335	180	200	155	220	195	270	25	15	45	24	27	7x7x40
	2	80~160														180	260	230	320	30	18	45	24	27	7x7x40
120	1	80~300	344	504	305	190	198	100	172	34	-	120	398	200	240	180	260	230	320	30	18	45	24	27	7x7x40
	2	80~200														200	290	250	350	32	18	55	28	31	7x7x50
135	2	80~300	401	582	322	214	218	110	240	41	-	135	440	227	270	200	290	250	350	32	18	55	28	31	7x7x50
	3	80~200														220	320	285	380	38	20	55	28	31	7x7x50
155	3	80~300	420	620	392	253	247	123.5	240	37	-	155	486	227	290	220	320	285	380	38	20	55	28	31	7x7x50
	5	80~160														220	320	285	380	38	20	55	28	31	7x7x50

MODEL : LGM

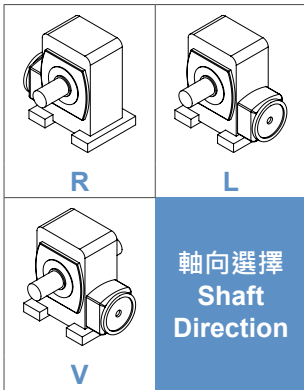
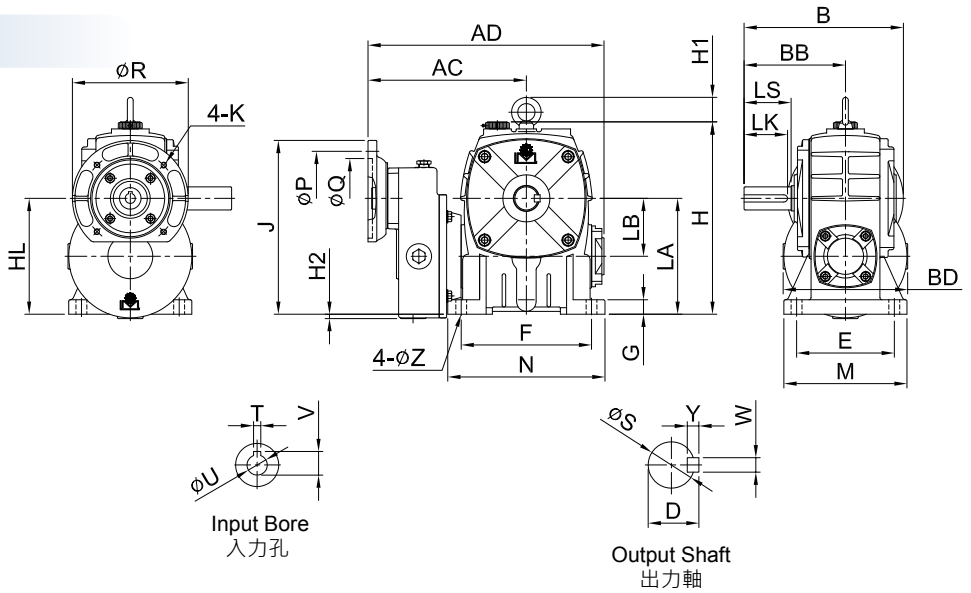

型號 Model	出力軸 Output Shaft				重量 (kg) Weight
	LS	S	D	WxYxLK	LGM
80	65	32	35	10x8x60	31.6
100	75	38	41	10x8x70	48
120	85	45	48	12x8x80	72.2
135	95	55	59	15x10x90	101.2
155	110	60	64	15x10x105	131.6

MODEL : LOGM

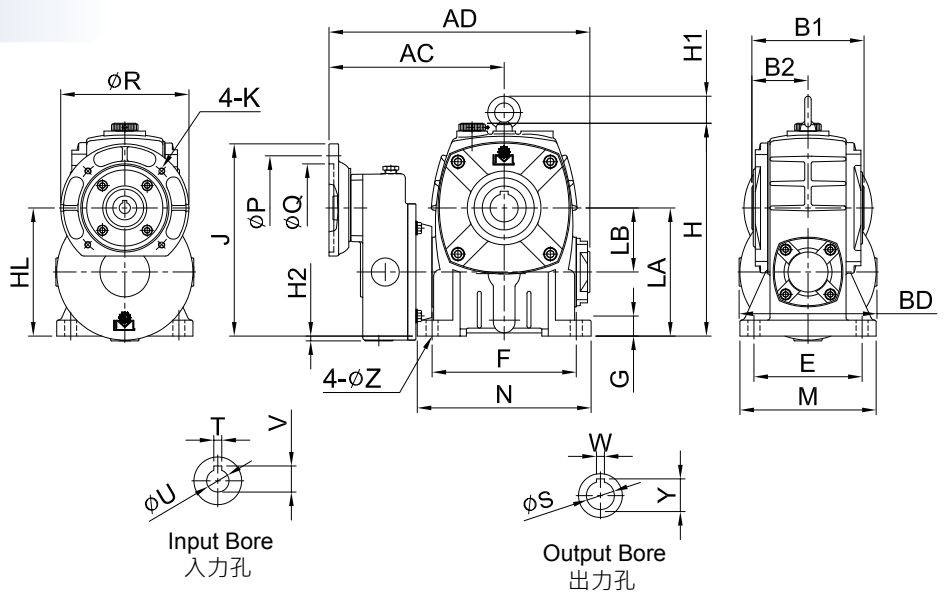

型號 Model	出力孔 Output Bore			重量 (kg) Weight
	W	Y	S	LOGM
80	10	38.3	35	30
100	10	43.3	40	48.6
120	12	48.3	45	74
135	15	59.3	55	104.6
155	15	69.3	65	126.8

型號 Model	馬力 HP (4P)	減速比 Ratio	AC	AD	B	BB	B1	B2	BD	H1	H2	LB	H	HL	LA	J	馬達盤 IEC Motor Flange				腳座 FOOT STOCK					入力孔 Input Bore			
																	P	Q	R	K	E	F	M	N	G	Z	V	T	U
80	1/2	80~300	219	326	235	140	138	70	172	-	6	80	266	160	160	246	130	110	160	M8	135	180	170	214	20	15	16.3	5	14
			220	327	240												165	130	200	M10							21.7	6	19
100	1	80~300	244	377	270	170	178	90	172	36	-	100	335	180	200	280	165	130	200	M10	155	220	195	270	25	15	21.7	6	19
			244	377	270																						165	130	200
120	2	80~160	282	442	305	190	198	100	172	34	-	120	398	200	240	300	165	130	200	M10	180	260	230	310	30	18	21.7	6	19
			282	442	305																						165	130	200
135	3	80~200	306	487	322	214	218	110	240	41	-	135	440	227	270	353	165	130	200	M10	200	290	250	340	32	18	27.3	8	24
			306	487	322																						165	130	200
155	5	80~160	325	525	392	253	247	123.5	240	37	-	155	486	227	290	353	215	180	252	M12	220	320	285	380	38	20	31.3	8	28
			325	525	392																						165	130	200

unit: mm

2-STAGE WORM REDUCER (GEAR+WORM) SERIES

雙段蝸輪減速機 (齒輪 + 蝸輪) 系列

MODEL : EG

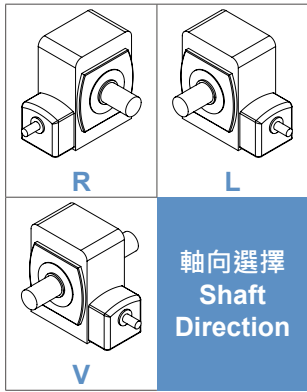
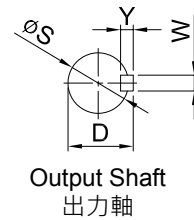
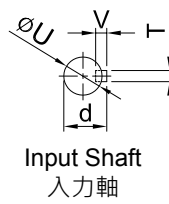
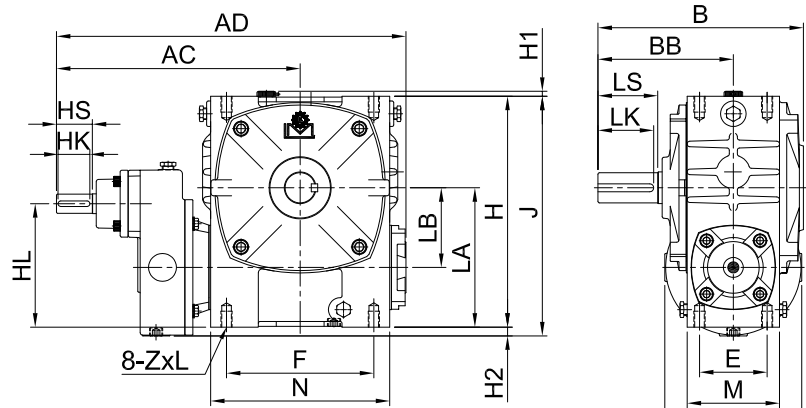

型號 Model	出力軸 Output Shaft				重量 (kg) Weight
	LS	S	D	WxYxLK	EG
80	65	32	35	10x8x60	30.4
100	75	38	41	10x8x70	46.4
120	85	45	48	12x8x80	68.8
135	95	55	59	15x10x90	103

MODEL : EOG

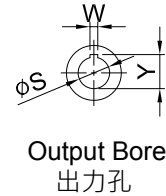
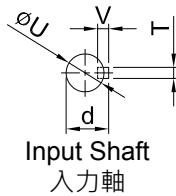
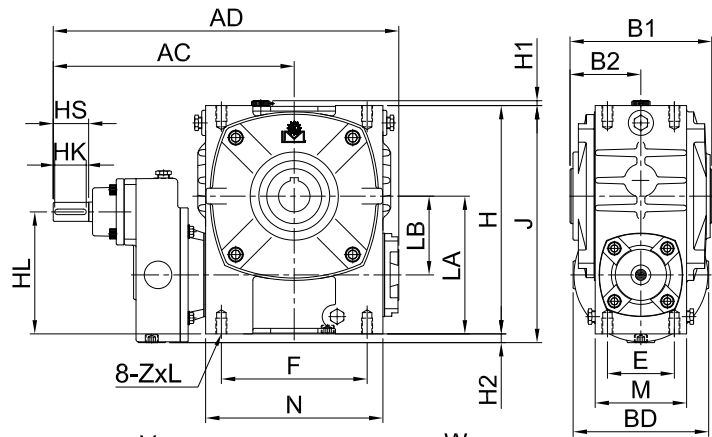

型號 Model	出力孔 Output Bore			重量 (kg) Weight
	W	Y	S	EOG
80	10	38.3	35	32
100	10	43.3	40	47.8
120	12	48.3	45	70.2
135	15	59.3	55	97

unit: mm

型號 Model	馬力 HP (4P)	減速比 Ratio	AC	AD	B	BB	B1	B2	BD	H1	H2	H	HL	LA	LB	J	腳座 Foot Stock					入力軸 Input Shaft			
																	E	F	M	N	ZxL	HS	U	d	TxVxHK
80	1/2	80~300	282	289	235	140	138	70	172	-	26	232	140	140	80	267	75	145	96	174	M10x18	45	24	27	7x7x40
		80~160																							
100	1	80~300	306	439	256	170	178	90	172	6	11	301	155	175	100	301	85	185	116	225	M12x20	45	24	27	7x7x40
		80~160																							
120	1	80~300	335	495	288	198	198	100	172	6	-	370	175	215	120	370	100	220	132	264	M14x28	45	24	27	7x7x40
		80~200																							
135	2	80~300	402	583	319	214	218	110	240	6	-	425	228	240	135	425	110	260	150	306	M16x30	55	28	31	7x7x50
		80~200																							

2-STAGE WORM REDUCER (GEAR+WORM) SERIES

雙段蝸輪減速機 (齒輪 + 蝸輪) 系列

MODEL : UG

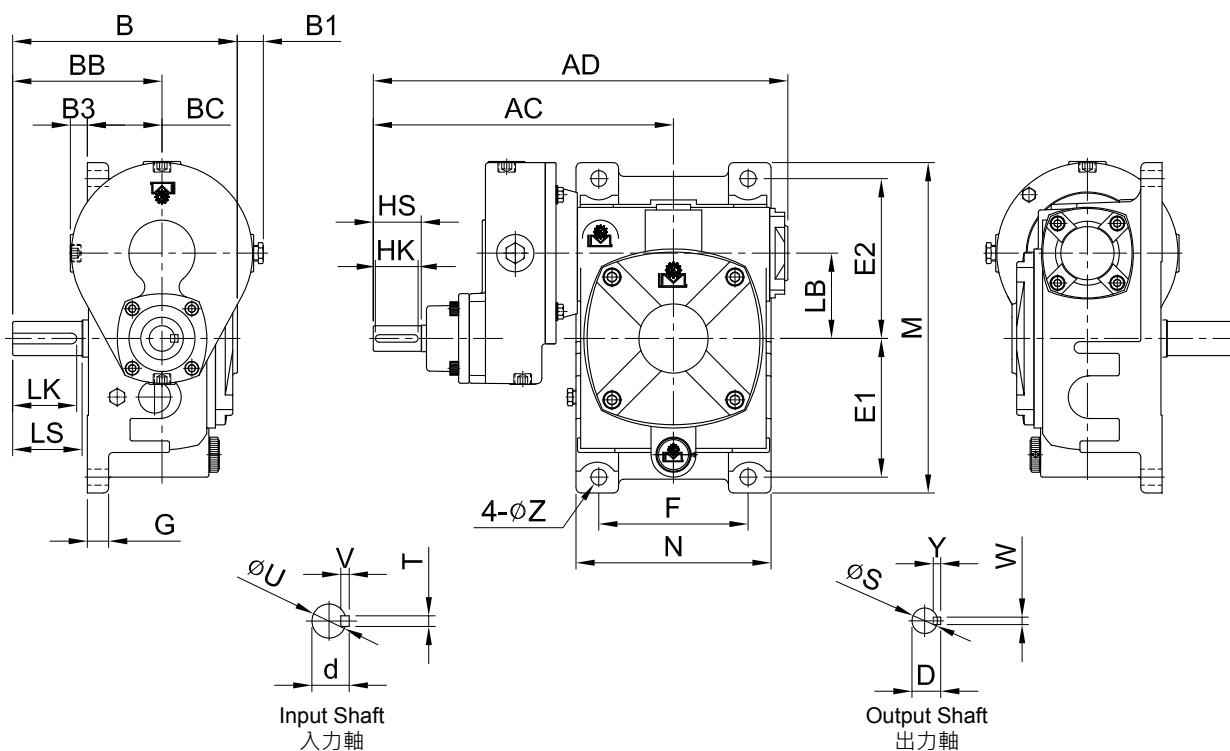
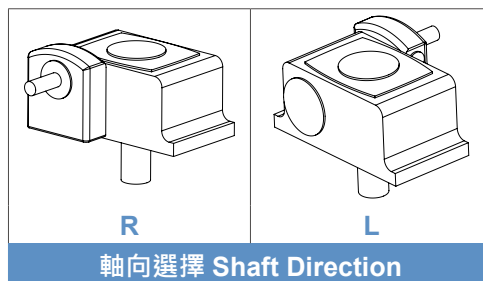

unit: mm

型號 Model	馬力 HP (4P)	減速比 Ratio	AC	AD	B	BB	BC	B1	B3	LB	腳座 Foot Stock						輸入軸 Input Shaft				輸出軸 Output Shaft				重量 Weight (kg)	
											E1	E2	M	F	N	G	Z	HS	U	d	TxVxHK	LS	S	D		WxYxLK
80	1/2 1	80~300 80~160	282	389	211	140	70	24.5	16	80	130	80	315	140	183	20	15	45	24	27	7x7x40	65	32	35	10x8x60	31.4
100	1 2	80~300 80~160	306	439	260	170	90	6	0	100	155	100	380	190	230	26	15	45	24	27	7x7x40	75	38	41	10x8x70	50.8
120	1 2	80~300 80~200	344	504	292	190	100	-	-	120	185	120	450	220	266	30	18	45	24	27	7x7x40	85	45	48	12x8x80	72.6
135	2 3	80~300 80~200	401	582	324	214	110	16	-	135	210	235	495	260	305	35	18	55	28	31	7x7x50	95	55	59	15x10x90	102.8
155	3 5	80~300 80~160	420	620	393	253	140	-	-	155	145	265	460	290	340	45	20	55	28	31	7x7x50	110	60	64	15X10X105	136

MODEL : UGM

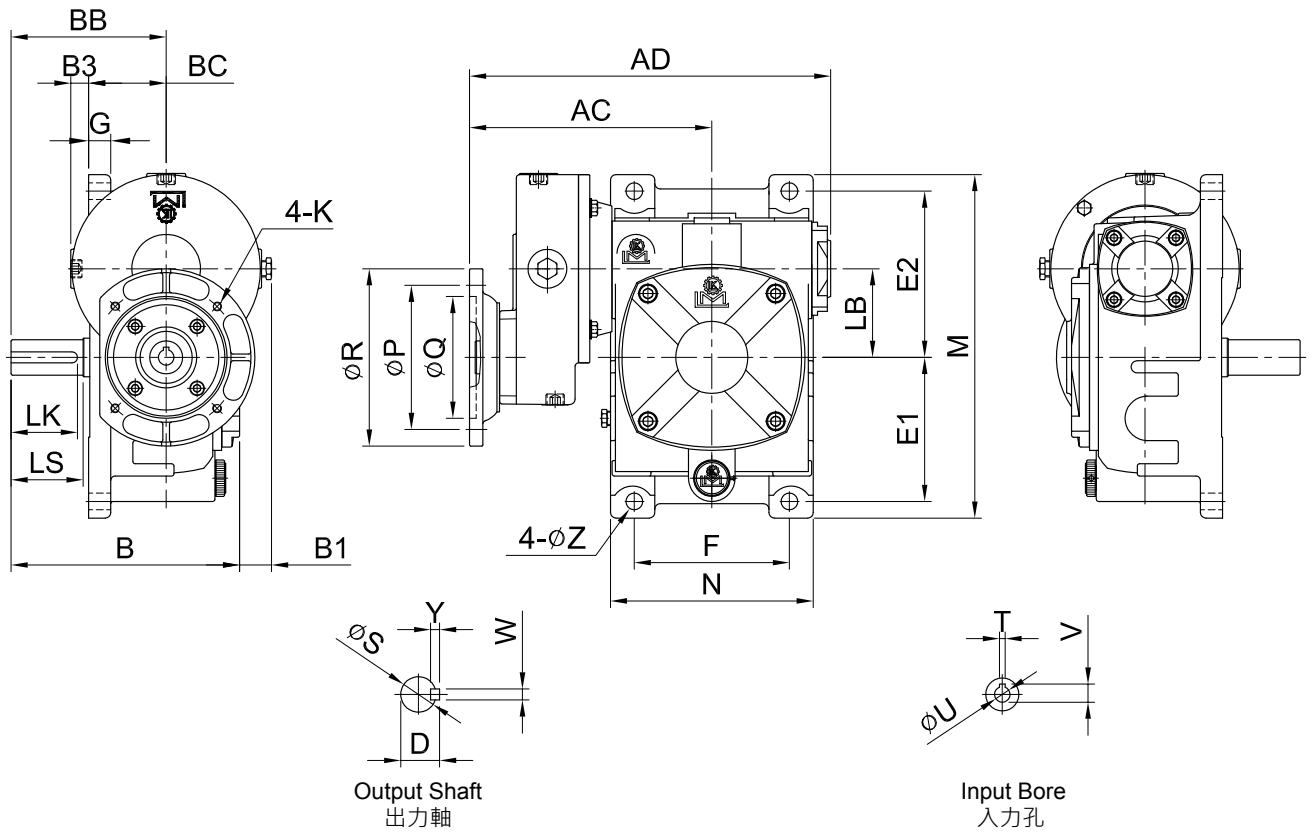
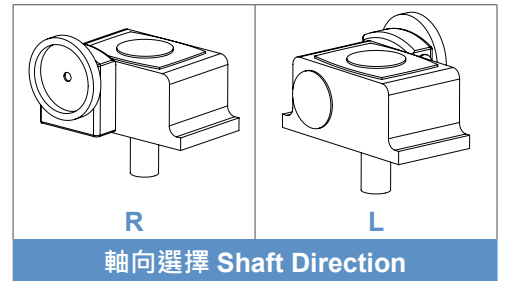

unit: mm

型號 Model	馬力 HP (4P)	減速比 Ratio	馬達盤 IEC Motor Flange											腳座 Foot Stock					入力孔 Input Bore			出力軸 Output Shaft					重量 Weight (kg)			
			AC	AD	B	BB	BC	B1	B3	LB	P	Q	R	K	E1	E2	M	F	N	G	Z	V	T	U	LS	S		D	WxYxLK	
80	1/2	80~300	219	326	235	140	70	29	16	80	130	110	160	M8	130	150	315	140	183	20	15	16.3	5	14	65	32	35	10x8x60	31.6	
	1	80~160	220	327	240						165	130	200	M10								21.7	6	19						
100	1	80~300	244	377	270	170	90	11	0	100	165	130	200	M10	155	180	380	190	230	26	15	21.7	6	19	75	38	41	10x8x70	50	
	2	80~160																				27.3	8	24						
120	1	80~300	282	442	292	190	100	-	-	120	165	130	200	M10	185	215	450	220	266	30	18	21.7	6	19	85	45	48	12x8x80	71.8	
	2	80~200																				27.3	8	24						
135	2	80~300	306	487	487	214	110	15	-	135	165	130	200	M10	210	235	495	260	305	35	18	27.3	8	24	95	55	59	15x10x90	100.6	
	3	80~200						16	-		215	180	250	M12								31.3	8	28						
155	3	80~300	325	525	525	253	140	-	-	155	215	180	250	M12	145	265	460	290	340	45	20	31.3	8	28	110	60	64	15X10X105	134	
	5	80~160																												

2-STAGE WORM REDUCER (GEAR+WORM) SERIES

雙段蝸輪減速機 (齒輪 + 蝸輪) 系列

MODEL : VG



型號 Model	出力軸 Output Shaft				重量 (kg) Weight
	LS	S	D	WxYxLK	VG
80	65	32	35	10x8x60	31.4
100	75	38	41	10x8x70	50.8
120	85	45	48	12x8x80	72.8
135	95	55	59	15x10x90	102.8
155	110	60	64	15X10X105	136

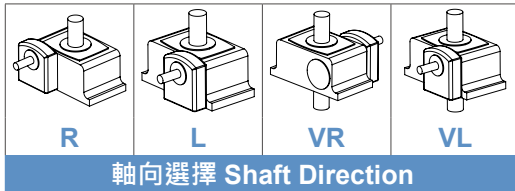
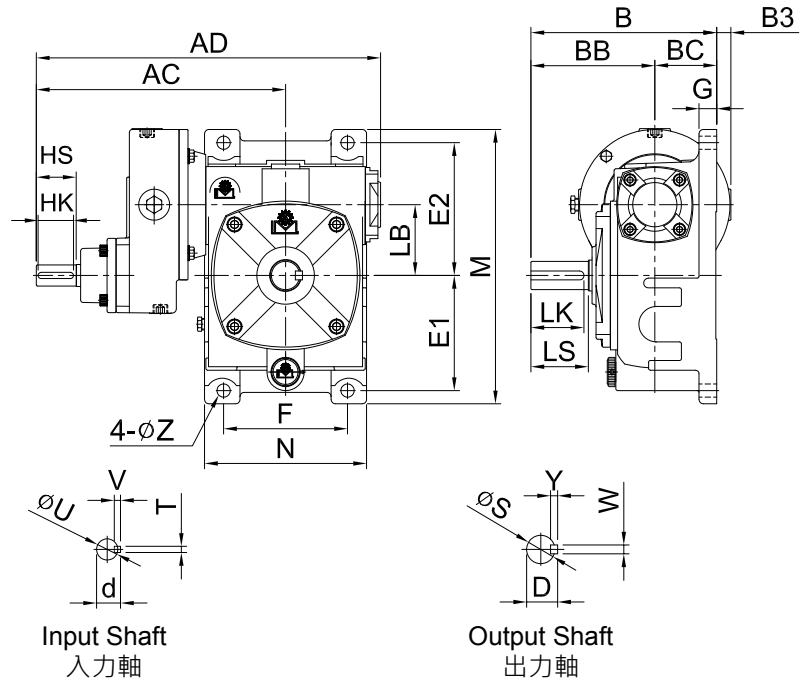

MODEL : VOG

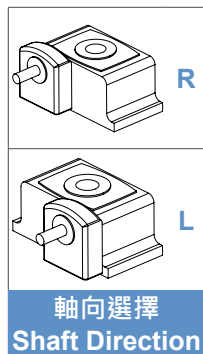

型號 Model	出力孔 Output Bore			重量 (kg) Weight
	W	Y	S	VOG
80	10	38.3	35	32.8
100	10	43.3	40	50.8
120	12	48.3	45	72.8
135	15	59.3	55	102.2
155	15	69.3	65	133

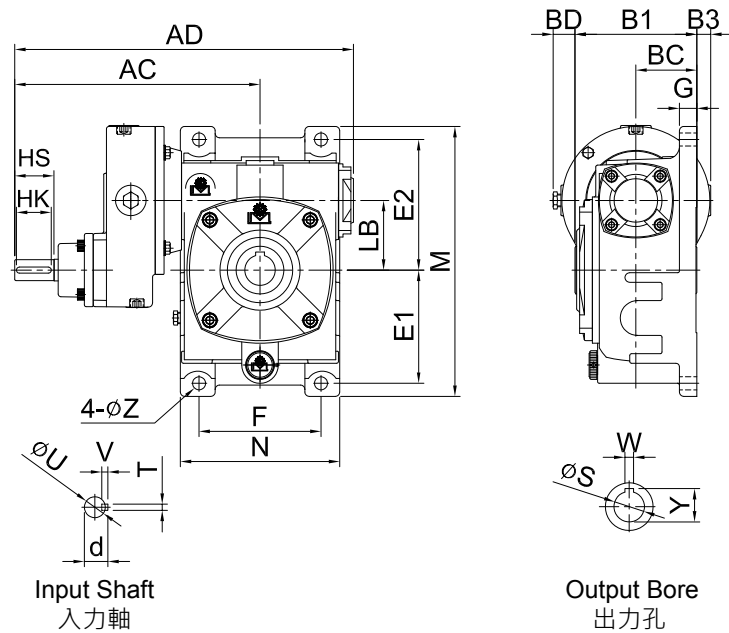

unit: mm

型號 Model	馬力 HP (4P)	減速比 Ratio	AC	AD	B	BB	BC	BD	B1	B3	LB	腳座 Foot Stock							入力軸 Input Shaft			
												E1	E2	M	F	N	G	Z	HS	U	d	TxVxHK
80	1/2	80~300	282	389	210	140	70	25	139	16	80	130	150	315	140	183	20	15	45	24	27	7x7x40
	1	80~160																				
100	1	80~300	306	439	260	170	90	5	179	0	100	155	180	380	190	230	26	15	45	24	27	7x7x40
	2	80~160																				
120	1	80~300	344	504	290	190	100	0	199	0	120	185	215	450	220	266	30	18	45	24	27	7x7x40
	2	80~200																				
135	2	80~300	401	582	324	214	110	16	219	16	135	210	235	495	260	305	35	18	55	28	31	7x7x50
	3	80~200																				
155	3	80~300	420	620	393	253	140	2.5	263.5	0	155	145	265	460	290	340	45	20	55	28	31	7x7x50
	5	80~160																				

MODEL : VGM

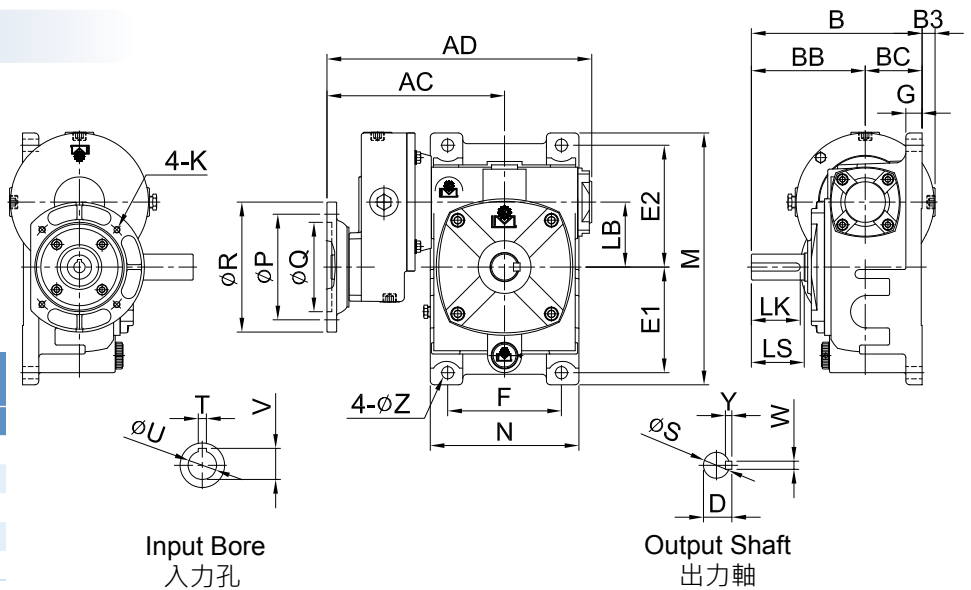

型號 Model	出力軸 Output Shaft				重量 (kg) Weight VGM
	LS	S	D	WxYxLK	
80	65	32	35	10x8x60	31.6
100	75	38	41	10x8x70	51
120	85	45	48	12x8x80	72
135	95	55	59	15x10x90	100.8
155	110	60	64	15X10X105	134

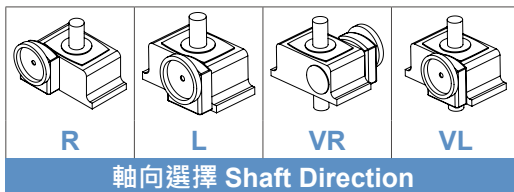

MODEL : VOGM

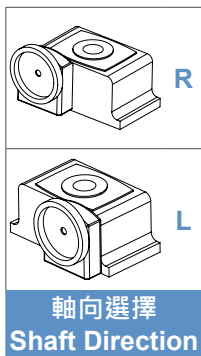
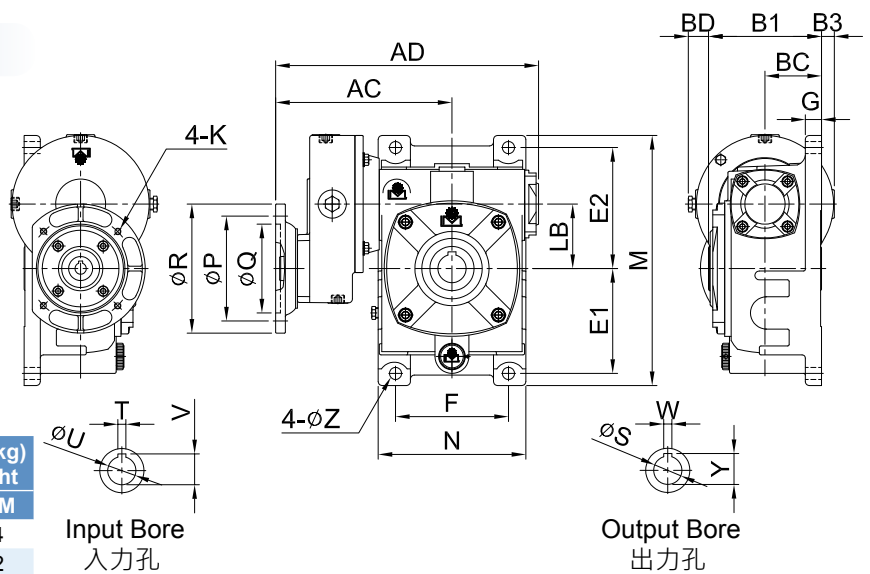

型號 Model	出力孔 Output Bore			重量 (kg) Weight VOGM
	W	Y	S	
80	10	38.3	35	32.4
100	10	43.3	40	49.2
120	12	48.3	45	72
135	15	59.3	55	100.2
155	15	69.3	65	131

unit: mm

型號 Model	馬力 HP (4P)	減速比 Ratio	AC	AD	B	BB	BC	BD	B1	B3	LB	馬達盤 IEC Motor Flange				腳座 Foot Stock						入力孔 Input Bore			
												P	Q	R	K	E1	E2	M	F	N	G	Z	V	T	U
80	1/2	80~300	219	326	210	140	70	25	139	16	80	130	110	160	M8	130	150	315	140	183	20	15	16.3	5	14
			165	130								200	M10	150	180	380	190	230	26	15	21.7	6	19		
100	1	80~300	244	377	260	170	90	5	179	-	100	165	130	200	M10	155	180	380	190	230	26	15	21.7	6	19
			244	377								260	170	90	5	179	-	100	165	130	200	M10	155	180	380
120	2	80~300	282	442	290	190	100	-	199	-	120	165	130	200	M10	185	215	450	220	266	30	18	21.7	6	19
			282	442								290	190	100	-	199	-	120	165	130	200	M10	185	215	450
135	3	80~300	306	487	324	214	110	16	219	16	135	165	130	200	M10	210	235	495	260	305	35	18	27.3	8	24
			215	180								250	M12	210	235	495	260	305	35	18	31.3	8	28		
155	5	80~300	325	525	392	253	140	2.5	263.5	-	155	215	180	250	M12	145	265	460	290	340	45	20	31.3	8	28
			215	180								250	M12	145	265	460	290	340	45	20	31.3	8	28		

2-STAGE WORM REDUCER (GEAR+WORM) SERIES

雙段蝸輪減速機 (齒輪 + 蝸輪) 系列

MODEL : VOFG

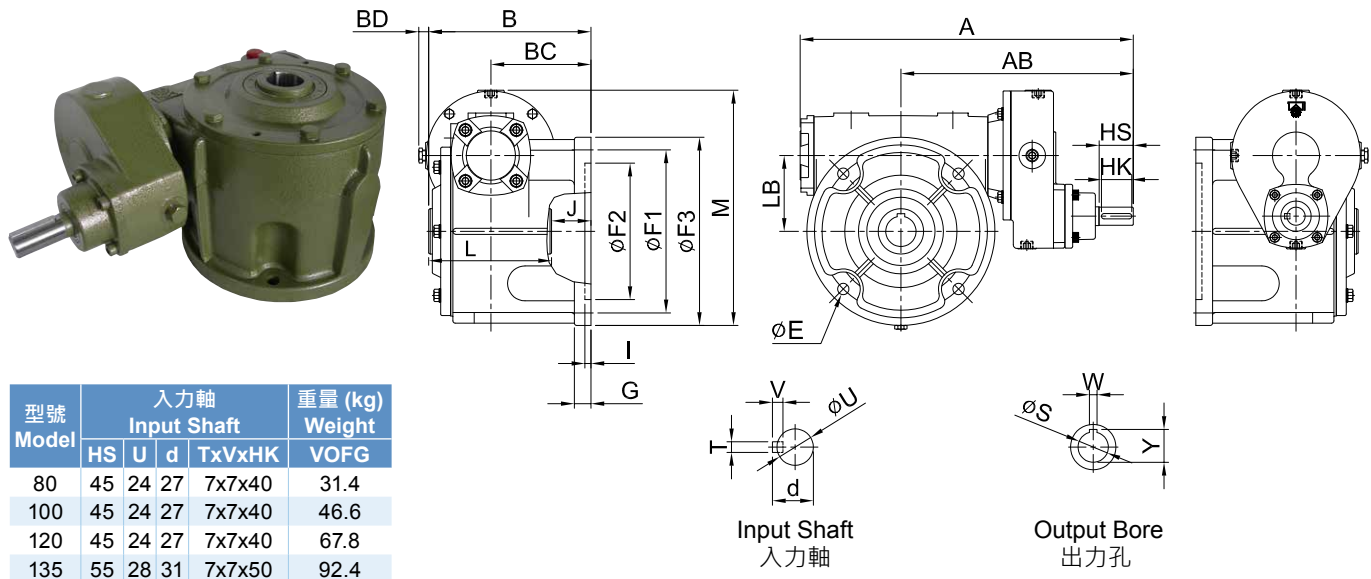

MODEL : VOFGM

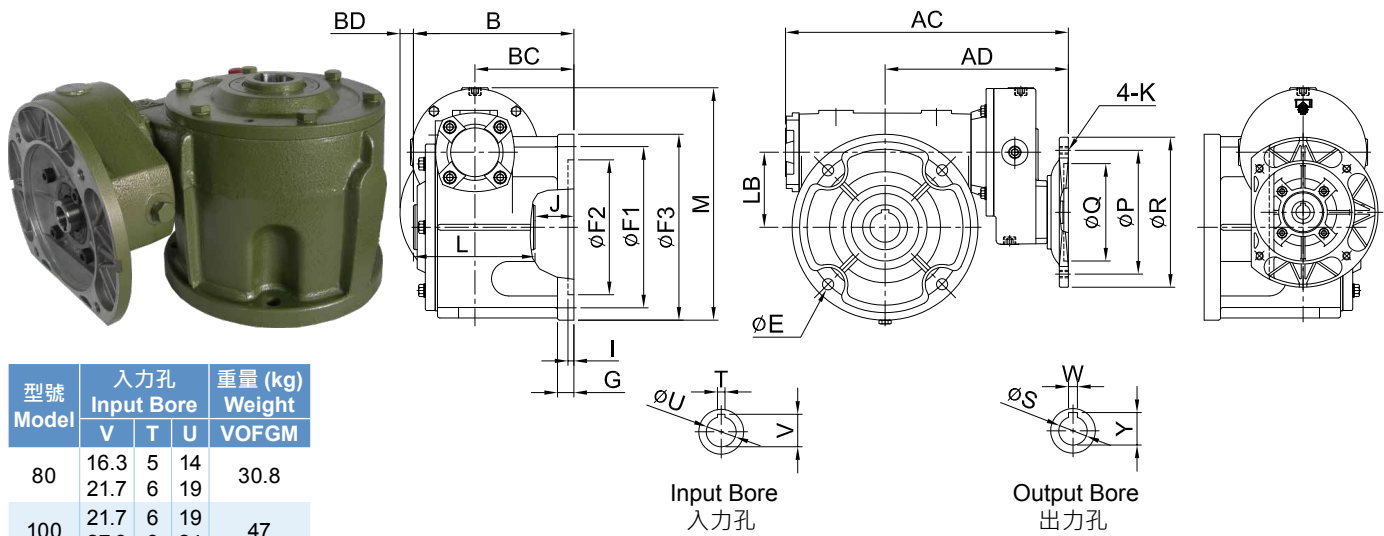

unit: mm

型號 Model	馬力 HP (4P)	減速比 Ratio	馬達盤 IEC Motor Flange									法蘭面 Flange							出力孔 Output Bore							
			A	AB	AC	AD	B	BC	BD	LB	M	P	Q	R	K	E	F1	F2	F3	J	G	I	W	Y	S	L
			80	100	120	135	80	100	120	135	130	165	165	165	165	4-15	300	260	330	30	20	8	10	10	12	15
80	1/2	80~300	389	282	326	219	180	107	22	80	266	130	110	160	M8	4-15	170	130	200	30	20	8	10	38.3	35	150
		80~160		327	220								165	130	200	M10										
100	1	80~300	439	306	377	244	214	132	18	100	310	165	130	200	M10	4-15	215	180	248	52	22	8	10	43.3	40	162
		80~160																								
120	2	80~300	509	344	447	282	234	145	11	120	371	165	130	200	M10	8-18	300	260	330	56	24	6	12	48.3	50	178
		80~200																								
135	3	80~300	582	401	487	306	247	155	33	135	415	165	130	200	M10	8-18	330	290	360	63	25	7	15	59.3	55	184
		80~200											215	180	250	M12										

■ 安裝方向 Installation Direction (VOFGM)

● 油面計
Oil Indicator

▼ 注油栓
Oil Plug

△ 排油栓
Oil Drain Plug

◆ 入力軸段可提供反向安裝。

◆ 正常的使用方向可以使減速機保持較高的壽命。
The life time of gear reducer can be prolonged in proper direction.

◆ 安裝時請注意油面計、注油栓及排油栓的位置以便日後維護。
Please note the positions of oil gauge, oil filling plug and oil drain plug to facilitate the maintenance afterwards.

◆ 減速機使用方向特殊時，請與我們聯繫。
For special installation direction, please contact us.

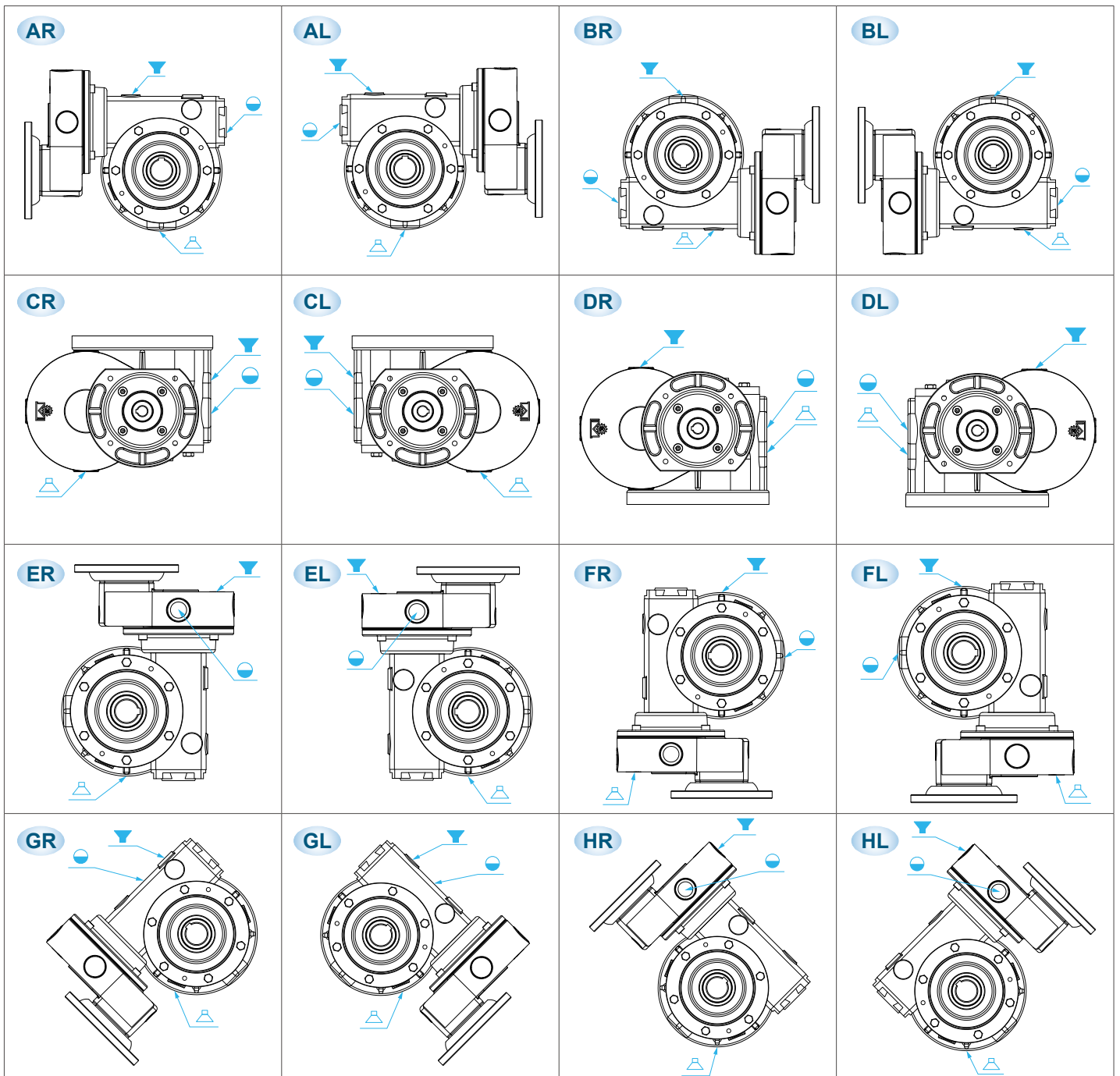

WORM REDUCER SERIES

蝸輪減速機系列

■ 蝸輪減速機零件對照表 Comparison Table of Parts

油封規格 Oil Seal

型號 Model	出力軸蓋 Output Shaft Cover	入力軸蓋 Input Shaft Cover	出力軸蓋 (VOW) Output Shaft Cover	出力軸蓋 (VOF) Output Shaft Cover	剎車盤 Brake Disc	無段盤	油壓盤 Oil Pressure Cover
	TC	SC	TC	TC	SC	SC	SC
40#	17X30X7	15X25X6	30X50X7				
50#	20X35X7	17X30X7	40X55X7		17X30X7	17X30X7	
60#	25X40X7	20X35X7	40X62X10		20X35X7	20X35X7	
70#	30X46X7	25X40X7	50X70X10	50X70X10	25X40X7	25X40X7	
80#	35X50X7	30X46X8	55X75X10	50X62X7	30X46X8	30X46X8	30X46X8
100#	40X62X10	35X50X7	70X90X12	60X90X10	35X50X7	35X50X7	45X62X8
120#	50X70X10	40X62X10	70X90X12	75X100X13	40X62X10	40X62X10	50X70X10
135#	60X80X12	45X62X8	80X100X12	80X100X12			45X62X6
155#	70X90X12	45X62X8	90X125X12				45X62X6
175#	75X100X13	50X70X10	120X150X14				50X70X10
200#	80X100X12	55X75X10	120X150X14				55X75X10
225#	85X110X13	60X80X10					60X80X10
250#	95X120X13	70X90X10					70X90X10
300#	100X130X13	80X100X13					
350#	120X150X14	90X110X13					

型號 Model	入力軸 Input Shaft						
	1/4 HP	1/2HP	1HP	2HP	3HP、5HP	7 1/2、10HP	15HP
50#	17x35x5	25x35x7					
60#	25x40x7	25x40x7					
70#		25x46x7	28x46x7				
80#		30x55x7	30x55x7	35x55x8			
100#			35x62x10	35x62x10	40x62x10		
120#				50x70x10	50x70x10		
135#					55x80x10	55x80x10	55x80x10
155#					55x80x10	55x80x10	55x80x10
175#						60x90x10	60x90x10

以上數值僅供參考，如有變更恕不另行通知。The above information is for reference only. No notices will be made for any changes.

■ 蝸輪減速機零件對照表 Comparison Table of Parts

軸承規格 Ball Bearing

型號 Model	入力軸 Input Shaft		出力軸 Output Shaft		
	標準 Standard	標準 Standard	VOW	VOF	VOW 角牙
40#	6202 x 2	6203 x 2	6007 x 2		30206 x 2
50#	6203 x 2	6204 x 2	6008 x 2		32008 x 2
60#	6204 x 2	6205 x 2	6008x 2		30208 x 2
70#	6205 x 2	6206 x 2	6010 x 2	6210 x 2	30210 x 2
80#	6206 x 2	6207 x 2	6011 x 2	6010 x 2	30211 x 2
100#	30207 x 2	6208 x 2	6214 x 2	6212 x 2	30214 x 2
120#	30308 x 2	6210 x 2	6214 x 2	6215 x 2	30214 x 2
135#	30309 x 2	6212 x 2	6216 x 2	6216 x 2	30216 x 2
155#	30309 x 2	6214 x 3	6218 x 2		
175#	30310 x 2	6215 x 3	6224 x 2		
200#	30311 x 2	6216 x 4	6224 x 2		
225#	30312 x 2	6217 x 4			
250#	30314 x 2	NJ219 x 2			
300#	30316 x 2	NJ220 x 2			
350#	30318 x 2	NJ224 x 2			

型號 Model	入力軸 Input Shaft						
	1/4 HP	1/2HP	1HP	2HP	3HP、5HP	7 1/2、10HP	15HP
50#	6203 x 2	6202 x2					
60#	6005 x1 6204 x1	6005 x1 6204 x1					
70#		6205 x2	320/28 x1 30205 x1				
80#		6206 x2	6206 x2	6206 x1 6007 x1			
100#			30207 x2	30207 x2	6008 x1 30206 x2		
120#				30210 x2	30210 x2		
135#					30211 x1 30309 x1	30211 x1 30309 x1	
155#					30211 x1 30309 x1	30211 x1 30309 x1	30211 x1 30309 x1
175#						30212 x1 30310 x1	30212 x1 30310 x1

以上數值僅供參考，如有變更恕不另行通知。The above information is for reference only. No notices will be made for any changes.

WORM REDUCER SERIES

蝸輪減速機系列

馬力、扭矩對照表 (單段) Horsepower and Torque Collate (1-Stage)

輸入轉速 Input R.P.M.		1800 RPM				1500 RPM				1200 RPM				900 RPM				600 RPM				300 RPM			
Model	Ratio	P ₁	P ₀	T ₀	F ₀	P ₁	P ₀	T ₀	F ₀	P ₁	P ₀	T ₀	F ₀	P ₁	P ₀	T ₀	F ₀	P ₁	P ₀	T ₀	F ₀	P ₁	P ₀	T ₀	F ₀
40	1/10	0.83	0.65	2.6	70	0.77	0.6	2.8	70	0.67	0.51	3.1	70	0.56	0.43	3.4	70	0.43	0.32	3.8	70	0.23	0.16	3.8	70
	1/15	0.41	0.28	2.3	70	0.37	0.25	2.5	70	0.33	0.20	2.8	70	0.27	0.17	3.2	70	0.2	0.11	3.5	70	0.11	0.04	3.8	70
	1/20	0.39	0.27	2.1	70	0.35	0.24	2.3	70	0.31	0.21	2.5	70	0.27	0.17	2.8	70	0.2	0.12	3.1	70	0.12	0.08	3.7	70
	1/30	0.43	0.28	3.3	70	0.4	0.25	3.5	70	0.34	0.21	3.8	70	0.27	0.16	3.8	70	0.2	0.11	3.8	70	0.09	0.04	3.8	70
	1/40	0.27	0.15	2.5	70	0.24	0.15	2.6	70	0.21	0.12	2.8	70	0.19	0.11	3.1	70	0.15	0.07	3.4	70	0.08	0.04	3.8	70
	1/50	0.25	0.15	2.8	70	0.23	0.12	3.0	70	0.2	0.11	3.2	70	0.17	0.11	3.5	70	0.12	0.05	3.8	70	0.07	0.03	3.8	70
	1/60	0.20	0.11	2.4	70	0.19	0.09	2.6	70	0.16	0.08	2.7	70	0.15	0.07	3.0	70	0.11	0.04	3.2	70	0.07	0.03	3.8	70
50	1/10	1.44	1.15	4.59	100	1.31	1.03	4.94	107	1.16	0.90	5.40	115	0.89	0.68	5.43	120	0.60	0.45	5.43	140	0.31	0.23	5.43	200
	1/15	1.07	0.81	4.89	115	0.97	0.73	5.22	120	0.82	0.60	5.43	130	0.63	0.45	5.43	140	0.43	0.30	5.43	160	0.22	0.15	5.43	200
	1/20	0.65	0.48	3.85	130	0.58	0.43	4.13	140	0.51	0.37	4.48	155	0.43	0.31	4.94	170	0.32	0.22	5.43	200	0.17	0.12	5.43	200
	1/30	0.68	0.45	5.43	150	0.58	0.37	5.43	170	0.48	0.30	5.43	180	0.37	0.22	5.43	200	0.25	0.15	5.43	200	0.14	0.07	5.43	200
	1/40	0.44	0.28	4.50	170	0.40	0.25	4.80	180	0.35	0.21	5.16	200	0.28	0.17	5.43	200	0.20	0.11	5.43	200	0.10	0.05	5.43	200
	1/50	0.39	0.23	4.55	200	0.35	0.20	4.94	200	0.31	0.17	5.29	200	0.24	0.13	5.43	200	0.17	0.09	5.43	200	0.09	0.04	5.43	200
	1/60	0.31	0.18	4.35	200	0.28	0.16	4.60	200	0.24	0.13	4.87	200	0.21	0.11	5.43	200	0.15	0.07	5.43	200	0.08	0.03	5.43	200
60	1/10	2.32	1.87	7.44	98	2.08	1.66	7.95	104	1.88	1.47	8.80	110	1.57	1.21	9.68	121	1.23	0.93	11.1	140	0.66	0.48	11.6	200
	1/15	1.72	1.32	7.91	116	1.55	1.18	8.46	123	1.36	1.01	9.07	133	1.17	0.85	10.2	145	0.90	0.64	11.5	167	0.48	0.32	11.6	200
	1/20	1.21	0.89	7.15	138	1.10	0.80	7.66	146	0.98	0.69	8.31	157	0.83	0.57	9.16	172	0.65	0.43	10.4	200	0.38	0.24	11.6	200
	1/30	1.14	0.78	9.31	151	1.05	0.70	10.0	159	0.92	0.59	10.6	172	0.78	0.48	11.6	189	0.54	0.32	11.6	200	0.29	0.16	11.6	200
	1/40	0.82	0.52	8.27	178	0.75	0.46	8.83	189	0.67	0.39	9.49	200	0.58	0.32	10.4	200	0.45	0.24	11.6	200	0.25	0.12	11.6	200
	1/50	0.77	0.49	9.70	200	0.70	0.43	10.2	200	0.62	0.37	11.0	200	0.40	0.23	9.22	200	0.31	0.17	10.3	200	0.19	0.09	11.6	200
	1/60	0.64	0.38	9.20	200	0.58	0.35	9.7	200	0.51	0.29	10.4	200	0.43	0.24	11.3	200	0.25	0.13	9.52	200	0.14	0.07	11.2	200
70	1/10	3.48	2.82	11.2	128	3.11	2.50	11.9	136	2.77	2.20	13.1	145	2.33	1.81	14.4	159	1.85	1.41	16.9	180	1.20	0.88	21.1	228
	1/15	2.53	1.96	11.7	153	2.29	1.76	12.6	161	2.02	1.52	13.6	174	1.73	1.28	15.2	190	1.34	0.96	17.3	218	0.87	0.59	21.4	277
	1/20	1.93	1.47	11.7	178	1.75	1.31	12.5	188	1.55	1.14	13.6	202	1.31	0.94	15.0	222	1.02	0.71	17.1	255	0.65	0.43	20.6	300
	1/30	1.69	1.16	13.8	198	1.55	1.05	15.0	208	1.36	0.89	16.1	225	1.18	0.74	17.7	247	0.92	0.56	20.1	284	0.59	0.33	23.8	300
	1/40	1.24	0.82	13.1	233	1.13	0.73	14.0	247	1.01	0.63	15.0	266	0.86	0.51	16.5	293	0.67	0.39	18.6	300	0.43	0.23	21.9	300
	1/50	1.12	0.72	14.3	266	1.03	0.64	15.2	282	0.91	0.55	16.3	300	0.77	0.45	17.8	300	0.60	0.33	19.7	300	0.39	0.19	23.2	300
	1/60	0.94	0.58	13.9	289	0.86	0.51	14.6	300	0.76	0.43	15.6	300	0.65	0.36	17.0	300	0.50	0.26	18.6	300	0.32	0.15	22.0	300
80	1/10	4.93	4.01	15.9	180	4.43	3.48	17.0	191	2.89	3.12	18.6	204	3.30	2.59	20.6	224	2.63	2.02	24.1	254	1.70	1.26	30.1	321
	1/15	3.57	2.79	16.7	215	3.21	2.49	17.8	228	2.83	2.17	19.4	244	2.44	1.81	21.7	267	1.90	1.38	24.7	306	1.24	0.85	30.7	288
	1/20	2.53	1.90	15.1	253	2.30	1.71	16.3	267	2.04	1.49	17.8	287	1.73	1.22	19.5	316	1.37	0.93	22.4	362	0.89	0.57	27.2	400
	1/30	2.38	1.66	19.8	277	2.15	1.47	21.1	294	1.90	1.28	22.9	316	1.65	1.06	25.3	345	1.31	0.80	28.7	398	0.84	0.47	34.0	400
	1/40	1.70	1.10	17.5	326	1.54	0.98	18.7	347	1.38	0.55	20.4	372	1.19	0.69	22.2	400	0.94	0.52	25.0	400	0.62	0.31	29.8	400
	1/50	1.57	1.01	20.1	364	1.43	0.90	21.6	385	1.28	0.77	23.1	400	1.09	0.63	25.1	400	0.85	0.47	28.0	400	0.55	0.28	33.0	400
	1/60	1.29	0.79	18.9	400	1.18	0.71	20.4	400	1.05	0.60	21.6	400	0.91	0.50	23.7	400	0.70	0.36	26.0	400	0.46	0.21	30.8	400
100	1/10	8.73	7.18	28.5	167	7.83	6.46	30.8	177	6.83	5.6	33.4	190	5.87	4.69	37.3	207	4.68	3.65	43.3	235	2.79	2.09	50	297
	1/15	6.33	5.02	29.9	204	5.66	4.43	31.7	217	5.09	3.94	35.3	230	4.33	3.29	39.3	251	3.38	2.48	44.5	289	1.99	1.39	50	365
	1/20	5.02	3.93	31.2	239	4.57	3.54	33.8	252	4.03	3.09	36.9	269	3.40	2.53	40.3	297	2.67	1.93	46.2	240	1.52	1.04	50	435
	1/30	4.20	3.00	35.8	265	3.81	2.66	38.2	281	3.35	2.30	41.1	302	2.89	1.92	46.0	330	2.23	1.39	50.0	382	1.20	0.69	50	500
	1/40	3.17	2.20	35.1	316	2.86	1.96	37.4	336	2.54	1.71	40.9	359	2.03	1.28	46.0	397	1.71	1.04	50.0	458	0.92	0.52	50	500
	1/50	2.39	1.59	31.8	364	2.17	1.42	24.0	386	1.93	1.24	37.0	415	1.66	1.01	40.2	458	1.29	0.75	44.7	500	0.79	0.41	50	500
	1/60	1.96	1.27	30.4	400	1.79	1.14	32.7	424	1.49	0.97	34.9	458	1.37	0.79	38.1	500	1.05	0.58	42.0	500	0.68	0.34	49.8	500
120	1/10	13.8	11.4	45.7	177	12.6	10.4	49.6	184	11.0	9.02	53.8	198	9.38	7.55	60.1	214	7.46	5.86	69.9	241	4.64	3.51	84.0	305
	1/15	10.0	8.05	48.0	218	9.02	7.15	51.2	231	8.08	6.32	56.5	244	6.83	5.26	62.8	267	5.39	4.01	71.9	305	3.30	2.34	84.0	386
	1/20	7.16	5.54	44.0	270	6.49	4.97	47.4	285	5.72	4.30	51.2	306	4.85	3.58	57.0	335	3.87	2.74	65.4	383	2.53	1.69	80.7	488
	1/30	6.66	4.82	57.5	285	6.00	4.28	61.3	302	5.31	3.70	77.3	325	4.55	3.09	73.0	354	3.65	2.34	83.9	408	1.97	1.17	84.0	531
	1/40	4.68	3.19	50.7	357	4.19	2.81	53.6	380	3.77	2.45	58.5	407	3.24	2.03	64.8	446	2.62	1.53	73.3	514	1.64	0.88	84.0	665
	1/50	3.93	2.74	54.5	404	3.54	2.43	58.0	429	3.15	2.12	63.4	459	2.69	1.72	68.7	508	2.09	1.28	76.5	588	1.24	0.70	84.0	700
	1/60	3.14	2.04	48.9	453	2.84	1.81	51.9	481	2.52	1.56	56.2	518	2.17	1.28	61.3	571	1.70	0.94	67.5	662	1.12	0.56	81.1	700
135	1/10	19.8	16.5	66.0	304	18.0	15.0	71.7	319	15.8	13.0	77.7	342	13.3	10.9	86.8	372	10.6	8.46	101	421	6.87	5.30	126	533
	1/15	14.7	11.9	71.4	362	13.1	10.6	76.1	384	11.8	9.38	84.0	407	9.95	7.82	93.3	445	7.83	5.96	106	510	5.11	3.73	133	644
	1/20	11.3	9.11	72.5	426	10.3	8.19	78.2	449	8.97	7.03	83.9	484	7.69	5.92	94.3	528	6.05	4.51	107	605	3.88	2.76	131	777
	1/30	9.68	7.21	86.0	468	8.71	6.40	91.7	496	7.70	5.53	99.1	533	6.58	4.62	110	583								

馬力、扭矩對照表 (單段)

Horsepower and Torque Collate (1-Stage)

輸入轉速 Input R.P.M.		1800 RPM				1500 RPM				1200 RPM				900 RPM				600 RPM				300 RPM			
Model	Ratio	P ₁	P ₀	T ₀	F ₀	P ₁	P ₀	T ₀	F ₀	P ₁	P ₀	T ₀	F ₀	P ₁	P ₀	T ₀	F ₀	P ₁	P ₀	T ₀	F ₀	P ₁	P ₀	T ₀	F ₀
155	1/10	32.9	27.3	105	1500	29.8	24.7	114	1500	26.4	21.7	125	1500	22.3	18.1	139	1500	17.8	14.3	165	1500	11.7	8.99	207	1500
	1/15	22.9	18.5	106	1500	20.5	16.5	114	1500	18.1	14.4	124	1500	15.4	12.0	139	1500	12.1	9.31	161	1500	8.96	5.84	202	1500
	1/20	14.9	11.8	94.5	1500	13.5	10.6	102	1500	11.9	9.29	110	1500	10.0	7.70	122	1500	8.01	5.94	141	1500	5.18	3.65	174	1500
	1/30	13.3	9.78	112	1500	12.1	8.82	122	1500	10.4	7.55	130	1500	9.08	6.32	146	1500	7.24	4.87	168	1500	4.77	2.92	202	1500
	1/40	9.32	6.67	106	1500	8.26	5.86	112	1500	7.40	5.11	122	1500	6.23	4.22	134	1500	5.02	3.19	152	1500	3.25	1.91	182	1500
	1/50	7.13	4.97	98.9	1500	6.42	4.40	105	1500	5.76	3.84	114	1500	4.89	3.17	126	1500	3.90	2.37	141	1500	2.53	1.41	168	1500
	1/60	5.85	3.99	95.3	1500	5.37	3.57	102	1500	4.72	3.05	109	1500	3.94	2.48	118	1500	3.20	1.87	133	1500	2.10	1.12	160	1500
175	1/10	46.8	39.1	150	1770	42.5	35.4	163	1800	37.7	31.3	180	1800	31.7	26.0	200	1800	25.2	20.4	235	1800	16.6	12.9	297	1800
	1/15	33.0	26.7	154	1800	29.6	23.9	165	1800	25.9	20.8	180	1800	22.1	17.5	202	1800	17.3	13.4	233	1800	11.4	8.44	292	1800
	1/20	22.8	18.2	141	1800	20.4	16.2	151	1800	18.0	14.2	165	1800	15.2	11.7	182	1800	12.1	9.15	212	1800	7.87	5.62	261	1800
	1/30	19.0	14.1	163	1800	17.2	12.7	176	1800	15.0	11.0	190	1800	12.9	9.20	212	1800	10.2	7.04	243	1800	8.73	4.23	293	1800
	1/40	13.2	9.60	149	1800	11.9	8.58	159	1800	10.4	7.36	171	1800	8.96	6.12	190	1800	7.10	4.65	216	1800	4.69	2.80	261	1800
	1/50	9.78	6.81	135	1800	8.74	6.03	144	1800	7.98	5.37	160	1800	6.64	4.32	171	1800	5.28	3.25	194	1800	3.46	1.94	231	1800
	1/60	8.23	5.74	132	1800	7.74	5.31	147	1800	6.62	4.41	152	1800	5.56	3.60	166	1800	4.45	2.70	187	1800	2.90	1.62	224	1800
200	1/10	52.6	44.0	181	1750	47.7	39.9	196	1840	41.8	34.8	215	1950	35.6	29.3	241	1800	28.0	22.8	281	2200	18.5	14.4	366	2200
	1/15	39.5	32.1	198	1990	35.4	28.7	212	2090	30.9	25.0	231	2200	26.3	21.0	259	2120	20.6	16.1	298	2200	13.6	10.0	373	2200
	1/20	30.2	24.3	193	2200	27.0	21.6	206	2200	23.8	18.9	226	2200	20.1	15.7	250	2200	15.9	12.2	291	2200	10.3	7.48	357	2200
	1/30	25.1	18.8	232	2200	22.6	16.8	249	2200	19.8	14.6	270	2200	16.9	12.1	300	2200	13.3	9.32	345	2200	8.78	5.60	414	2200
	1/40	18.2	13.3	213	2200	16.5	12.0	230	2200	14.3	10.3	247	2200	12.3	8.62	274	2200	9.56	6.43	307	2200	6.44	3.94	376	2200
	1/50	13.8	9.84	195	2200	12.3	8.68	207	2200	11.2	7.76	231	2200	9.29	6.21	247	2200	7.33	4.69	280	2200	4.82	2.80	334	2200
	1/60	11.5	8.01	188	2200	10.3	7.11	200	2200	9.64	6.49	228	2200	7.76	5.05	237	2200	6.12	3.77	265	2200	4.03	2.26	318	2200
225	1/10	71.2	60.2	239	2150	64.6	54.5	260	2260	56.7	47.7	284	2400	48.1	40.1	319	2500	37.9	31.2	372	2500	24.9	19.8	473	2500
	1/15	56.8	46.9	280	2410	50.9	41.9	300	2500	44.4	36.4	326	2500	37.8	30.6	365	2500	29.5	23.5	422	2500	19.3	14.7	527	2500
	1/20	43.4	35.2	280	2500	38.7	31.2	298	2500	34.1	27.4	326	2500	28.8	22.8	363	2500	22.7	17.6	421	2500	14.7	10.8	518	2500
	1/30	37.3	28.7	342	2500	33.5	25.6	367	2500	29.3	22.3	399	2500	24.9	18.5	442	2500	19.6	14.2	508	2500	12.7	8.54	611	2500
	1/40	25.9	19.3	307	2500	23.6	17.4	333	2500	20.4	14.9	357	2500	17.6	12.5	399	2500	13.6	9.36	447	2500	9.09	5.72	546	2500
	1/50	19.4	14.2	282	2500	17.2	12.5	299	2500	15.6	11.1	334	2500	12.9	8.96	356	2500	10.1	6.77	404	2500	6.65	4.04	482	2500
	1/60	16.0	11.3	262	2500	14.2	10.0	278	2500	13.2	9.19	318	2500	10.6	7.15	330	2500	8.37	5.35	370	2500	5.51	3.20	443	2500
250	1/10	96.6	81.3	323	2700	88.3	74.2	354	2700	78.4	65.7	392	2700	65.5	54.7	435	2700	51.8	42.6	508	2700	34.2	27.1	648	2700
	1/15	72.3	59.3	354	2700	66.4	54.3	389	2700	57.9	47.2	423	2700	49.0	39.7	474	2700	38.3	30.3	544	2700	25.3	19.1	689	2700
	1/20	55.3	45.0	367	2700	49.2	39.9	391	2700	43.3	35.0	428	2700	36.4	29.0	473	2700	28.7	22.4	549	2700	18.6	13.8	678	2700
	1/30	47.2	35.8	427	2700	42.2	31.9	457	2700	37.1	27.9	499	2700	31.0	23.0	551	2700	24.7	17.6	633	2700	16.3	10.8	774	2700
	1/40	32.9	24.6	401	2700	29.8	22.2	435	2700	25.9	19.1	468	2700	22.8	16.4	537	2700	17.2	11.9	587	2700	11.4	7.30	715	2700
	1/50	23.7	17.3	359	2700	21.2	15.4	383	2700	18.7	13.5	418	2700	15.8	11.0	458	2700	12.2	8.23	511	2700	8.12	4.97	617	2700
	1/60	20.2	14.6	350	2700	18.0	12.9	371	2700	16.8	11.9	426	2700	13.4	9.21	439	2700	10.5	6.88	493	2700	6.91	4.13	591	2700
300	1/10	146	123	516	2590	133	111	563	2710	120	100	631	2860	101	84	704	3090	78	65	814	3460	52	42	1056	3800
	1/15	115	96	564	2910	105	87.2	616	3040	92	76	679	3210	78	64	757	3480	61	49	874	3800	40	31	1106	3800
	1/20	86	70	573	3150	79	65	631	3280	68	56	680	3500	58	47	759	3790	45	36	876	3800	30	22	1100	3800
	1/30	69	54	658	3560	62	48	706	3800	54	42	765	3800	45	35	848	3800	36	27	976	3800	23	16	1196	3800
	1/40	53	40	665	3800	47	35	710	3800	34	25	849	3800	28	19	979	3800	28	19	979	3800	18	12	1186	3800
	1/50	40	30	612	3800	36	27	659	3800	32	23	713	3800	28	20	828	3800	21	14	888	3800	14	9	1074	3800
	1/60	32	23	571	3800	28	21	608	3800	25	18	660	3800	21	15	729	3800	16	11	811	3800	11	6	980	3800
350	1/10					185	156	788	3260	165	139	876	3430	141	118	993	3680	110	92	1161	4080	73	59	1493	4890
	1/15					153	127	926	3680	138	114	1044	3850	115	94	1152	4170	90	73	1332	4650	59	46	1706	5100
	1/20	140	115	933	3900	129	106	1030	4000	111	91	1111	4320	95	77	1257	4640	74	59	1441	5100	48	37	1798	5100
	1/30					89	69	1043	4870	78	60	1133	5100	66	50	1263	5100	52	38	1461	5100	34	24	1792	5100
	1/40	79	59	991	5100	70	53	1061	5100	62	47	1171	5100	52	39	1297	5100	41	29	1475	5100	27	18	1782	5100
	1/50	62	46	926	5100	56	42	999	5100	49	36	1081	5100	41	30	1197	5100	44	31	1357	5100	29	19	1647	5100
	1/60	48	36	872	5100	43	32	933	5100	38	28	1011	5100	32	23	1115	5100	25	17	1249	5100	16	10	1512	5100

P₁ = 輸入軸馬力 (HP) Horsepower of Input Shaft T₀ = 輸出軸扭矩 (kgf-m) Torque of Output Shaft 以上數值僅供參考 The above information is for reference only.
 P₀ = 輸出軸馬力 (HP) Horsepower of Output Shaft F₀ = 懸垂荷重 (kgf) Loading

WORM REDUCER SERIES

蝸輪減速機系列

馬力、扭矩對照表 (蝸輪 + 蝸輪) Horsepower and Torque Collate (Worm+Worm)

輸入轉速 Input R.P.M.		1800 RPM				1500 RPM				1200 RPM				900 RPM			
Model	Ratio	P ₁	P ₀	T ₀	F ₀	P ₁	P ₀	T ₀	F ₀	P ₁	P ₀	T ₀	F ₀	P ₁	P ₀	T ₀	F ₀
32 / 60	1/200	0.29	0.14	11.6	200	0.25	0.12	11.6	200	0.19	0.09	11.6	200	0.16	0.07	11.6	200
	1/300	0.20	0.09	11.6	200	0.18	0.08	11.6	200	0.14	0.06	11.6	200	0.12	0.05	11.6	200
	1/400	0.16	0.07	11.6	200	0.14	0.06	11.6	200	0.12	0.05	11.6	200	0.10	0.04	11.6	200
	1/500	0.16	0.06	11.6	200	0.14	0.05	11.6	200	0.11	0.04	11.6	200	0.09	0.03	11.6	200
	1/600	0.13	0.05	11.6	200	0.11	0.04	11.6	200	0.09	0.03	11.6	200	0.06	0.02	11.6	200
	1/800	0.11	0.04	11.6	200	0.09	0.03	11.6	200	0.06	0.02	11.6	200	0.03	0.01	11.6	200
	1/900	0.10	0.03	11.6	200	0.09	0.03	11.6	200	0.06	0.02	11.6	200	0.03	0.01	11.6	200
40 / 70	1/200	0.57	0.30	23.8	300	0.49	0.25	24.7	300	0.40	0.20	25.0	300	0.32	0.16	25.0	300
	1/300	0.42	0.21	25.0	300	0.35	0.17	25.0	300	0.29	0.14	25.0	300	0.22	0.10	25.0	300
	1/400	0.34	0.16	25.0	300	0.29	0.13	25.0	300	0.23	0.10	25.0	300	0.19	0.08	25.0	300
	1/500	0.28	0.12	25.0	300	0.25	0.10	25.0	300	0.20	0.08	25.0	300	0.16	0.06	25.0	300
	1/600	0.24	0.10	25.0	300	0.22	0.09	25.0	300	0.18	0.07	25.0	300	0.14	0.05	25.0	300
	1/800	0.21	0.08	25.0	300	0.16	0.06	25.0	300	0.14	0.05	25.0	300	0.12	0.04	25.0	300
	1/900	0.21	0.07	25.0	300	0.19	0.06	25.0	300	0.16	0.05	25.0	300	0.10	0.03	25.0	300
50 / 80	1/200	0.68	0.35	28.2	400	0.66	0.33	31.7	400	0.57	0.28	33.7	400	0.46	0.22	35.0	400
	1/300	0.59	0.28	33.7	400	0.52	0.24	35.0	400	0.42	0.19	35.0	400	0.32	0.14	35.0	400
	1/400	0.52	0.22	35.0	400	0.43	0.18	35.0	400	0.35	0.14	35.0	400	0.29	0.11	35.0	400
	1/500	0.43	0.17	35.0	400	0.37	0.14	35.0	400	0.33	0.12	35.0	400	0.25	0.09	35.0	400
	1/600	0.35	0.14	35.0	400	0.30	0.12	35.0	400	0.27	0.10	35.0	400	0.20	0.07	35.0	400
	1/800	0.32	0.11	35.0	400	0.28	0.09	35.0	400	0.21	0.07	35.0	400	0.16	0.05	35.0	400
	1/900	0.29	0.10	35.0	400	0.24	0.08	35.0	400	0.18	0.06	35.0	400	0.16	0.05	35.0	400
60 / 100	1/200	1.13	0.63	50.0	450	0.96	0.52	50.0	450	0.79	0.42	50.0	450	0.59	0.31	50.0	450
	1/300	0.75	0.42	50.0	450	0.65	0.35	50.0	450	0.56	0.28	50.0	450	0.43	0.21	50.0	450
	1/400	0.62	0.31	50.0	450	0.53	0.26	50.0	450	0.44	0.21	50.0	450	0.35	0.16	50.0	450
	1/500	0.53	0.25	50.0	450	0.45	0.21	50.0	450	0.38	0.17	50.0	450	0.28	0.12	50.0	450
	1/600	0.46	0.21	50.0	450	0.39	0.17	50.0	450	0.34	0.14	50.0	450	0.25	0.10	50.0	450
	1/800	0.39	0.16	50.0	450	0.32	0.13	50.0	450	0.26	0.10	50.0	450	0.22	0.08	50.0	450
	1/900	0.38	0.14	50.0	450	0.34	0.12	50.0	450	0.28	0.09	50.0	450	0.21	0.07	50.0	450
70 / 120	1/200	1.94	1.05	84.0	520	1.66	0.88	84.0	520	1.37	0.70	84.0	520	1.06	0.53	84.0	520
	1/300	1.40	0.70	84.0	520	1.20	0.58	84.0	520	1.00	0.47	84.0	520	0.76	0.35	84.0	520
	1/400	1.10	0.53	84.0	520	0.93	0.44	84.0	520	0.76	0.35	84.0	520	0.59	0.26	84.0	520
	1/500	0.97	0.42	84.0	520	0.83	0.35	84.0	520	0.70	0.28	84.0	520	0.53	0.21	84.0	520
	1/600	0.81	0.35	84.0	520	0.69	0.29	84.0	520	0.57	0.23	84.0	520	0.44	0.17	84.0	520
	1/800	0.63	0.26	84.0	520	0.56	0.22	84.0	520	0.44	0.17	84.0	520	0.36	0.13	84.0	520
	1/900	0.62	0.23	84.0	520	0.52	0.19	84.0	520	0.44	0.15	84.0	520	0.37	0.12	84.0	520
80 / 135	1/200	2.98	1.73	140	810	2.52	1.44	140	810	2.05	1.15	140	810	1.58	0.87	140	810
	1/300	2.09	1.15	140	810	1.77	0.96	140	810	1.48	0.77	140	810	1.16	0.58	140	810
	1/400	1.64	0.87	140	810	1.41	0.72	140	810	1.16	0.58	140	810	0.89	0.43	140	810
	1/500	1.40	0.69	140	810	1.20	0.58	140	810	0.97	0.46	140	810	0.79	0.35	140	810
	1/600	1.20	0.58	140	810	1.06	0.48	140	810	0.84	0.38	140	810	0.67	0.29	140	810
	1/800	0.95	0.43	140	810	0.83	0.36	140	810	0.70	0.29	140	810	0.55	0.22	140	810
	1/900	1.10	0.38	140	810	0.96	0.32	140	810	0.81	0.26	140	810	0.66	0.20	140	810
100 / 155	1/200	4.25	2.41	192	1700	3.72	2.07	198	1700	3.25	1.76	210	1700	2.67	1.42	226	1700
	1/300	3.32	1.76	210	1700	2.95	1.25	218	1700	2.58	1.29	231	1700	2.10	1.01	242	1700
	1/400	2.71	1.41	225	1700	2.44	1.22	234	1700	2.06	1.01	242	1700	1.58	0.76	242	1700
	1/500	2.36	1.18	236	1700	2.06	1.01	242	1700	1.68	0.81	242	1700	1.32	0.61	242	1700
	1/600	2.19	1.01	242	1700	1.86	0.84	242	1700	1.55	0.67	242	1700	1.19	0.50	242	1700
	1/800	1.68	0.76	242	1700	1.46	0.43	242	1700	1.21	0.51	242	1700	0.95	0.38	242	1700
	1/900	2.23	0.67	242	1700	1.86	0.56	242	1700	1.50	0.45	242	1700	1.13	0.34	242	1700
120 / 175	1/200	5.66	3.40	271	2000	5.12	2.97	284	2000	4.35	2.48	296	2000	3.56	1.99	317	2000
	1/300	4.44	2.48	296	2000	3.94	2.16	309	2000	3.43	1.83	327	2000	2.76	1.44	345	2000
	1/400	3.73	2.00	318	2000	3.30	1.73	331	2000	2.80	1.44	345	2000	2.18	1.08	345	2000
	1/500	3.14	1.68	334	2000	2.73	1.44	345	2000	2.26	1.16	345	2000	1.75	0.87	345	2000
	1/600	2.91	1.44	345	2000	2.50	1.20	345	2000	2.05	0.96	345	2000	1.60	0.72	345	2000
	1/800	2.35	1.08	345	2000	2.01	0.90	345	2000	1.67	0.72	345	2000	1.31	0.45	345	2000
	1/900	3.20	0.96	345	2000	2.66	0.80	345	2000	2.13	0.64	345	2000	1.60	0.48	345	2000

P₁ = 輸入軸馬力 (HP) Horsepower of Input Shaft T₀ = 輸出軸扭矩 (kgf·m) Torque of Output Shaft 以上數值僅供參考 The above information is for reference only.
P₀ = 輸出軸馬力 (HP) Horsepower of Output Shaft F₀ = 懸垂荷重 (kgf) Loading

蝸輪減速機一般故障原因及改善方法

Solutions and Reasons for Worm Reducer General Faults

故障情形 Fault Description	故障原因 Reasons	解決方法 Solutions
減速機過熱 Over-Heating	<ul style="list-style-type: none"> ◆超負荷運轉 ◆潤滑油過少或過多 ◆潤滑油不良或不適當 ◆油封過度磨擦 ◆出力軸與傳動裝置連接不當 ◆Insufficient or excess lubricant oil. ◆Inferior or improper lubricant oil. ◆Oil seal is over-rubbed. ◆Improper connection between driving shaft and the transmitting device. 	<ul style="list-style-type: none"> ◆調整至適當負荷 ◆依指示加入適量潤滑油 ◆油排出後加入適量潤滑油 ◆在油封處滴數滴潤滑油 ◆調整至適當位置 ◆Adjust to proper loading. ◆Fill in adequate lubricant oil as indication. ◆Fill in proper lubricant oil after draining out oil. ◆Drop lubricant at oil seal. ◆Adjust to proper position.
減速機雜音 Noise	<ul style="list-style-type: none"> ◆蝸輪、蝸桿嚙合不良 ◆軸承損傷或間隙過大 ◆潤滑油不足 ◆異物侵入 ◆Poor fit between worm heel and worm shaft. ◆Bearing damaged or clearance too large. ◆Insufficient lubricant oil. ◆Invaded by foreign objects. 	<ul style="list-style-type: none"> ◆修整齒接觸面 (請與本公司聯絡) ◆更換軸承 ◆依指示加入適量潤滑油 ◆去除異物並更換潤滑油 ◆Finish contact surfaces of gears (please contact with us). ◆Replace bearing. ◆Fill in adequate lubricant oil as indication. ◆Remove foreign objects and replace lubricant oil.
不正常振動 Abnormal Vibration	<ul style="list-style-type: none"> ◆傳動裝置固定不良 ◆蝸輪磨耗或損傷 ◆軸承磨耗或損傷 ◆螺栓鬆脫 ◆異物侵入 ◆Transmitting device is not fixed. ◆Worm wheel worn or damaged. ◆Bearing worn or damaged. ◆Bolt loosed. ◆Invaded by foreign objects. 	<ul style="list-style-type: none"> ◆將傳動裝置固定 ◆更換蝸輪 (請與本公司聯絡) ◆更換軸承 ◆鎖緊螺栓 ◆去除異物並更換潤滑油 ◆Fix transmitting device. ◆Replace worm wheel (please contact with us). ◆Replace bearing. ◆Tighten bolt. ◆Remove foreign objects and replace lubricant oil.
漏油 Oil Leakage	<ul style="list-style-type: none"> ◆油封損傷 ◆迫緊閉破損 ◆油量過多 ◆洩油栓鬆脫 ◆油鏡破損 ◆Oil seal damaged. ◆Gasket damaged. ◆Excess oil. ◆Oil drain plug loosed. ◆Oil gauge damaged. 	<ul style="list-style-type: none"> ◆更換油封 ◆更換迫緊 ◆依指示加入適量潤滑油 ◆鎖緊洩油栓 ◆更換油鏡 ◆Replace oil seal. ◆Replace gasket. ◆Fill in adequate lubricant oil as indication. ◆Tighten oil drain plug. ◆Replace oil gauge.
入力或出力軸不轉 Input or Output Shaft Doesn't Work	<ul style="list-style-type: none"> ◆蝸輪蝸桿過熱膨脹 ◆軸承損傷 ◆異物侵入 ◆蝸輪、蝸桿過度磨損 ◆Worm wheel and worm shaft expanded by overheating. ◆Bearing damaged. ◆Invaded by foreign objects. ◆Excess wear of worm wheel and worm shaft. 	<ul style="list-style-type: none"> ◆更換蝸輪或蝸桿 (請與本公司聯絡) ◆更換軸承 ◆去除異物並更換潤滑油 ◆更換蝸輪或蝸桿 (請與本公司聯絡) ◆Replace worm wheel or worm shaft (please contact with us). ◆Replace bearing ◆Remove foreign objects and replace lubricant oil. ◆Replace worm wheel or worm shaft (please contact with us).
蝸輪過度磨耗 Worm Wheel Over-Worn	<ul style="list-style-type: none"> ◆超負荷 ◆潤滑油不良或不適當 ◆潤滑油不足 ◆軸承磨損 ◆運轉溫度過高 ◆Overloading. ◆Inferior or improper lubricant oil. ◆Insufficient lubricant oil. ◆Bearing damaged. ◆Operating temperature too high. 	<ul style="list-style-type: none"> ◆調整至適當負荷 ◆更換適當潤滑油 ◆依指示加入適量潤滑油 ◆更換軸承 ◆改善通風環境 ◆Adjust to proper loading. ◆Replace proper lubricant oil. ◆Full in adequate lubricant oil as indication. ◆Replace bearing. ◆Improve ventilation conditions.

以上所列為一般故障原因，如有其它故障情形時，請與本公司連絡。

The above items are general fault descriptions. In case of other kinds of faults, please contact with us.