

電梯主機 Traction Machine

P15-6000 ^{CE}

■產品特性 Features

主軸靜荷重 Max. Static Load:	6,000 kg
最大升降行程 Allowable Travel (m):	40M
重量約 Weight:	490 kg
馬達額定電壓 Motor Rated Voltage:	208V / 360V
馬達額定電流 Motor Rated Current:	11kW = 39.7A / 22.9A ; 15kW = 53A / 30.6A
馬達絕緣等級 Motor INS. Class:	F
制動器電壓 Brake Voltage:	DC 110V
編碼器 Encoder:	ø30 中空型 (Central Through Type) 1024 P/R
編碼器電壓 Encoder Voltage:	DC 7-24V

■主槽輪向選擇 M/Sheave Direction

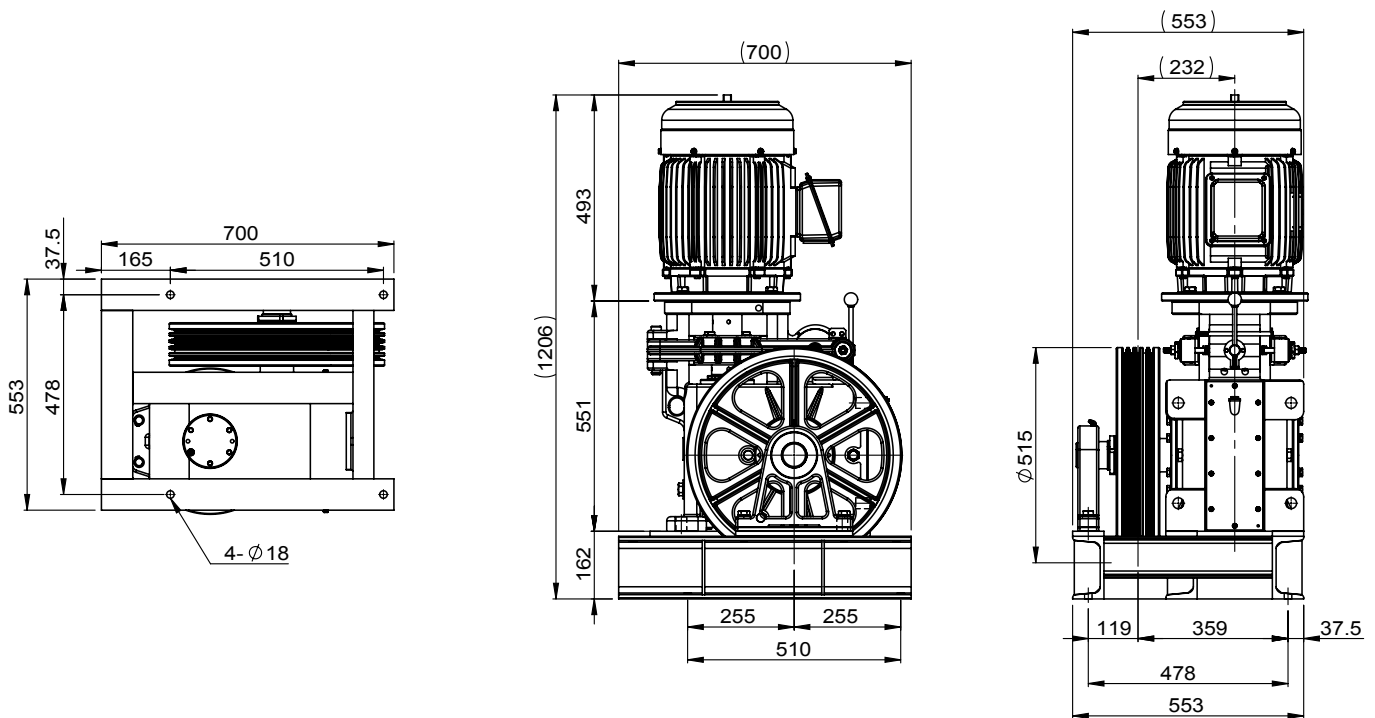
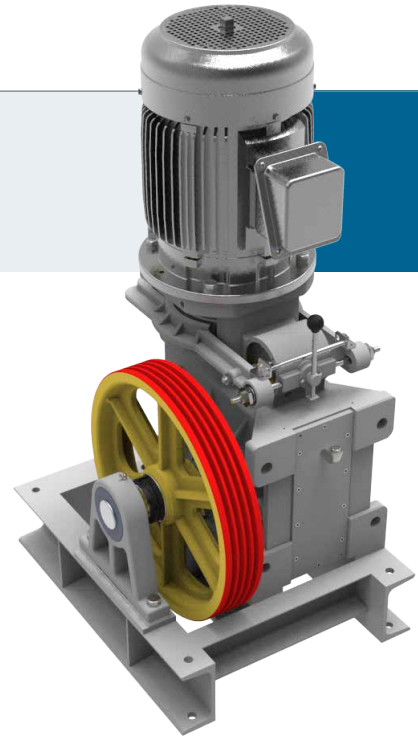
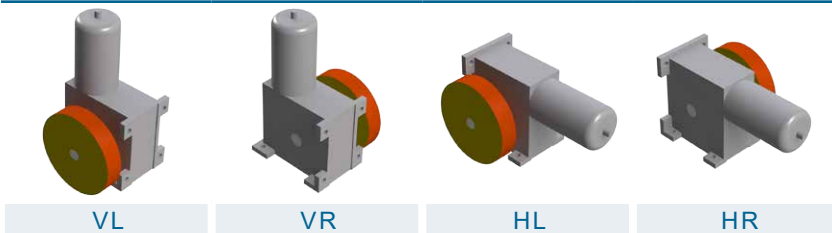

載重 Duty Load (kg)	速度 Speed (m/min)	掛比 Roping	減速比 Ratio	主槽輪 M / Sheave			馬達 Motor		
				節徑 Dia. (PCD) (mm)	鋼索 Rope (mm)	槽距 Pitch (mm)	功率 Power (kW)	極數 Poles (P)	頻率 Frequency (Hz)
900	90	1:1	2:48	Ø510	Ø10 X 4-5 / Ø12 X 4-5	16 / 19	15	4	45
1150	60	1:1	1:37	Ø510	Ø10 X 4-5 / Ø12 X 4-5	16 / 19	15	4	46
1500	60	2:1	2:37	Ø510	Ø10 X 4-5 / Ø12 X 4-5	16 / 19	15	4	46
2000	45	2:1	2:48	Ø510	Ø10 X 4-5 / Ø12 X 4-5	16 / 19	15	4	45
2000	30	2:1	1:37	Ø510	Ø10 X 4-5 / Ø12 X 4-5	16 / 19	11	4	46