

ST-DV series

RATIO : 1.2.3.4.5 (單段 1-Stage)

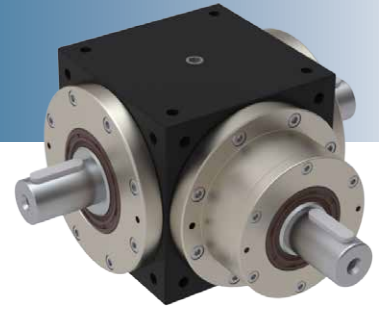

單入力軸心 - 雙出力軸心

Single Input Shaft - Double Output Shaft

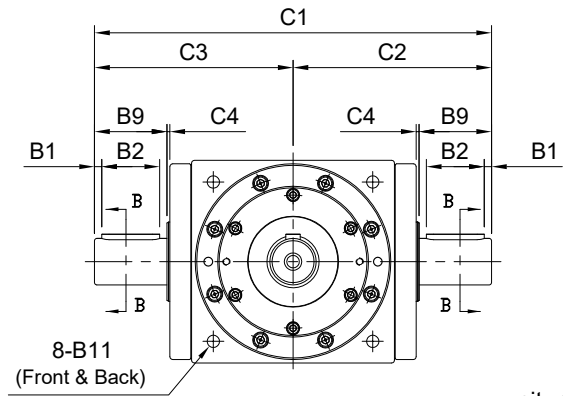
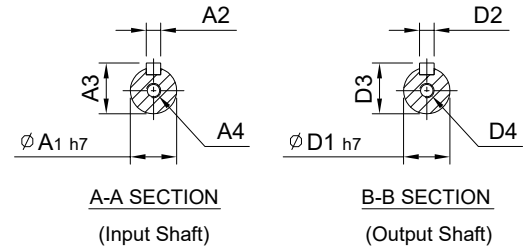
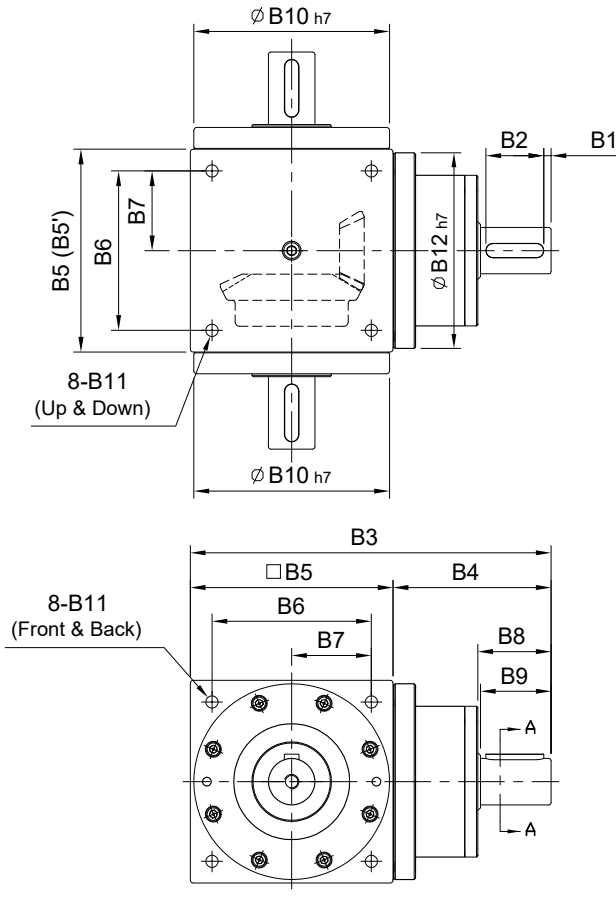

unit: mm

Model Code	65	65 (1:1)	75	90	110	140	170	210	240	280	
	A	A1	14	16	18	22	32	40	50	55	60
	A2	5	5	6	6	10	12	14	16	18	
	A3	16	18	20.5	24.5	35	43	53.5	59	64	
	A4	M5 x P0.8	M5 x P0.8	M8 x P1.25	M8 x P1.25	M10 x P1.5	M12 x P1.75	M12 x P1.75	M16 x P2.0	M16 x P2.0	
B	B1	2.5	2.5	5	5	5	5	5	5	5	
	B2	15	25	25	30	40	50	65	70	90	
	B3	127.5	143	168.5	207	250	300	375	430	505	
	B4	62.5	68	78.5	97	110	130	165	190	225	
	B5(B5')	65	75(74)	90	110	140	170(168)	210	240	280	
	B6	52	60	72	88	110	134	170	190	220	
	B7	26	30	36	44	55	67	85	95	110	
	B8	22	32	38	43	53.5	64	77	82	105	
	B9	20	30	35	40	50	60	75	80	100	
	B10	62	64	73	88	106	135	164	205	228	275
	B11	M5 x P0.8	M6 x P1.0	M6 x P1.0	M8 x P1.25	M10 x P1.5	M12 x P1.75	M16 x P2.0	M16 x P2.0	M16 x P2.0	M16 x P2.0
	B12	-	73	88	106	135	164	205	228	219	
C	C1	124	129	160	188	224	324	400	452	528	
	C2	62	64.5	80	94	112	137	200	226	264	
	C3	62	64.5	80	94	112	137	200	226	264	
	C4	2	2	2	2	2	2	2	2	3	
D	D1	14	16	18	22	32	40	50	55	60	
	D2	5	5	6	6	10	12	14	16	18	
	D3	16	18	20.5	24.5	35	43	53.5	59	64	
	D4	M5 x P0.8	M5 x P0.8	M5 x P0.8	M8 x P1.25	M10 x P1.5	M12 x P1.75	M12 x P1.75	M16 x P2.0	M16 x P2.0	M16 x P2.0
Weight ±3% (kg)		2.1	2.8	4.9	8.59	15.5	25	53	81.8		