

ST-DN series

RATIO : 1.2.3.4.5 (單段 1-Stage)



單入力軸心 - 單邊免鍵軸套

Single Input Shaft - Single Clamping

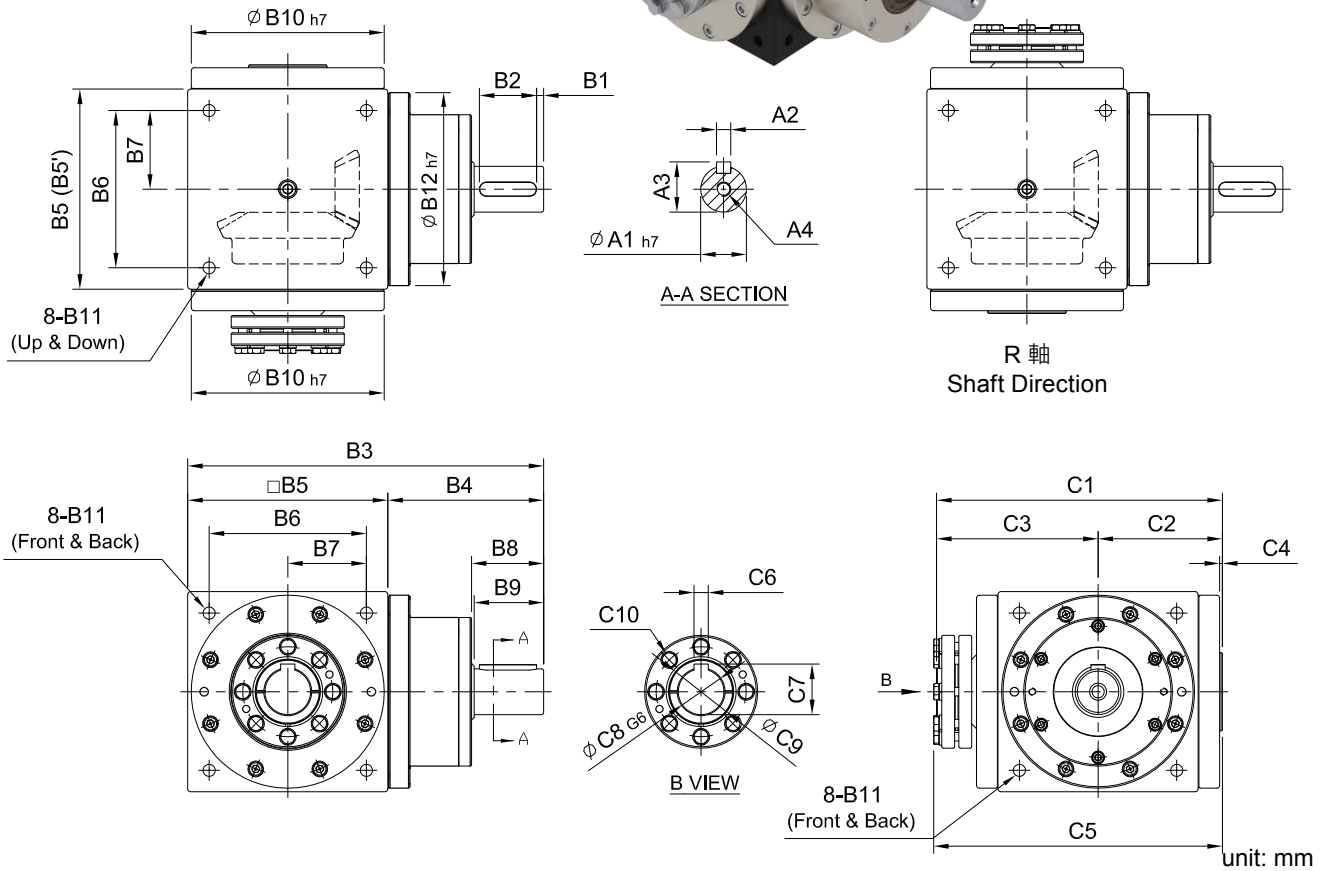

Model Code	65	65 (1:1)	75	90	110	140	170	210	240	280	
	A	A1	14	16	18	22	32	40	50	55	60
	A2	5	5	6	6	10	12	14	16	18	
	A3	16	18	20.5	24.5	35	43	53.5	59	64	
	A4	M5 x P0.8	M5 x P0.8	M8 x P1.25	M8 x P1.25	M10 x P1.5	M12 x P1.75	M12 x P1.75	M16 x P2.0	M16 x P2.0	
B	B1	2.5	2.5	5	5	5	5	5	5	5	
	B2	15	25	25	30	40	50	65	70	90	
	B3	127.5	143	168.5	207	250	300	375	430	505	
	B4	62.5	68	78.5	97	110	130	165	190	225	
	B5(B5')	65	75(74)	90	110	140	170(168)	210	240	280	
	B6	52	60	72	88	110	134	170	190	220	
	B7	26	30	36	44	55	67	85	95	110	
	B8	22	32	38	43	53.5	64	77	82	105	
	B9	20	30	35	40	50	60	75	80	100	
	B10	62	64	73	88	106	135	164	205	228	275
	B11	M5 x P0.8	M6 x P1.0	M6 x P1.0	M8 x P1.25	M10 x P1.5	M12 x P1.75	M16 x P2.0	M16 x P2.0	M16 x P2.0	
	B12	-	73	88	106	135	164	205	228	219	
C	C1	104	109	120	138	169	202	240	285	324	370
	C2	42	44.5	50	59	72	87	102	125	146	164
	C3	62	64.5	70	79	97	115	138	160	178	206
	C4	2	2	2	2	2	2	2	2	2	3
	C5	110	113	124	142	171	202	242	288	329	369.8
	C6	5	5	6	6	10	12	14	16	18	
	C7	16.3	16.3	20.8	24.8	35.3	43.3	53.8	59.3	64.4	
	C8	14	14	18	22	32	40	50	55	60	
	C9	22	22	28	34	44	52	65	73	83	
	C10	6-M6	6-M6	6-M6	8-M6	8-M6	8-M6	8-M6	8-M8	12-M8	12-M8
Weight $\pm 3\%$ (kg)	2.1	2.8	4.9	8.59	15.5	25	53	73.9			